

# General Catalogue

2020 — 2021

The world of heating and cooling  
is changing with Panasonic

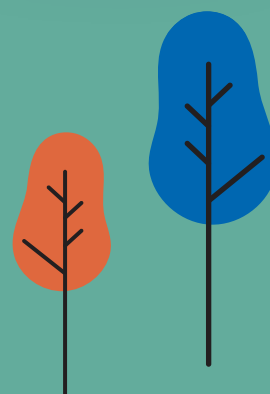

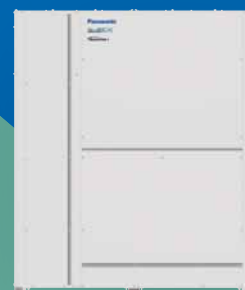

AQUAREA

P. 20



DOMESTIC

P. 70



COMMERCIAL

P. 96



VRF SYSTEMS

P. 176



HEAT PUMP CHILLERS

P. 218



REFRIGERATION

P. 252

# Panasonic: Eco & smart ideas for a sustainable lifestyle

A better life, a better world.

Panasonic is creating a safe and secure society with clean energy.



## Solar Power Generator

HIT solar cells achieve maximum output even on smaller roofs.

## Home AV

Panasonic offers a wide range of energy saving home equipment to fulfil a sustainable and comfortable lifestyle.

## Heat Pump

The Aquarea Heat Pump is part of a new generation of heating systems that use a renewable, free energy source: air, to heat or cool the home and to produce hot water.

## Fuel Cell

The Panasonic Fuel Cell is an energy-creating device, which generates electricity and heat at the same time with chemical reaction between hydrogen extracted from natural gas and oxygen.

## Solar Power Generator

Our mobility space can be connected to our HIT solar panels – with the help from our storage batteries.

## LED Lamps

Expertise gathered over years of research and development has enabled Panasonic to provide a renaissance in energy saving home LED lighting.

## Home Appliances

Panasonic is globally committed to develop products with minimised environmental impact. Panasonic delivers home appliances such as refrigerators and washing machines that incorporate the latest energy-efficient technology.

## Storage Battery

The battery stores the energy generated by a combination of solar power and fuel cells to ensure a constant supply of electricity on demand.

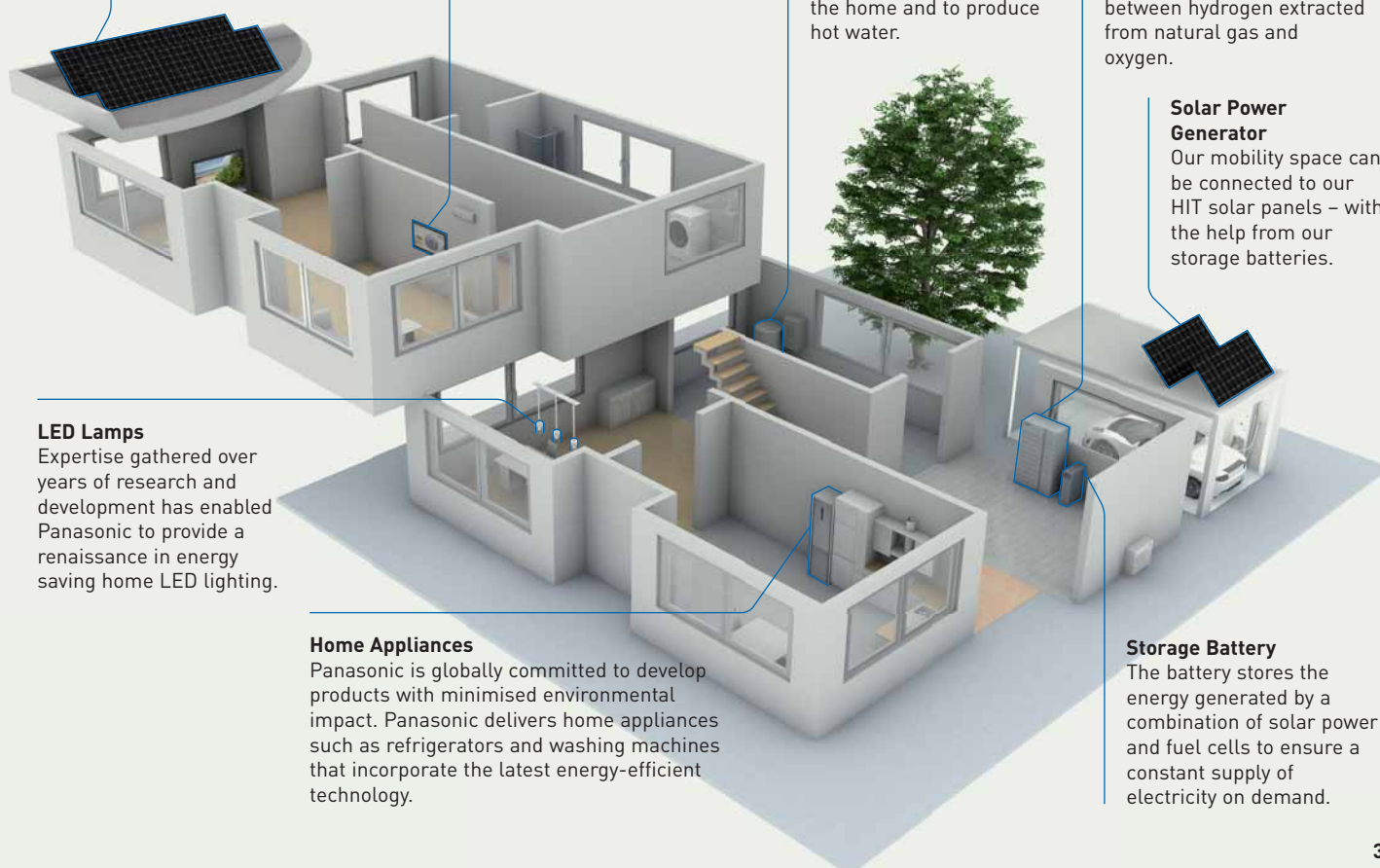

# A desire to create things of value

**"Recognising our responsibilities as industrialists, we will devote ourselves to the progress and development of society and the well-being of people through our business activities, thereby enhancing the quality of life throughout the world."**

Panasonic Corporation's Basic Management Objective, formulated in 1929 by the company's founder, Konosuke Matsushita.



Panasonic becomes one of the first Japanese air conditioner manufacturers in Europe.



Introduces world's first simultaneous 3-Pipe heating/cooling VRF System.



Starts production of absorption chillers.

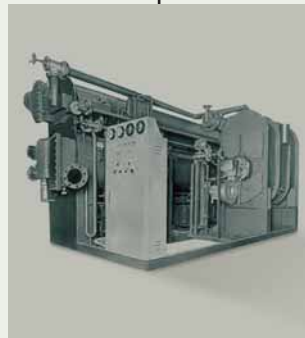

1958

1971

1973

1975

1985

1989



Panasonic launches the first highly efficient air-to-water heat pump in Japan.



First room air conditioner launched for domestic installation.



Introduces first GHP (gas heat pump) VRF air conditioner.

New Aquarea. Panasonic introduces Aquarea, an innovative new, low-energy system in Europe.



The first Hybrid System with VRF and GHP in Europe.



World's first air conditioner equipped with nanoe™



CO<sub>2</sub> condensing units in Europe. The ideal solution for supermarkets, shops and gas stations.



2008

2010

2012

2015

2016

2018

Looking ahead



Etherea new concept: high efficiency and high performances with a great design.



New VRF Systems ECOi EX with extraordinary energy saving performance.



New Panasonic GHP units. The gas-driven VRF Systems are ideal for projects where power restrictions apply.



Panasonic introduces a new Heat Pump Chiller series which is named as ECOi-W.

## A Globally Trusted Air Conditioning Brand

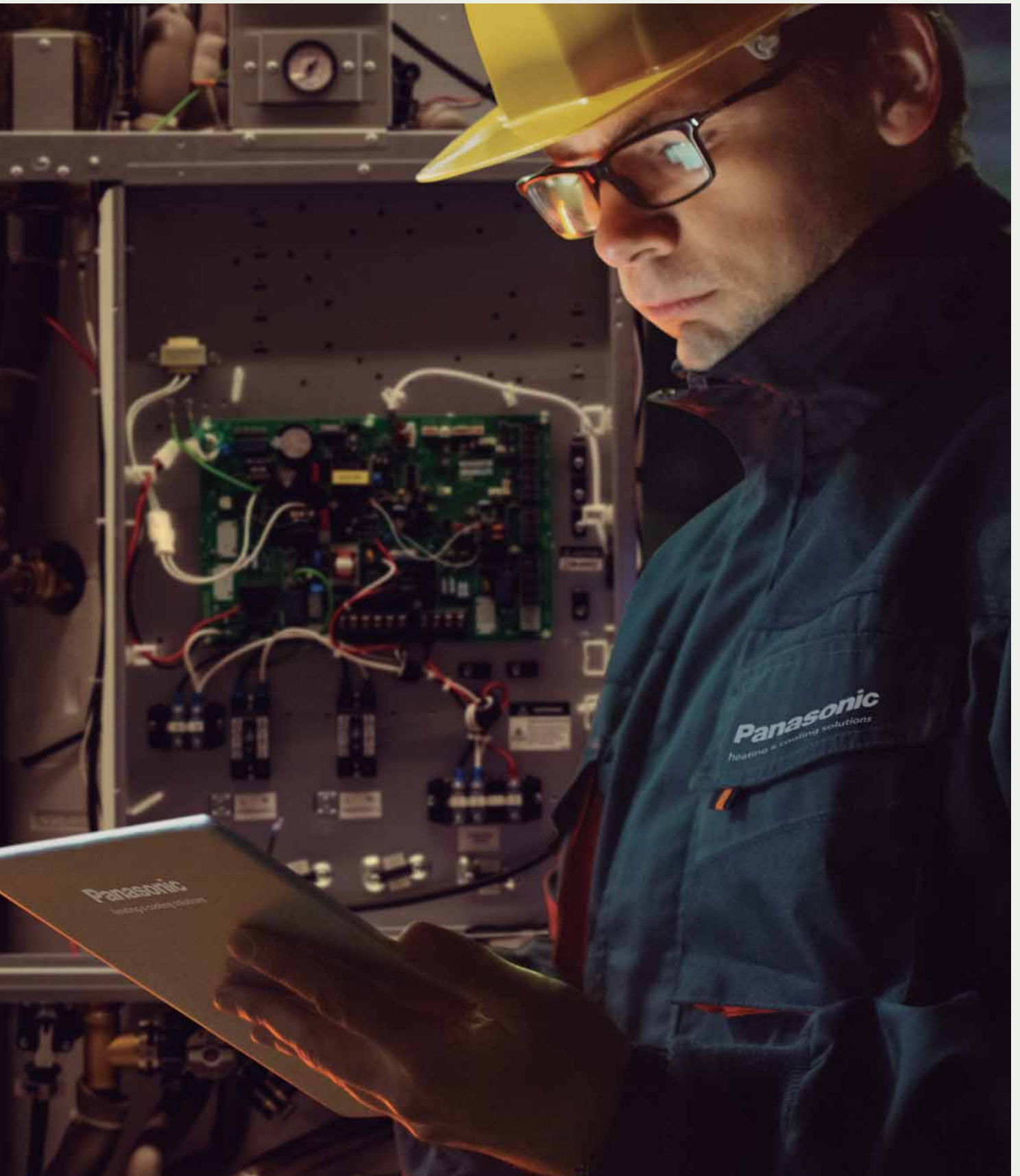

**Panasonic – leading the way in Heating and Cooling.**  
With more than 50 years of experience, selling to more than 120 countries around the world, Panasonic is one of the leaders in the heating and cooling sector.

With a diverse network of production and R&D facilities, Panasonic delivers innovative products incorporating cutting-edge technologies that set the standard for air conditioners worldwide.

Expanding globally, Panasonic provides superior international products transcending borders.



#### 100 % Panasonic: we control the process

The company is also a world leader in innovation as it has filed more than 91539 patents to improve its customers' lives. Moreover, Panasonic is determined to remain at the forefront of its market. In all, the company has produced more than 200 million compressors and its products are manufactured in 294 plants which are located all over the world. You can be assured of the extremely high quality of Panasonic's heat pumps.

This wish to excel has made Panasonic a leading company in heating and turn-key air conditioning solutions. These offer maximum effectiveness, comply with all environmental standards and meet the most avant-garde construction requirements of our time.

#### Constantly Improving

At Panasonic, we know that the best is always yet to come. This is why our air conditioning and heat pump solutions are constantly upgraded. Panasonic is committed to offering our customers innovative products in the heating and cooling market across Europe, and has the ambition to not only meet but also exceed their requirements. Our Technology & Design teams anticipate the needs of tomorrow. We look to produce smaller, quieter, efficient solutions - with better technological features - that can reduce energy consumption while providing suitable temperature conditions for the user.

#### 40 years of experienced organization in Europe

##### The partner for all Europe.

- Full European coverage and integrated organization
- One voice for European Agreements
- Availability and delivery anywhere in Europe
- Specification team to support project design throughout Europe
- European Service Network

##### Trained professionals.

- 22 Training centres in 15 countries
- More than 5000 professionals trained every year. Innovation and manufacture in Europe

##### R&D Department designs solutions for different European needs.

- New factory set up in Czech Republic
- Design software made in Europe for Europe

##### More than Cooling, Heating and Refrigeration Solutions.

- Security, communication solutions, advanced digital signage technology, access control solutions, displays...

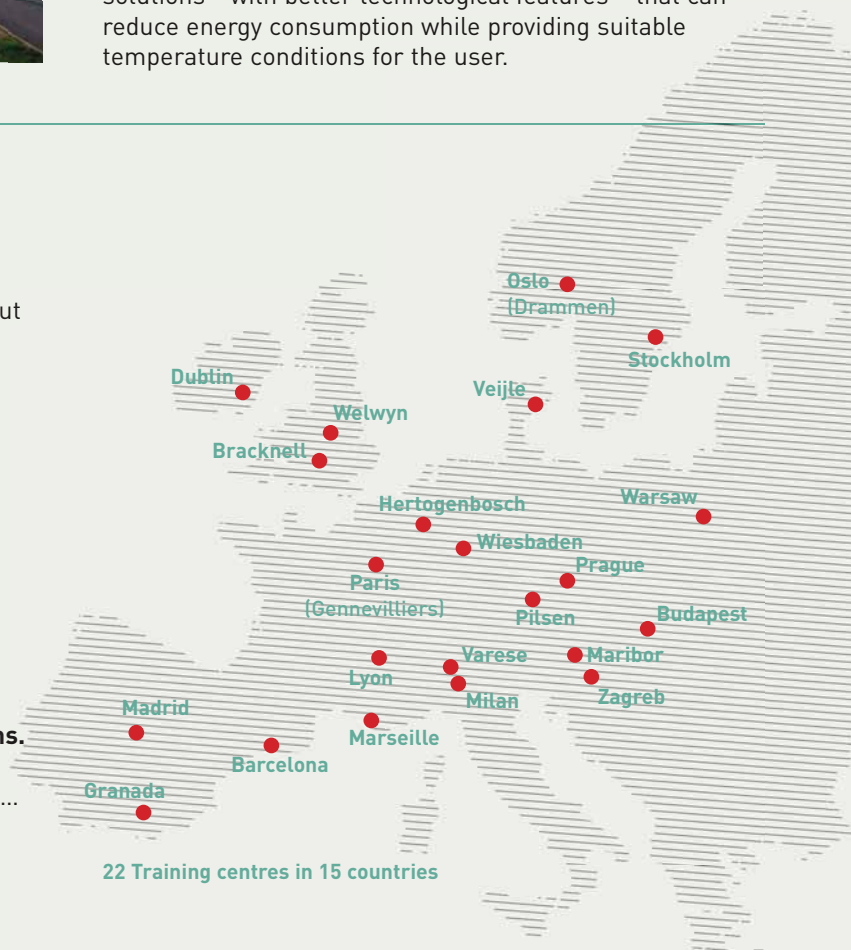

# 100 % Panasonic, the DNA of Japanese craftsmanship

JAPAN  
QUALITY





Applying advanced technologies that truly make life better, we live by an unparalleled commitment to product quality. Panasonic is building on the Japanese tradition of uncompromising quality control worldwide, developing and manufacturing fine products and delivering them to customers everywhere.

### At Panasonic, we believe that the best air conditioner is one that works quietly and effectively in the background whilst minimising its impact on the environment

People who use our products can look forward to long years of high-quality performance without the need for constant service. As part of our rigorous design and development process, Panasonic air conditioners undergo a variety of stringent tests to ensure their effectiveness and long-term reliability. Tests for durability, waterproofing, shock resistance, and noise are conducted on component parts or on the finished products themselves.

As a result of all of these time consuming efforts, Panasonic air conditioners meet industrial standards and regulations in every country where they are sold.

### International Standard Quality

To uphold the company's reputation around the world, Panasonic strives continuously to offer quality with minimized environmental impact.

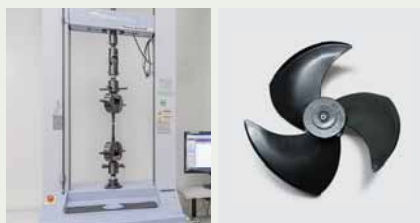

#### Reliable parts that meet or exceed industrial standards.

In every country where they are sold, Panasonic air conditioners comply with all required industrial standards and regulations. In addition, Panasonic conducts stringent testing to ensure the reliability of parts and materials. The strength of the resin material used in a propeller fan is confirmed by a tension test.



#### Compliance with RoHS / REACH substance restrictions.

Panasonic products and used materials strictly comply with chemical substance restrictions as defined by RoHS or REACH. During the development and production of parts, stringent inspections are conducted on over 100 materials to ensure that no hazardous substances are included.



#### Sophisticated production process.

Panasonic's air conditioner production lines employ state-of-the-art factory automation technologies to ensure products are manufactured with high attention to quality to meet expectations of reliability and trustworthiness.

### Durability

At Panasonic we know the importance of a long service life with minimal maintenance. That's why we subject our air conditioners to a wide range of stringent durability tests.



#### Long-term durability test.

To ensure durability and stable operation for many years, we conduct a long-term continuous operation test under conditions that are much more severe than actual operating conditions.



#### Compressor reliability test.

After the continuous operation test, we remove the compressor from a selected outdoor unit, disassemble it, and examine the internal mechanisms and parts for potential failure. This helps ensure reliable long-term performance under harsh conditions.



#### Waterproofing test.

The unit - which is subject to rain and wind - complies with IPX4 waterproof specifications. Contact sections on printed circuit boards are resin-potted to prevent adverse effects caused by exposure to water (an unlikely occurrence).

# Bringing nature's balance indoors

nanoe™ X, technology with the benefits of hydroxyl radicals.

**The well-being benefits of nature are well known – but do you know the power of hydroxyl radicals?**

Abundant in nature, hydroxyl radicals (also known as OH radicals) neutralise pollutants, viruses, and bacteria to clean and deodorise. Technology can bring these incredible benefits indoors so that hard surfaces, soft furnishings, and the indoor environment can be a cleaner and pleasant place to be, whether at home, at work, or visiting hotels, shops, restaurants etc.

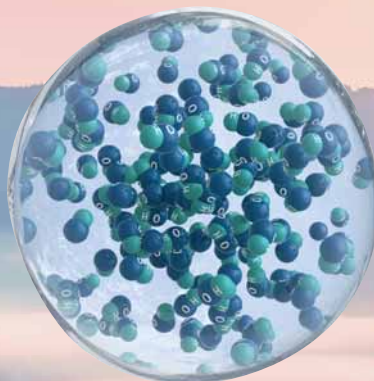

Hydroxyl radicals  
contained in water

In today's health-conscious world, we care about taking exercise, we care about what we eat and what we touch, we also care about what we breathe – and technology exists to bring good outdoor air, indoors.



**Panasonic's nanoe™ X technology takes this a step further and brings nature's detergent – hydroxyl radicals – indoors to help create an ideal environment**

Thanks to the nanoe™ X properties, several types of pollutants can be deactivated such as bacteria, viruses, mould, allergens, pollen and certain hazardous substances.



nanoe™ X reliably reaches pollutants.



Hydroxyl radicals denature pollutants' proteins.



Pollutants activity is inhibited.

**7 effects of nanoe™ X – technology with the benefits of hydroxyl radicals**

\* Refer to <https://aircon.panasonic.eu> for more details and validation data.

**Deodorises**



Odours

**Inhibits 5 types of pollutants**



Bacteria and viruses



Mould



Allergens



Pollen



Hazardous substances



Skin and hair

**International validation**

Effectiveness of nanoe™ technology has been tested by 3rd parties laboratories in Denmark, Malaysia and Japan.

Reduction of 99,9% of Staphylococcus aureus after 8 hours of exposure. Texting organisation: Danish Technological Institute. Report no. 868988.

**99,9 %\*  
OF CERTAIN  
BACTERIA  
INHIBITED**



Denmark



Malaysia



Japan



**First nanoe™ device was developed by Panasonic in 2003**

After annual R&D investments, the technology has been improved with launch of nanoe™ X.

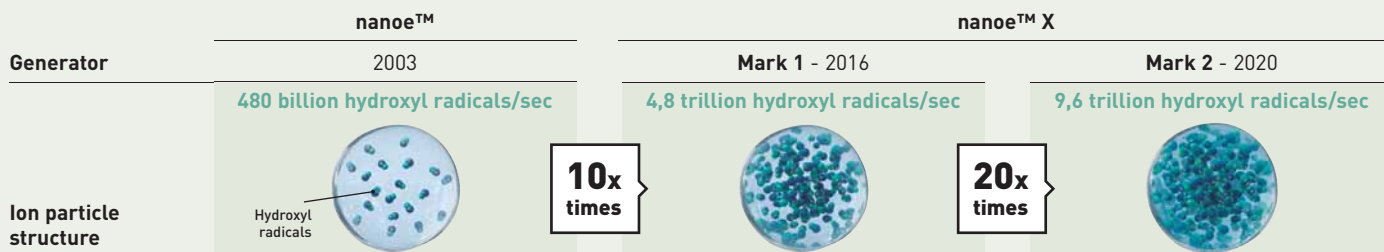

**nanoe™ and nanoe™ X world in Japan**

**PUBLIC TRANSPORT**



JR East. Yamanote line: Adopted for new railcar models

**HOME**

Humidifying air purifiers



Air conditioners

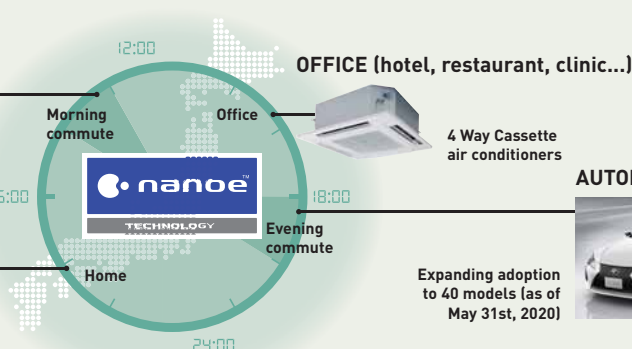

**OFFICE (hotel, restaurant, clinic...)**

Office



4 Way Cassette air conditioners

**AUTOMOTIVE**



TOYOTA  
LEXUS

Expanding adoption to 40 models (as of May 31st, 2020)

## Panasonic: Eco & smart ideas for a sustainable lifestyle



A better life, a better world.  
Panasonic is creating a safe and secure society  
with clean energy.



[www.future-living-berlin.com](http://www.future-living-berlin.com)

**FUTURE LIVING®  
BERLIN**



### Smart City Quarter Berlin

#### **A European Lighthouse Project for Smart Home & Connected Life. Future Living® Berlin.**

The building project Future Living® Berlin is a future model for interconnected urban district. Since 2013 GSW Sigmaringen and Unternehmensgruppe Krebs are developing a model for future living – based on their long term expertise in real estate business and in cooperation with leading international technology companies. In spring 2019 first residents will move into the new quarter.

Future Living® Berlin is making use of the increasing possibility to interconnect products and services. Based on this chance smart and intelligent solutions for future living as well for the single apartments as for the quarter are developed. These solutions are enabling residents to use online services in their intelligent housing environment. Based on these opportunities a concept of living for daily routine is developed offering residents comfort, security and time saving.

A special enhancement of Future Living® Berlin is the pre-configuration for different apartments by experts that enable residents to move into a "ready to go" apartment and be directly supported in their daily routines in an intelligent way. By using one central app or native language single apartments can be steered, adopted and individually expanded by future smart products. Cross-linkage of products and technologies provides all residents with a simple access for an exclusive community

care sharing in the residential quarter which is, of course, based on e-mobility and part of an holistic energy concept containing photo-voltaic systems and battery storage. Cooperating with leading technology companies as project partners a continuous and technological progression is guaranteed in the future. Including residents and learning from their usage data participating partner a ready and enabled to improve the offered solutions pointedly further more.

Beside Future Living® Homes there is Future Living® Dialog offering extensive information and use cases for the general public. The project with it's innovative aims is also representing for sustainability and social solutions. Affordable rental and ancillary rental costs result in apartments available for many target groups. Future Living® Berlin is aiming for conceptional and architectural answers for some of the big challenges of our society as demographical changes, energy turnaround and changing mobility manners. With it's comprehensive solution approach it is unique in Europe.

**Demographic change, energy revolution and mobility change. We offer solutions for the challenges of our time.**

# Projects & Case Studies of Panasonic Heating and Cooling Solutions



Panasonic, a partner with the knowledge and experience to achieve your objectives and green needs.

### Integrated technology that permits better work, easy installation, high efficiency performance, and energy savings

Our main targets are the distributed services and B2B-integrated solutions.

Panasonic provides a single point of contact for the design and maintenance of your system, making things easy for you. Given our experience in processes, technologies and complex business models, we can offer you effective solutions that reduce costs, whilst also being efficient, user-friendly, reliable and innovative. Another advantage we offer to our clients is a support service for systems integration projects, which we provide through our wide range of services and solutions. As a global company, we have at our disposal the financial, logistical and technical resources to develop complex and wide-ranging solutions, both at country and international level by implementing them both on-time and on-budget.



Bulgaria's stand-out residential building with efficient HVAC solution. **Aquarea**



The new Hotel Vincci Gala with efficiency class A, up to 70 % save energy. Barcelona, Spain. **ECOi - ECO G**



New IKEA "Click and Collect" store in city centre. Birmingham, UK. **ECOi - ECO G**



9 high quality homes in Whittle-Le-Woods near Chorley, UK. **Aquarea**



Andalusia Technology Park. Offices of high energetic efficiency. Spain. **ECOi**



14 bubble style domes to bring a 180-degree transparent window to the nature. Belfast, Ireland. **Aquarea**



Madrid's new hotel Only You Atocha. The hotel has 206 rooms distributed over seven floors. **ECO G**



LIAIGRE showroom, well-known as a luxury design architect in Paris, France. **ECOi**



Marina Village Greystones. 205 apartments and 153 houses. Ireland. **Aquarea**



ITK Engineering GmbH. An innovative office building located in Germany. **ECOi - PACi**



Zalando's solution for its warehouse office conversion at Grand Canal Quay, Dublin. **ECOi**



NHS Canford house clinic, Bournemouth, UK. **VRF**

To find out more: [www.aircon.panasonic.eu](http://www.aircon.panasonic.eu)

# Panasonic Heat Pumps with Top Technology





To all that we then add sophisticated and elegant designs. Our heat pumps are like that: innovative inside and beautiful outside.

### Panasonic's heat pumps are the heat source of choice for the future

Leadership isn't something you can just get. You have to show it. Which is why at Panasonic we strive each and every day to make our heat pumps highly reliable and surprisingly efficient, with minimum noise impact and the lowest environmental footprint possible.



### Heatcharge. The energy efficient air to air heating for Nordics

The best proof of our commitment is that we are moving ahead of the sector by including the R32 refrigerant in our entire range of domestic air conditioners, representing an enormous technological lead that manages to combine excellent comfort in the home and perfect harmony with the environment.



#### Heatcharge VZ9SKE

The model has the highest energy class A+++ and offers maximum comfort and energy savings. This powerful air heat pump is designed for commercial and residential environment with extremely high demands on the heating system. Heatcharge has a revolutionary storage technology that captures and stores heat from the compressor. The result is our most reliable and powerful heat pump ever.

### Aquarea. The new generation of energy efficient heating and hot water

Aquarea All in One belongs to the new generation of Panasonic heat pumps for heating, cooling and providing hot water in the home. Aquarea T-CAP is one of the newest heat pumps on the market, and maintains nominal heating capacities even at temperatures as low as -20 °C. This ensures the best possible seasonal energy efficiency ratio. The heat pumps are tested at an outdoor temperature of -23 °C, to ensure the most efficient and stable operation in the Nordic climate.



#### Aquarea All in One J Generation

Compact and easy to install. All in One is a space-saving solution, ideal to install in the laundry room. In addition, Panasonic has developed a range of controls that allow control of two heating zones and cascade systems.

## PRO Club. The professional website of Panasonic



Panasonic PRO Club ([www.panasonicproclub.com](http://www.panasonicproclub.com)) is the online tool which makes your life easier! You just have to register and a lot of functionalities are freely available to you, where ever you are, from your computer or smartphone!

- Print catalogues with your logo and your address
- Download the latest Aquarea designer to define your system and select the good Aquarea Heat pump.
- Calculate the specs of the fan coil based on the parameters of your system
- Get Documents of conformity and all other documents you may need
- Download all the service manuals, end user manuals and installation manuals
- Know what to do with error codes
- Find out about the latest news first
- Register for training

### Highlighted Features.

- Extensive library of resources
- Tools & Apps for end users. Check availability in your country:
  - My Home: sizing wizard for domestic and Air to Water range
  - My Project: Contact form to Panasonic team
  - iFinder: Lists of installers displayed by postcode

- Special offers & promotions
- Training PRO Academy
- Catalogues (Commercial documentation)
- Marketing (Images in high resolution, advertisements, dECO Guidelines)
- Tools (Professional software, sizing tools...)
- Installers customize leaflets in PDF format with their logo & contact details
- Energy label generator. Download energy labels of any device in PDF format
- Heating calculator
- Noise calculator for outdoor unit
- Aquarea Radiator calculator
- Error Code Search by error code or unit ref. Compatible with smartphone and tablet computer
- Revit / CAD Images / Spec texts
- Access to Pananet, online library of technical documentation
- Download Documents of Conformity and other Certifications
- Commissioning online

Panasonic PRO Club is fully compatible with tablet computer and smartphone.



Easy download Panasonic service documentation and brochures



Customise leaflets with your logo & contact details. Save and print the PDF



Energy label generator. Download Energy labels of any device in PDF format



Error Code on your smartphone and your PC: Search by error code or model reference. Online version + downloadable version for offline use

Panasonic has an impressive range of support services for designers, specifiers, engineers and distributors working in the heating and cooling markets.



### Aquarea Designer

This program allows HVAC designers, installers and distributors to identify the correct heat pump for a particular application from Panasonic's Aquarea range, calculate the savings compared to other heat sources and very quickly calculate CO<sub>2</sub> emissions.

Using Panasonic's Aquarea Designer, projects can be developed simply and easily, by either using the Quick Design or Expert Design options. Each allows the user to build up the project data in a simple step-by-step process and choose to output reports (in either Quick or Large formats) as HTML files or as print-outs. To create these useful reports, project data is input, including:

- Heated area
- Heating requirement
- Heating flow and return temperatures
- Climate data (from a simple drop-down menu) including outdoor temperature
- Type of hot water tank, storage capacity and hot water target temperature

Panasonic provides bespoke software helping system designers, installers and dealers to very quickly design and size systems, create wiring diagrams and issue bills of quantities at the push of a button.

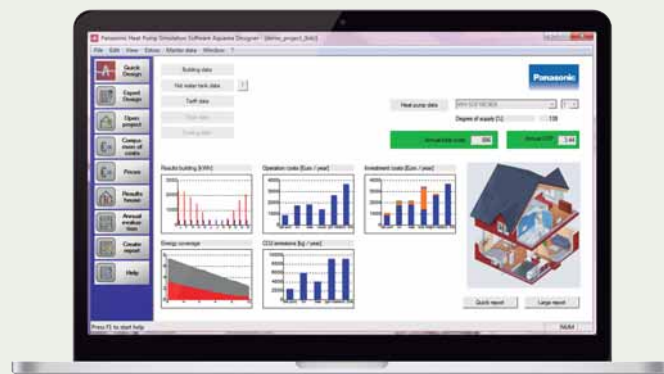

### Aquarea Designer also means saving

Aquarea Designer will calculate the project's energy costs in terms of hot water, heating and pumping. It will show the equipment running times and calculate the COP (coefficient of performance). It then allows the designer to show clients a comparison with other equipment options such as heating by conventional gas-fired boilers, oil systems, wood, standard electric heating and electric night storage heaters. This compares running costs, initial investment costs and maintenance costs. The comparison can also be made for CO<sub>2</sub> emissions and savings.

### The Panasonic PRO Academy

Panasonic takes its responsibility to its distributors, specifiers and installers seriously and has developed a comprehensive Training Programme. The Panasonic Pro-Academy encompasses the traditional hands-on approach to teaching.

New training courses cover three levels. Design, installation, and commissioning & trouble-shooting.

#### Training courses include:

- Domestic applications Air to Air
- Aquarea air source heat pumps
- VRF ECOi

The courses are offered on site at Panasonic's premises across Europe. The Training Centres display Panasonic's latest product range and give delegates an opportunity to get a hands-on experience with the latest controllers, indoor and outdoor units from the VRF ECOi, Etherea, GHP and Aquarea ranges.

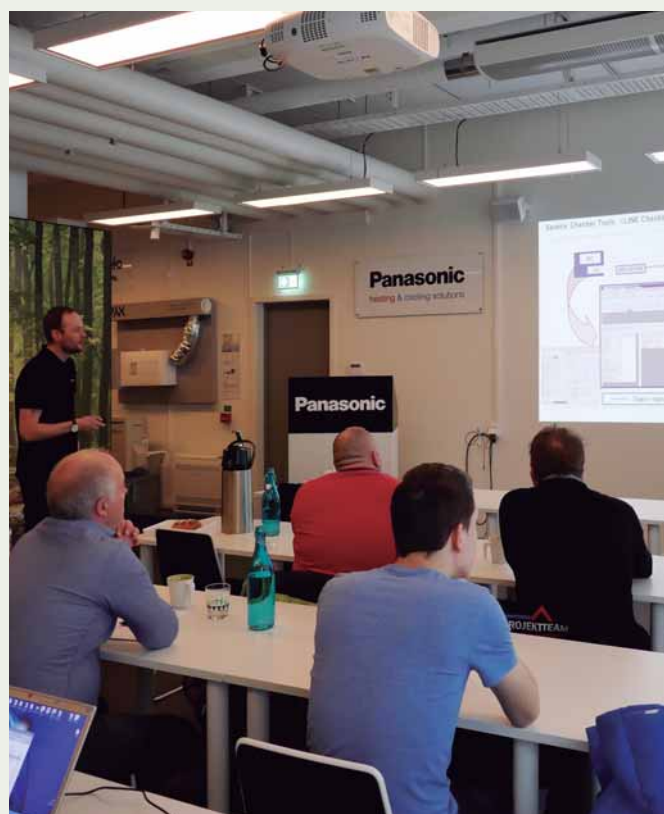

Download on  
[www.panasonicproclub.com](http://www.panasonicproclub.com) or connect  
simply with your smartphone to the PRO  
Club using this QR

AQUAREA



## Welcome to Aquarea air to water heat pump

Aquarea's Air to Water Heat Pump for residential and commercial applications. Offering capacities from 3 kW all the way through to 16 kW, the Aquarea Heat Pump Range is the widest on the market, ensuring a system is available, whatever your heating and cooling needs. Suitable for new build and refurbishment projects, the solutions are cost-effective with minimised environmental impact.

## Aquarea J generation R32.

Aquarea is now available in R32, making Aquarea excellent choice for those who really care the environment. Aquarea J Series, the new generation designed for R32 refrigerant includes many other improvements: high piping range, chiller function cooling down to 10 °C, DHW COP up to 3,3, improved backup heater function for real bivalent function, SG Ready and PV function for cooling, heating curve down to -20 °C, fixed or auto water pump speed, magnet filter, efficient or comfort mode for DHW, and other improvements to bring more value and to make installation easier.



## New Aquarea All in One Compact.

The Aquarea All in One Compact unit is the ultimate space-saving solution. Its 598 x 600 mm footprint, standard size of other big appliances, reduces the space required for the installation. Supplying efficient heating, the unit generates domestic hot water and stores it inside a 185L stainless steel tank with U-Vacua™ insulation to reduce energy losses. Being a real All-in-one unit, the number of additional components is reduced and the installation time is shortened.

## Aquarea Service Cloud for professionals.

Aquarea Service Cloud will activate remote maintenance service while the end user is controlling and monitoring its heating and DHW remotely. This remote maintenance will save time and installation visits by connecting Aquarea to a powerful cloud infrastructure. Remote checker, remote error codes, remote set-up functions... all this will be possible by installers with CZ-TAW1 and end user acceptance.



## New residential heat recovery solution.

Ventilation systems with heat recovery offer users a high degree of living comfort thanks to temperature controlled and clean air. Heat recovery units in combination with Aquarea heat pump are the ideal solution for house owners which are looking for high performance and maximum comfort.

## Advanced cascade control.

The Cascade Manager enables the control of up to 10 Aquarea heat pumps. Among others, it offers features like DHW logic, control of 3-way valves, Modbus IP for BMS communication, connection of up to 3 M-Bus electricity meters, PV demand functions, quick set-up and easy control by the integrated touch display.



# Aquarea, top-level efficiency across the board



**Aquarea J Generation: much more than Aquarea in R32. Available in 3/5/7/9 kW All in One, Bi-bloc and 5/7/9 kW Mono-bloc.**

## 1 Keeping Aquarea essence

- Free space on the top of All in One
- A+++ in heating mode at 35 °C (scale from A+++ to D)
- Service Cloud by accessory

## 2 Higher efficiency

- SCOP up to + 5 % vs H Generation
- DHW COP up to 3,30 (for 3 and 5 kW models)

## 3 More flexibility in design

- 60 °C water temperature
- Piping length improved: 7/9 kW: 50/30 m (up to 40 m without minimum floor area\*) - 3/5 kW: 25/20 m
- Chiller function cooling down to 10 °C outdoor temperature

\* With a 5 % decrease of the capacity.

## 4 New smart functions

- SG ready for heating, cooling and DHW modes
- Utility remote bivalent control: By dry contacts\*
- Stop external device when defrost by Dry contact (for fan coil fan stop)\*

\* Can not be used at same time.

## 5 More comfort

- Better comfort in extreme low temperature: Heating curve can be set up down to -20 °C
- Efficient or comfort mode for DHW: Part load for better efficiency or full load to reduce the heat up time
- DHW two sensor position selectable for All in One: Efficient position (best DHW COP) or bigger volume of hot water

Other improvements: More silent outdoor units / Magnet filter for water cycle.

## R32 refrigerant gas: A 'small' change that changes everything

**Panasonic recommends R32 because it is comparably environmentally friendly. Compared to R22 and R410A, R32 has a very low potential impact on the depletion of ozone layer and global warming.**

In line with the European countries who are concerned in protecting and maintaining the environment by participating in the Montreal Protocol to protect the Ozone Layer and prevent Global Warming, Panasonic is leading the switch to R32.

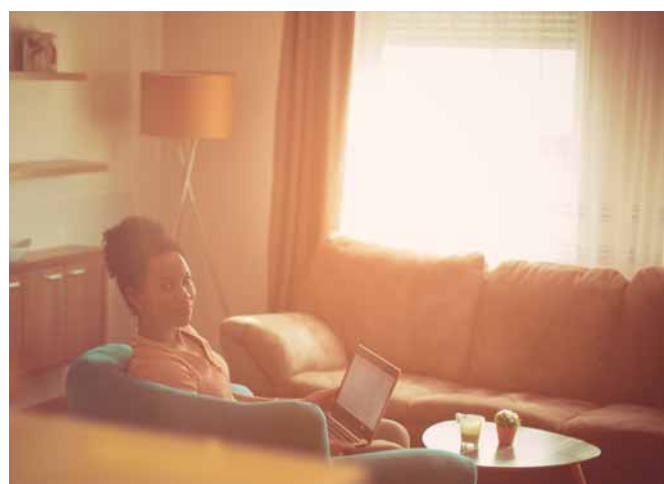

## Aquarea H Generation.

The beauty of comfort. The H Generation is available from 3 to 16 kW. The small capacities are specially designed for low energy homes and achieve an impressive COP of 5 (on the 3 kW).

### Better Efficiency & Value A++/A+++.

- A++ for medium temperature applications (radiators. ErP 55 °C in the scale from A+++ to D)
- A+++ for low temperature applications (floor heating. ErP 35 °C in the scale from A+++ to D)

## Aquarea, a generation of energy efficient heating and hot water.

Thanks to the system's high degree of technology and advanced control, it is able to maintain a high output capacity and efficiency even at -7 °C and -15 °C. The Aquarea's software can be set for the requirements of low consumption homes in order to maximise energy efficiency. Whatever the weather, Aquarea can work even at -28 °C (for T-CAP All in One and Bi-bloc) lower limit. The compact design of the outdoor unit makes installation very easy.

# Aquarea commercial

Restaurant with Aquarea

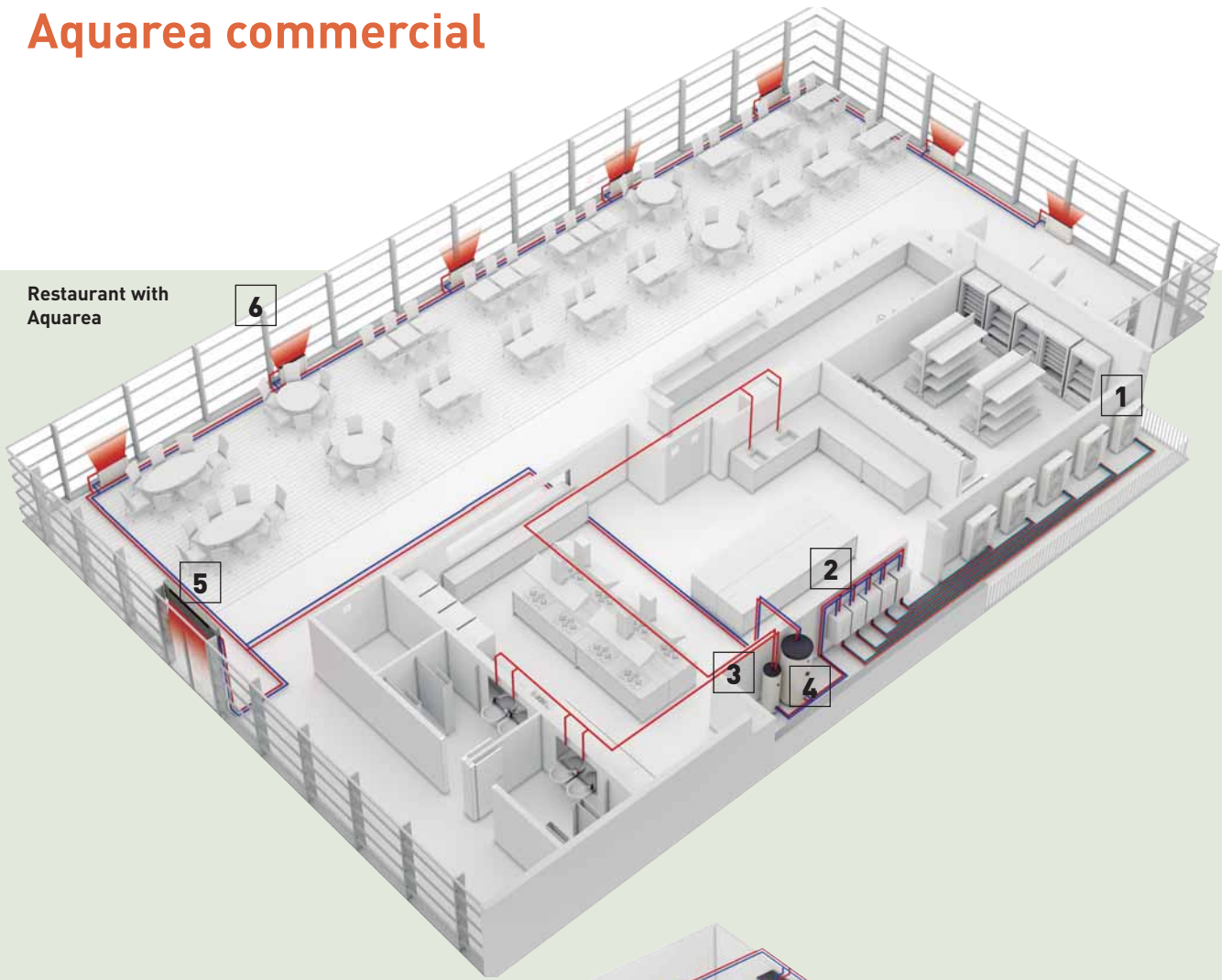

Supermarket with Aquarea

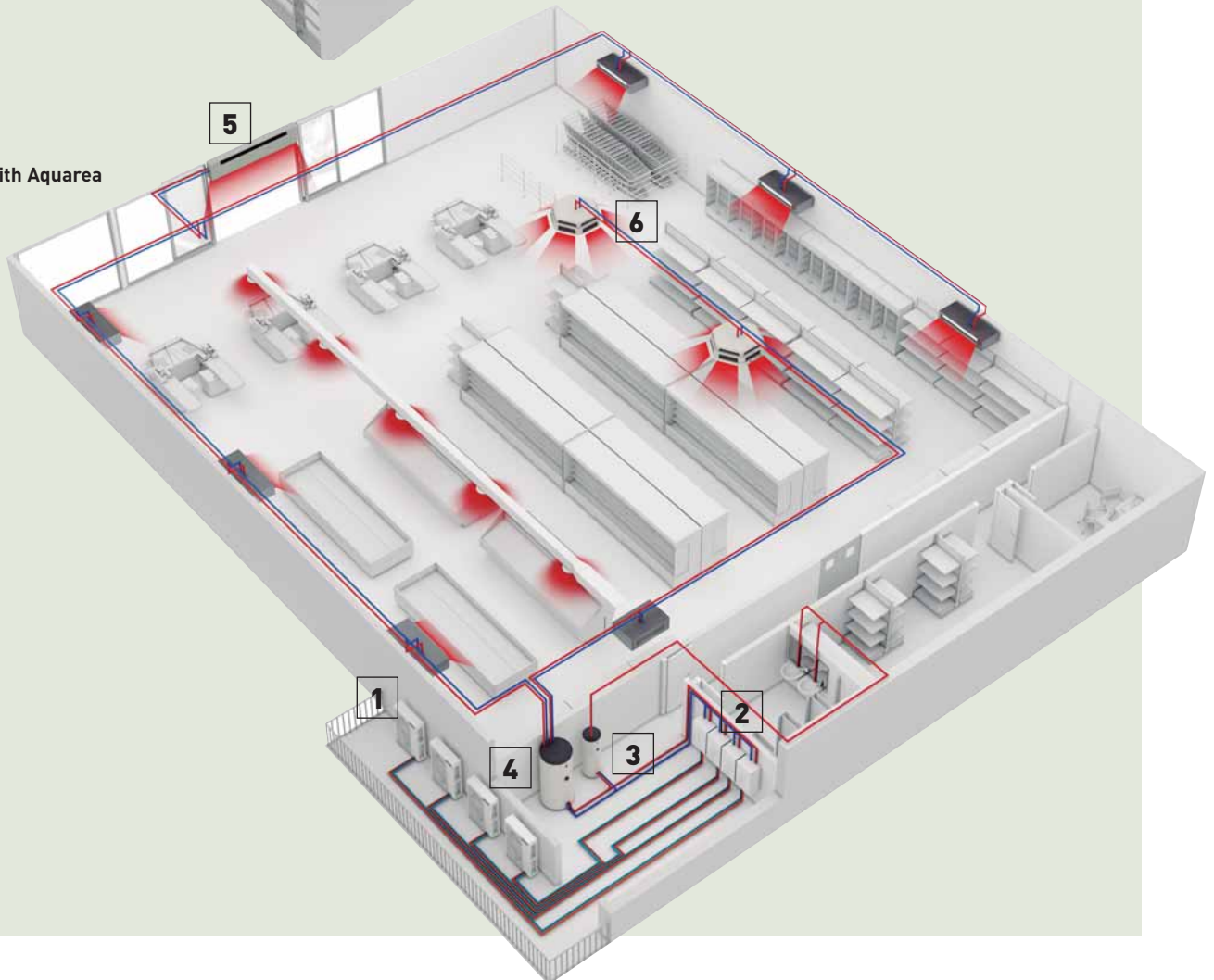



**Solutions for best savings. Efficient Panasonic heat pumps can help to significantly reduce the energy consumption of your business.**

Panasonic Aquarea Heat Pumps offer space saving, energy-efficient heating and can be easily adapted for installation in flats, houses and commercial premises. Businesses producing heating, cooling and big quantities of hot water at 65 °C, such as restaurants or supermarkets, installing an Aquarea Heat Pump system can also use this wasted heat to improve energy efficiency further.

Heat pump technology is scalable, meaning that it can be installed in buildings of varying sizes, offering both small and large-scale heating solutions. The technology is also environmentally friendly when compared to traditional

heating systems alternatives based on fossil fuel energy and in addition it is more energy efficient.

**Key points:**

- Efficient hot water production
- Fast return of investment
- Easy control
- Easy integration in the existing water system: fan coils, floor heating, domestic hot water tanks, etc
- Very good part load management
- High efficiency

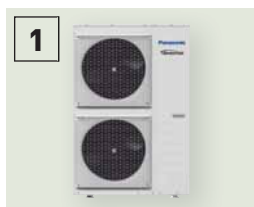

**1 Aquarea T-CAP.**  
16 kW heat pumps on cascade mode. T-CAP line-up is an ideal replacement for old gas/oil boilers.



**2 High efficiency Aquarea T-CAP hydromodule.**  
Indoor unit of Aquarea Bi-bloc systems. When a Mono-bloc system is used, the hydromodule is integrated in the outdoor unit.



**3 Super high efficiency Tanks.**  
Combining Panasonic Aquarea with a high efficiency tank ensures the desired volume of hot water, at the correct temperature while reduced energy costs.

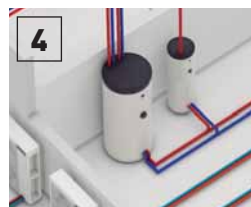

**4 Buffer Tank.**  
Panasonic Aquarea can be combined with the hydraulic elements of the new or existing water system.

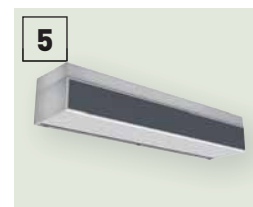

**5 Air Curtain with water Coil.**  
Water coil air curtains can be used in the hydraulic system to have efficient performance of the water system.

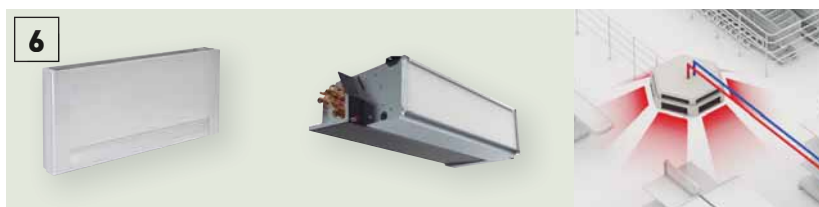

**6 Fan coils for heating and cooling.**  
Aquarea heat pumps can be easily connected to the existing water system: 2 way and 4 way fan coils, floor heating, DHW tanks...

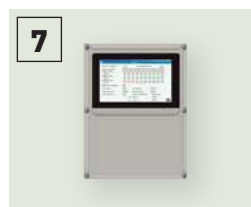

**7 Cascade manager.**  
The Cascade manager enables the control of up to 10 Aquarea heat pumps (balancing the working hours and making the operation more efficient) and up to 2 buffer tanks.



**8 BMS integration.**  
The cascade system can be easily integrated in a Modbus project thanks to the Cascade manager.



**Burger & Lobster restaurant. Bath, UK.**  
Panasonic's air-to-water Aquarea system has been installed in the latest glamorous Burger & Lobster restaurant in Bath. The Octagon Chapel, a large listed building in the city centre, was converted to accommodate the restaurant, and Panasonic's Aquarea system provided an extensive, energy efficient and unobtrusive heating and cooling solution.



**Carluccio's restaurant. UK.**  
One of UK's leading Italian restaurant, Carluccio's, wanted to install a system which would provide the desired volume of hot water, at the correct temperature while at the same time reduced energy costs. FWP installed a 12 kW Aquarea T-CAP mono bloc unit which would allow for the free air from the kitchen roof space to be transferred through condensing unit providing hot water at the optimum temperature.

# Aquarea Heat Pump Line-Up

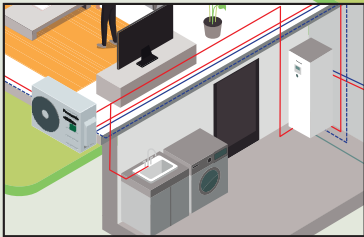
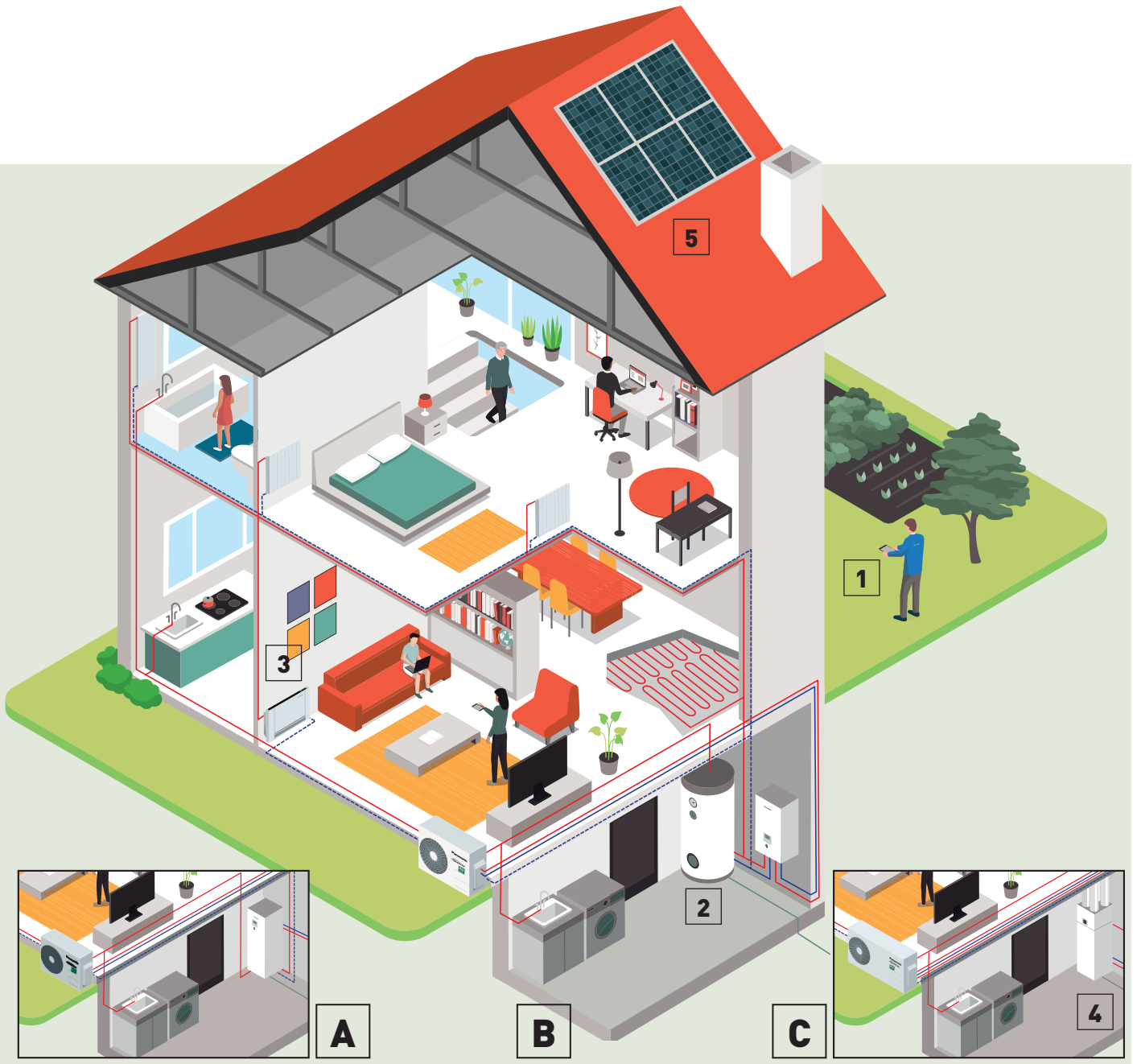

**A**

**B**

**C**

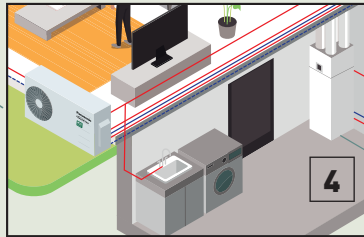

**4**



**A** All in One system.



**B** Bi-bloc system.

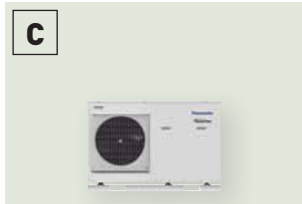

**C** Mono-bloc system.

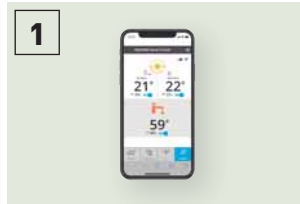

**1** Control through smartphone, tablet or computer (optional).



**2** Super High Efficiency cylinder (optional).

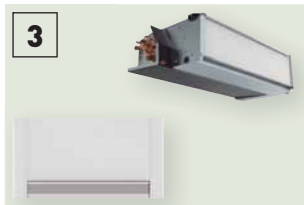

**3** Fan coils for heating and cooling (optional).



**4** Heat Recovery Ventilation + DHW Tank (optional).

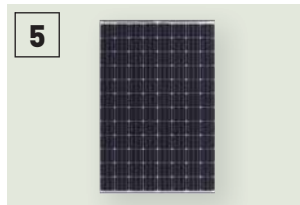

**5** Heat Pump + HIT Photovoltaic solar panel (optional).

Panasonic Aquarea offers you solutions, helping to make the home more efficient and the installation cheaper and easier.

### Aquarea High Performance

**For new installations and low consumption homes.**

Outstanding efficiency and energy savings with minimised CO<sub>2</sub> emissions and minimum space. Improved performance with COPs up to 5,33 for J Generation 3 kW.

### Aquarea T-CAP

**For extremely low temperatures, refurbishment and innovation.**

Ideal to ensure that the heating capacity is maintained even at very low temperatures. This line-up is able to maintain the heat pump output capacity until -20 °C outdoor temperature without the help of an electrical booster heater.

### Aquarea HT













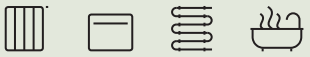
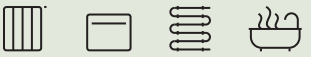

**For a house with old high-temperature radiators.**

Ideal for retrofit: green energy source works with existing radiators. Aquarea HT Solution is the most appropriate, providing output water temperatures of 65 °C even at outdoor temperatures as low as -15 °C.

### DHW Stand Alone

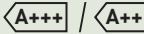
**Highly efficient heat pump water heater.**

Ideal to cover the hot water needs of a family house, stand alone DHW heat pumps are designed to provide maximum comfort and savings in the production of DHW. Consumption of the A+ DHW heat pump is reduced by 75 % compared with traditional electric water heaters.

Aquarea High Performance	Aquarea T-CAP	Aquarea HT	DHW Stand Alone
			
Heating - Cooling - DHW Single Phase from 3 to 16 kW Three Phase from 9 to 16 kW	Heating - Cooling - DHW Single Phase from 9 to 12 kW Three Phase from 9 to 16 kW	Heating - DHW Single Phase from 9 to 12 kW Three Phase from 9 to 12 kW	Only DHW From 100 to 270L
Connectable to			
			
Radiators - Fan coil - Underfloor heating - DHW	Radiators - Fan coil - Underfloor heating - DHW	Traditional high-temperature radiators - DHW	Domestic hot water
Application			
			
Normal installation	For extreme cold ambient	Retrofit for old radiators	Only DHW
Energy efficiency			
			
Heating 35 °C / 55 °C <sup>1)</sup>	Heating 35 °C / 55 °C <sup>1)</sup>	Heating 35 °C / 55 °C <sup>1)</sup>	DHW 50 ~ 62 °C <sup>2)</sup>
Minimum outdoor temperature			
-20 °C <sup>3)</sup>	-28 °C [All in One and Bi-bloc] -20 °C [Mono-bloc] <sup>4)</sup>	-20 °C <sup>3)</sup>	-5 °C
Minimum outdoor temperature to provide constant capacity at 35 °C supply water temperature			
-7 °C (not for all units)	-20 °C <sup>4)</sup>	-15 °C	—
Supply temperature for heating. Maximum / Heat pump only			
75 °C <sup>5)</sup> / 55 °C <sup>6)</sup> (or 60 °C for Aquarea J Generation)	75 °C <sup>5)</sup> / 60 °C <sup>6)</sup>	75 °C <sup>5)</sup> / 65 °C	—
Control and connectivity			
Smart Grid Ready <sup>7)</sup> Wireless LAN Ready	Smart Grid Ready <sup>7)</sup> Wireless LAN Ready	—	—
Range			
Bi-bloc from 3 to 16 kW Mono-bloc from 5 to 16 kW All in One from 3 to 16 kW (185L)	Bi-bloc from 9 to 16 kW Mono-bloc from 9 to 16 kW All in One from 9 to 16 kW (185L)	Bi-bloc from 9 to 12 kW Mono-bloc from 9 to 12 kW	Wall-mounted 100 and 150L Floor-standing 200 and 270L

All data in this chart is applicable in most of models in each line up, check product specs to confirm. 1) Scale from A+++ to D. 2) Scale from A+ to F. 3) After cut-off at -23 °C compressor restarts at -20 °C. 4) 9 and 12 kW. 5) DHW maximum temperature with heater. 6) In case of outdoor temperature over -10 °C. 7) H Generation with CZ-NS4P, F and G Generation with Heat Pump Manager. \* DHW Stand Alone is produced by S.A.T.E.

# Aquarea Smart Cloud for end users

The most advanced heating control for today and for the future. Aquarea can be connected to the Cloud with CZ-TAW1, enabling both end user control and remote maintenance by service partners.

WATCH DEMO ▶



\* User interface image may change without notification.

## Easy and powerful energy management

The Aquarea Smart Cloud is much more than a simple thermostat for switching a heating device ON or OFF. It is a powerful and intuitive service for remotely controlling the full range of heating and hot water functions, including monitoring energy consumption.

## How does it work?

After connecting an Aquarea J or H generation to the cloud by wireless LAN or by wired LAN, the user accesses the Cloud portal to remotely operate all functions of his units. He can also permit service partners to access customised functions for remote maintenance and monitoring.

## Requirements

1. Aquarea J or H Generation
2. In-house internet connection with router wireless LAN or wired LAN
3. Get a Panasonic ID in <https://aquarea-smart.panasonic.com/>

## Functions:

- Visualization and Control
- Scheduling
- Energy Statistics
- Malfunction notification

Works with IFTTT



## More possibilities with IFTTT.

**IF This Then That: IFTTT service enables user to automatically trigger actions for Aquarea system based on other apps, web services or devices.**

Connect your Aquarea to your voice assistant, get an e-mail if your Aquarea gets an error or automatically turn on your Aquarea on Heat Mode when outdoor temperature drops below specified level.

## Advantages

Energy savings, comfort and control from anywhere. Increased efficiency and resources management, operating costs savings and owner satisfaction. The Aquarea Smart Cloud services are focused on enabling full remote maintenance of the Aquarea system. This allows maintenance specialists to engage in predictive maintenance and system fine-tuning, as well as fixing malfunctions when they occur.

Aquarea compatibility	J and H Generation
Connection point	CN-CNT Aquarea port
Home router connection	Wireless or wired LAN
Temperature sensor	Can use remote controller sensor
Tablet or PC browser compatibility*	Yes
Operation from remote — ON/OFF — Temperature setting Mode selection — DHW setting — Error codes — Scheduling	Yes
Heating areas	Up to 2 zones
Power consumption estimation — Operation log history	Yes — Yes

\* Check browsers and version compatibility.

# Aquarea Service Cloud for Installers / Maintenance

WATCH DEMO ▶



## The real remote maintenance made simple

The Aquarea Service Cloud allows installers to take care of their customers' heating systems remotely. It saves time and money and shortens the response time, thus increasing the customers' satisfaction.

### Advanced functions for remote maintenance with professional screens:

- Global view at a glance
- Error log history
- Full unit information
- Statistics always available
- Most settings available

#### Home page.

Status of connected users at a glance. 2 view options: map view or list view.

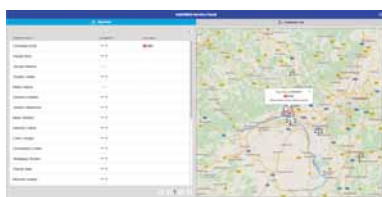

#### Status tab.

Current status of unit with a maximum 28 parameters.



#### Statistics tab.

Customisable statistics of a maximum of 71 parameters. Available anytime with the information of the last 7 days.

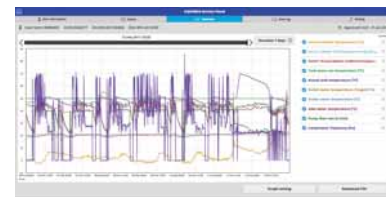

#### Settings tab.

Most of the user and installer settings can be done remotely.



## Activation of the Aquarea Service Cloud

### Requirements.

Hardware and connection	End user registration	Installer / maintenance registration
J or H Generation Aquarea connected to CZ-TAW1	Get Panasonic ID	Get Service ID
In-house internet connection with Wireless LAN or wired LAN	Aquarea Smart Cloud	Aquarea Service Cloud

### Connecting the unit to the Aquarea Service Cloud.

The process can be initiated by the end user or by the installer.

The end user can select and change the installer's level of control anytime (4 levels).

**Installer registration:** <https://aquarea-service.panasonic.com/>

**End user registration:** <https://aquarea-smart.panasonic.com/>

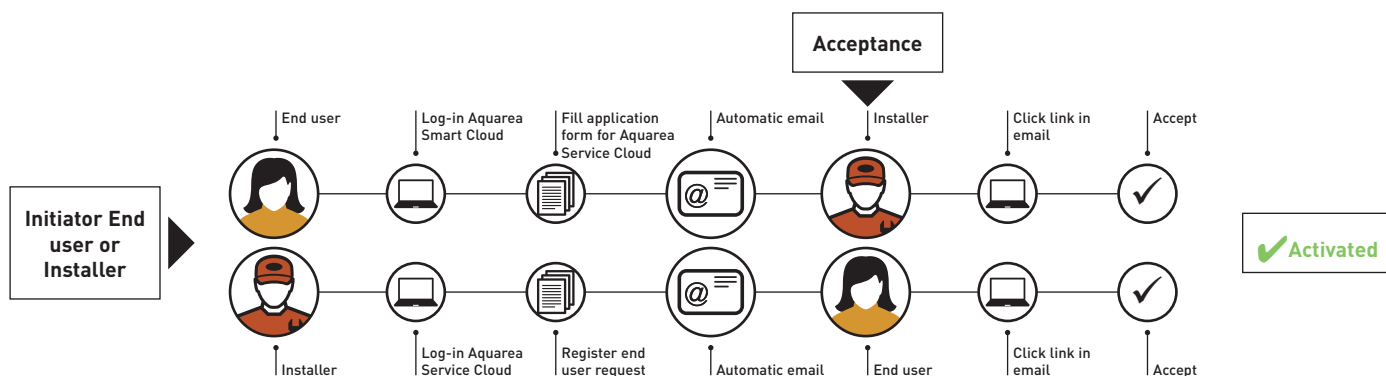

# Aquarea Heat Pumps Line-Up

		3 kW	5 kW	7 kW
<b>Aquarea High Performance</b> P. 32, 36, 37	<b>All in One</b> 1 Phase 3 Phase 	 WH-ADC0309J3E5 WH-ADC0309J3E5B WH-UD03JE5 WH-ADC0309H3E5 WH-ADC0309H3E5B WH-UD03HE5-1	 WH-ADC0309J3E5 WH-ADC0309J3E5B WH-UD05JE5 WH-ADC0309H3E5 WH-ADC0309H3E5B WH-UD05HE5-1	 WH-ADC0309J3E5 WH-ADC0309J3E5B WH-UD07JE5 WH-ADC0309H3E5 WH-ADC0309H3E5B WH-UD07HE5-1
P. 33	<b>NEW All in One Compact</b> 1 Phase 	 <b>NEW</b> WH-ADC0309J3E5C <sup>1)</sup> WH-UD03JE5	 <b>NEW</b> WH-ADC0309J3E5C <sup>1)</sup> WH-UD05JE5	 <b>NEW</b> WH-ADC0309J3E5C <sup>1)</sup> WH-UD07JE5
P. 34, 40, 41	<b>Bi-bloc</b> 1 Phase 3 Phase 	 WH-SDC0305J3E5 WH-UD03JE5 WH-SDC03H3E5-1 WH-UD03HE5-1	 WH-SDC0305J3E5 WH-UD05JE5 WH-SDC05H3E5-1 WH-UD05HE5-1	 WH-SDC0709J3E5 WH-UD07JE5 WH-SDC07H3E5-1 WH-UD07HE5-1
P. 35, 44	<b>Mono-bloc</b> 1 Phase 		 <b>NEW</b> WH-MDC05J3E5 <sup>2)</sup> WH-MDC05H3E5	 <b>NEW</b> WH-MDC07J3E5 <sup>2)</sup> WH-MDC07H3E5
<b>Aquarea T-CAP</b> P. 38, 39	<b>All in One</b> 1 Phase 3 Phase 			
P. 42, 43	<b>Bi-bloc</b> 1 Phase 3 Phase 			
P. 45	<b>Mono-bloc</b> 1 Phase 3 Phase 			
<b>Aquarea HT</b> P. 46	<b>Bi-bloc</b> 1 Phase 3 Phase 			
P. 47	<b>Mono-bloc</b> 1 Phase 			

Heating, Cooling, DHW. WH-\_\_E5 1 Phase // WH-\_\_E8 3 Phase. Green references refer to R32 models. 1) Available in Autumn 2020. 2) Available in May 2020.

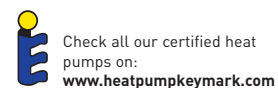

9 kW

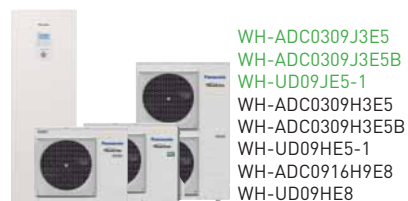

WH-ADC0309J3E5  
 WH-ADC0309J3E5B  
 WH-UD09JE5-1  
 WH-ADC0309H3E5  
 WH-ADC0309H3E5B  
 WH-UD09HE5-1  
 WH-ADC0916H9E8  
 WH-UD09HE8

12 kW

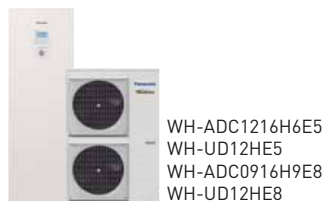

WH-ADC1216H6E5  
 WH-UD12HE5  
 WH-ADC0916H9E8  
 WH-UD12HE8

16 kW

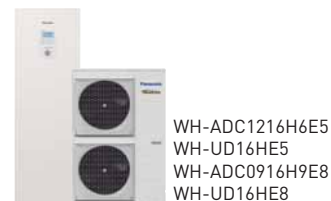

WH-ADC1216H6E5  
 WH-UD16HE5  
 WH-ADC0916H9E8  
 WH-UD16HE8



**NEW**  
 WH-ADC0309J3E5C <sup>1)</sup>  
 WH-UD09JE5-1

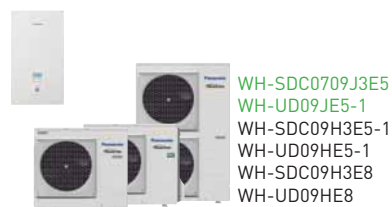

WH-SDC0709J3E5  
 WH-UD09JE5-1  
 WH-SDC09H3E5-1  
 WH-UD09HE5-1  
 WH-SDC09H3E8  
 WH-UD09HE8



WH-SDC12H6E5  
 WH-UD12HE5  
 WH-SDC12H9E8  
 WH-UD12HE8



WH-SDC16H6E5  
 WH-UD16HE5  
 WH-SDC16H9E8  
 WH-UD16HE8



**NEW**  
 WH-MDC09J3E5 <sup>2)</sup>  
 WH-MDC09H3E5



WH-MDC12H6E5



WH-MDC16H6E5



WH-ADC1216H6E5  
 WH-UX09HE5  
 WH-ADC0916H9E8  
 WH-UX09HE8  
 WH-ADC0916H9E8  
 WH-UQ09HE8



WH-ADC1216H6E5  
 WH-UX12HE5  
 WH-ADC0916H9E8  
 WH-UX12HE8  
 WH-ADC0916H9E8  
 WH-UQ12HE8



WH-ADC0916H9E8  
 WH-UX16HE8  
 WH-ADC0916H9E8  
 WH-UQ16HE8



WH-SXC09H3E5  
 WH-UX09HE5  
 WH-SXC09H3E8  
 WH-UX09HE8  
 WH-SQC09H3E8  
 WH-UQ09HE8



WH-SXC12H6E5  
 WH-UX12HE5  
 WH-SXC12H9E8  
 WH-UX12HE8  
 WH-SQC12H9E8  
 WH-UQ12HE8



WH-SXC16H9E8  
 WH-UX16HE8  
 WH-SQC16H9E8  
 WH-UQ16HE8



WH-MXC09H3E5  
 WH-MXC09H3E8



WH-MXC12H6E5  
 WH-MXC12H9E8



WH-MXC16H9E8

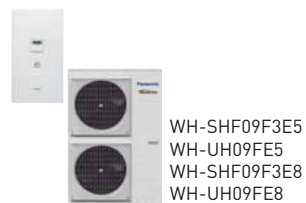

WH-SHF09F3E5  
 WH-UH09FE5  
 WH-SHF09F3E8  
 WH-UH09FE8



WH-SHF12F6E5  
 WH-UH12FE5  
 WH-SHF12F9E8  
 WH-UH12FE8



WH-MHF09G3E5



WH-MHF12G6E5



011-1W0207  
011-1W0208  
011-1W0209

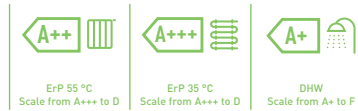

**CZ-TAW1**  
Cloud connection.  
For user control and  
installer remote  
maintenance.

## Aquarea High Performance All in One J Generation Single Phase. Heating and Cooling 1 or 2 zones • R32 refrigerant

		Single Phase (Power to indoor)			
Kit 1 zone (for 2 zone add B at the end)		KIT-ADC03JE5	KIT-ADC05JE5	KIT-ADC07JE5	KIT-ADC09JE5-1
Heating capacity / COP (A +7 °C, W 35 °C)	kW / COP	3,20/5,33	5,00/5,00	7,00/4,76	9,00/4,48
Heating capacity / COP (A +7 °C, W 55 °C)	kW / COP	3,20/2,81	5,00/2,72	7,00/2,82	8,95/2,78
Heating capacity / COP (A +2 °C, W 35 °C)	kW / COP	3,20/3,64	4,20/3,18	6,85/3,41	7,00/3,40
Heating capacity / COP (A +2 °C, W 55 °C)	kW / COP	3,20/2,19	4,10/1,99	6,20/2,21	6,30/2,16
Heating capacity / COP (A -7 °C, W 35 °C)	kW / COP	3,30/2,80	4,20/2,59	5,60/2,87	6,12/2,78
Heating capacity / COP (A -7 °C, W 55 °C)	kW / COP	3,20/1,79	3,55/1,71	5,25/1,94	5,90/1,93
Cooling capacity / EER (A 35 °C, W 7 °C)	kW / EER	3,20/3,52	4,50/3,00	6,70/3,03	8,20/2,72
Cooling capacity / EER (A 35 °C, W 18 °C)	kW / EER	3,20/4,85	4,80/4,29	6,70/4,72	9,00/4,18
Seasonal energy efficiency - Heating average climate (W35 °C / W55 °C)	ηs %	200/136	200/136	193/130	193/130
	SCOP	5,07/3,47	5,07/3,47	4,90/3,32	4,90/3,32
Energy class heating average climate (W35 °C / W55 °C) <sup>1)</sup>	A+++ to D	A+++ / A++	A+++ / A++	A+++ / A++	A+++ / A++
<b>Indoor unit 1 zone hydrokit</b>		<b>WH-ADC0309J3E5</b>	<b>WH-ADC0309J3E5</b>	<b>WH-ADC0309J3E5</b>	<b>WH-ADC0309J3E5</b>
<b>Indoor unit 2 zones built-in hydrokit</b>		<b>WH-ADC0309J3E5B</b>	<b>WH-ADC0309J3E5B</b>	<b>WH-ADC0309J3E5B</b>	<b>WH-ADC0309J3E5B</b>
Sound pressure	Heat / Cool	28/28	28/28	28/28	28/28
Dimension	HxWxD	1800x598x717	1800x598x717	1800x598x717	1800x598x717
Net weight 1 zone / 2 zones		122/130	122/130	122/130	122/130
Water pipe connector		R 1½	R 1½	R 1½	R 1½
A class pump	Number of speeds	Variable Speed	Variable Speed	Variable Speed	Variable Speed
	Input power (Min/Max)	30/120	30/120	30/120	30/120
Heating water flow (ΔT=5 K, 35 °C)	L/min	9,20	14,30	20,10	25,80
Capacity of integrated electric heater	kW	3,00	3,00	3,00	3,00
Power supply 1	A	12,0	12,0	15,9	15,9
Power supply 2	A	13,0	13,0	13,0	13,0
Recommended cable size, supply 1 / 2	mm²	3x1,5/3x1,5	3x1,5/3x1,5	3x2,5/3x1,5	3x2,5/3x1,5
Water volume	L	185	185	185	185
Maximum water temperature	°C	65	65	65	65
Material inside tank		Stainless steel	Stainless steel	Stainless steel	Stainless steel
Tapping profile according EN16147		L	L	L	L
DHW tank ErP average climate efficiency rating <sup>2)</sup>	A+ to F	A+	A+	A+	A+
DHW tank ErP average climate η / SCOP	ηwh % / SCOP	132/3,30	132/3,30	120/3,00	120/3,00
<b>Outdoor unit</b>		<b>WH-UD03JE5</b>	<b>WH-UD05JE5</b>	<b>WH-UD07JE5</b>	<b>WH-UD09JE5-1</b>
Sound power part load <sup>3)</sup>	Heat	55	55	59	59
Sound power full load	Heat / Cool	60/61	64/64	68/67	69/69
Dimension / Net weight	HxWxD	622x824x298/37	622x824x298/37	795x875x320/61	795x875x320/61
Refrigerant (R32) / CO <sub>2</sub> Eq.	kg / T	0,9/0,608	0,9/0,608	1,27/0,857	1,27/0,857
Pipe diameter	Liquid / Gas	Inch [mm]	1/4 [6,35] / 1/2 [12,70]	1/4 [6,35] / 1/2 [12,70]	1/4 [6,35] / 5/8 [15,88]
Pipe length range / Elevation difference (in/out)	m / m	3 ~ 25/20	3 ~ 25/20	3 ~ 50/30	3 ~ 50/30
Pipe length for additional gas / Additional gas amount	m / g/m	10/20	10/20	10/25	10/25
Operation range	Outdoor ambient	°C	-20 ~ +35	-20 ~ +35	-20 ~ +35
Water outlet	Heat / Cool	°C	20 ~ 60/5 ~ 20	20 ~ 60/5 ~ 20	20 ~ 60/5 ~ 20

### Accessories

<b>PAW-ADC-PREKIT-1</b>	Piping pre installation kit for J Generation
<b>PAW-ADC-CV150</b>	Decorative magnetic side cover
<b>CZ-TAW1</b>	Aquarea Smart Cloud for remote control and maintenance through wireless or wired LAN

### Accessories

<b>CZ-NS4P</b>	Additional functions PCB
<b>PAW-A2W-RTWIRED</b>	Room thermostat
<b>PAW-A2W-RTWIREDLESS</b>	Wireless LCD room thermostat

1) Scale from A+++ to D. 2) Scale from A+ to F. 3) Sound power in accordance to 8112013,81312013 and EN12102-1:2017 at +7 °C.

EER and COP calculation is based in accordance to EN14511.

This product is designed to comply with the European Water Quality Directive 98/83/EC amended by 2015/1787/EU. The lifespan of the product is not guaranteed in the case of the use of groundwater, such as spring water or well water, the use of tap water when salt or other impurities are contained, nor in areas of acidic water quality. Maintenance and warranty costs related to these cases are the customer's responsibility.



-23 °C OUTDOOR TEMPERATURE: After cut-off at -23 °C compressor restarts at -20 °C. INTERNET CONTROL: Optional.

GOOD DESIGN AWARD 2017: Indoor units All in One and Bi-bloc J and H Generation awarded with the prestigious Good Design Award 2017.

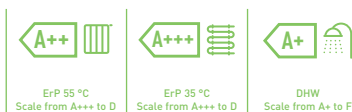

NEW  
2020

**CZ-TAW1**  
Cloud connection.  
For user control and  
installer remote  
maintenance.

## New Aquaarea High Performance All in One Compact J Generation Single Phase. Heating and Cooling • R32 refrigerant

			Single Phase (Power to indoor)			
Kit			KIT-ADC03JE5C	KIT-ADC05JE5C	KIT-ADC07JE5C	KIT-ADC09JE5C-1
Heating capacity / COP (A +7 °C, W 35 °C)	kW / COP		3,20/5,33	5,00/5,00	7,00/4,76	9,00/4,48
Heating capacity / COP (A +7 °C, W 55 °C)	kW / COP		3,20/2,81	5,00/2,72	7,00/2,82	8,95/2,78
Heating capacity / COP (A +2 °C, W 35 °C)	kW / COP		3,20/3,64	4,20/3,18	6,85/3,41	7,00/3,40
Heating capacity / COP (A +2 °C, W 55 °C)	kW / COP		3,20/2,19	4,10/1,99	6,20/2,21	6,30/2,16
Heating capacity / COP (A -7 °C, W 35 °C)	kW / COP		3,30/2,80	4,20/2,59	5,60/2,87	6,12/2,78
Heating capacity / COP (A -7 °C, W 55 °C)	kW / COP		3,20/1,79	3,55/1,71	5,25/1,94	5,90/1,93
Cooling capacity / EER (A 35 °C, W 7 °C)	kW / EER		3,20/3,52	4,50/3,00	6,70/3,03	8,20/2,72
Cooling capacity / EER (A 35 °C, W 18 °C)	kW / EER		3,20/4,85	4,80/4,29	6,70/4,72	9,00/4,18
Seasonal energy efficiency - Heating average climate (W35 °C / W55 °C)	ηs %		200/136	200/136	193/130	193/130
	SCOP		5,07/3,47	5,07/3,47	4,90/3,32	4,90/3,32
Energy class heating average climate (W35 °C / W55 °C) <sup>1)</sup>	A+++ to D		A+++ / A++	A+++ / A++	A+++ / A++	A+++ / A++
<b>Indoor unit</b>			<b>WH-ADC0309J3E5C</b>	<b>WH-ADC0309J3E5C</b>	<b>WH-ADC0309J3E5C</b>	<b>WH-ADC0309J3E5C</b>
Sound pressure	Heat / Cool	dB(A)	28/28	28/28	28/28	28/28
Dimension	HxWxD	mm	1640x598x600	1640x598x600	1640x598x600	1640x598x600
Net weight		kg	101	101	101	101
Water pipe connector		Inch	R 1½	R 1½	R 1½	R 1½
A class pump	Number of speeds		Variable Speed	Variable Speed	Variable Speed	Variable Speed
	Input power (Min/Max)	W	30/120	30/120	30/120	30/120
Heating water flow (ΔT=5 K, 35 °C)		L/min	9,20	14,30	20,10	25,80
Capacity of integrated electric heater		kW	3,00	3,00	3,00	3,00
Power supply 1		A	12,0	12,0	15,9	15,9
Power supply 2		A	13,0	13,0	13,0	13,0
Recommended cable size, supply 1 / 2		mm <sup>2</sup>	3x 1,5/3x 1,5	3x 1,5/3x 1,5	3x 2,5/3x 1,5	3x 2,5/3x 1,5
Water volume		L	185	185	185	185
Maximum water temperature		°C	65	65	65	65
Material inside tank			Stainless steel	Stainless steel	Stainless steel	Stainless steel
Tapping profile according EN16147			L	L	L	L
DHW tank ErP average climate efficiency rating <sup>2)</sup>	A+ to F		A+	A+	A+	A+
DHW tank ErP average climate η / SCOP	ηwh % / SCOP		128/3,20	128/3,20	116/2,90	116/2,90
<b>Outdoor unit</b>			<b>WH-UD03JE5</b>	<b>WH-UD05JE5</b>	<b>WH-UD07JE5</b>	<b>WH-UD09JE5-1</b>
Sound power part load <sup>3)</sup>	Heat	dB(A)	55	55	59	59
Sound power full load	Heat / Cool	dB(A)	60/61	64/64	68/67	69/69
Dimension / Net weight	HxWxD	mm / kg	622x824x298/37	622x824x298/37	795x875x320/61	795x875x320/61
Refrigerant (R32) / CO <sub>2</sub> Eq.		kg / T	0,9/0,608	0,9/0,608	1,27/0,857	1,27/0,857
Pipe diameter	Liquid / Gas	Inch (mm)	1/4 (6,35) / 1/2 (12,70)	1/4 (6,35) / 1/2 (12,70)	1/4 (6,35) / 5/8 (15,88)	1/4 (6,35) / 5/8 (15,88)
Pipe length range / Elevation difference (in/out)		m / m	3-25/20	3-25/20	3-50/30	3-50/30
Pipe length for additional gas / Additional gas amount		m / g/m	10/20	10/20	10/25	10/25
Operation range	Outdoor ambient	°C	-20 ~ +35	-20 ~ +35	-20 ~ +35	-20 ~ +35
Water outlet	Heat / Cool	°C	20 ~ 60/5 ~ 20	20 ~ 60/5 ~ 20	20 ~ 60/5 ~ 20	20 ~ 60/5 ~ 20

### Accessories

<b>CZ-TAW1</b>	Aquaarea Smart Cloud for remote control and maintenance through wireless or wired LAN
<b>CZ-NS4P</b>	Additional functions PCB

### Accessories

<b>PAW-A2W-RTWIRED</b>	Room thermostat
<b>PAW-A2W-RTWIRELESS</b>	Wireless LCD room thermostat

1) Scale from A+++ to D. 2) Scale from A+ to F. 3) Sound power in accordance to 8112013,81312013 and EN12102-1:2017 at +7 °C.

EER and COP calculation is based in accordance to EN14511. \* Available in Autumn 2020.

This product is designed to comply with the European Water Quality Directive 98/83/EC amended by 2015/1787/EU. The lifespan of the product is not guaranteed in the case of the use of groundwater, such as spring water or well water, the use of tap water when salt or other impurities are contained, nor in areas of acidic water quality. Maintenance and warranty costs related to these cases are the customer's responsibility.



-23 °C OUTDOOR TEMPERATURE: After cut-off at -23 °C compressor restarts at -20 °C. INTERNET CONTROL: Optional.

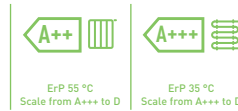

GOOD DESIGN

 011-1W0207  
 011-1W0208  
 011-1W0209

**CZ-TAW1**  
 Cloud connection.  
 For user control and  
 installer remote  
 maintenance.

## Aquarea High Performance Bi-bloc J Generation Single Phase. Heating and Cooling - SDC • R32 refrigerant

			Single Phase (Power to indoor)			
Kit			KIT-WC03J3E5	KIT-WC05J3E5	KIT-WC07J3E5	KIT-WC09J3E5
Heating capacity / COP (A +7 °C, W 35 °C)	kW / COP		3,20/5,33	5,00/5,00	7,00/4,76	9,00/4,48
Heating capacity / COP (A +7 °C, W 55 °C)	kW / COP		3,20/2,81	5,00/2,72	7,00/2,82	8,95/2,78
Heating capacity / COP (A +2 °C, W 35 °C)	kW / COP		3,20/3,64	4,20/3,18	6,85/3,41	7,00/3,40
Heating capacity / COP (A +2 °C, W 55 °C)	kW / COP		3,20/2,19	4,10/1,99	6,20/2,21	6,30/2,16
Heating capacity / COP (A -7 °C, W 35 °C)	kW / COP		3,30/2,80	4,20/2,59	5,60/2,87	6,12/2,78
Heating capacity / COP (A -7 °C, W 55 °C)	kW / COP		3,20/1,79	3,55/1,71	5,25/1,94	5,90/1,93
Cooling capacity / EER (A 35 °C, W 7 °C)	kW / EER		3,20/3,52	4,50/3,00	6,70/3,03	8,20/2,72
Cooling capacity / EER (A 35 °C, W 18 °C)	kW / EER		3,20/4,85	4,80/4,29	6,70/4,72	9,00/4,18
Seasonal energy efficiency - Heating average climate (W35 °C / W55 °C)	ηs %		200/136	200/136	193/130	193/130
	SCOP		5,07/3,47	5,07/3,47	4,90/3,32	4,90/3,32
Energy class heating average climate (W35 °C / W55 °C)	A+++ to D		A+++ / A++	A+++ / A++	A+++ / A++	A+++ / A++
<b>Indoor unit</b>			<b>WH-SDC0305J3E5</b>	<b>WH-SDC0305J3E5</b>	<b>WH-SDC0709J3E5</b>	<b>WH-SDC0709J3E5</b>
Sound pressure	Heat / Cool	dB(A)	28/28	28/28	30/30	30/31
Dimension	HxWxD	mm	892x500x340	892x500x340	892x500x340	892x500x340
Net weight		kg	42	42	42	42
Water pipe connector		Inch	R 1½	R 1½	R 1½	R 1½
A class pump	Number of speeds		Variable Speed	Variable Speed	Variable Speed	Variable Speed
	Input power (Min/Max)	W	30/100	33/106	34/114	40/120
Heating water flow [ΔT=5 K, 35 °C]		L/min	9,2	14,3	20,1	25,8
Capacity of integrated electric heater		kW	3	3	3	3
Power supply 1		A	12,0	12,0	15,9	15,9
Power supply 2		A	13,0	13,0	13,0	13,0
Recommended cable size, supply 1 / 2		mm²	3x1,5/3x1,5	3x1,5/3x1,5	3x2,5/3x1,5	3x2,5/3x1,5
<b>Outdoor unit</b>			<b>WH-UD03JE5</b>	<b>WH-UD05JE5</b>	<b>WH-UD07JE5</b>	<b>WH-UD09JE5-1</b>
Sound power part load <sup>1)</sup>	Heat	dB(A)	55	55	59	59
Sound power full load	Heat / Cool	dB(A)	60/61	64/64	68/67	69/69
Dimension	HxWxD	mm	622x824x298	622x824x298	795x875x320	795x875x320
Net weight		kg	37	37	61	61
Refrigerant (R32) / CO <sub>2</sub> Eq.		kg / T	0,9/0,608	0,9/0,608	1,27/0,857	1,27/0,857
Pipe diameter	Liquid / Gas	Inch (mm)	1/4 (6,35)/1/2 (12,70)	1/4 (6,35)/1/2 (12,70)	1/4 (6,35)/5/8 (15,88)	1/4 (6,35)/5/8 (15,88)
Pipe length range		m	3-25	3-25	3-50	3-50
Elevation difference (in/out)		m	20	20	30	30
Pipe length for additional gas		m	10	10	10	10
Additional gas amount		g/m	20	20	25	25
Operation range	Outdoor ambient	°C	-20~+35	-20~+35	-20~+35	-20~+35
Water outlet	Heat / Cool	°C	20~60/5~20	20~60/5~20	20~60/5~20	20~60/5~20

### Accessories

<b>PAW-TD20C1E5</b>	Tank 200L - Stainless steel
<b>PAW-TD30C1E5</b>	Tank 300L - Stainless steel
<b>PAW-TA20C1E5STD</b>	Tank 200L - Enamelled
<b>PAW-TA30C1E5STD</b>	Tank 300L - Enamelled
<b>PAW-3WYVLV-HW</b>	3 way valve for DHW Tanks
<b>CZ-NV1</b>	3 way valve kit for inside the hydrokit

### Accessories

<b>PAW-BTANK50L-2</b>	Buffer tank 50L
<b>CZ-TAW1</b>	Aquarea Smart Cloud for remote control and maintenance through wireless or wired LAN
<b>CZ-NS4P</b>	Additional functions PCB
<b>PAW-A2W-RTWIRED</b>	Room thermostat
<b>PAW-A2W-RTWIRELESS</b>	Wireless LCD room thermostat

1) Sound power in accordance to 8112013,81312013 and EN12102-1:2017 at +7 °C. EER and COP calculation is based in accordance to EN14511.



-23 °C OUTDOOR TEMPERATURE: After cut-off at -23 °C compressor restarts at -20 °C. INTERNET CONTROL: Optional.  
 GOOD DESIGN AWARD 2017: Indoor units All in One and Bi-bloc J and H Generation awarded with the prestigious Good Design Award 2017.

NEW  
2020

**CZ-TAW1**  
Cloud connection.  
For user control and  
installer remote  
maintenance.

## New Aquarea High Performance Mono-bloc J Generation Single Phase. Heating and Cooling - MDC • R32 refrigerant

Outdoor unit		Single Phase		
		WH-MDC05J3E5	WH-MDC07J3E5	WH-MDC09J3E5
Heating capacity / COP (A +7 °C, W 35 °C)	kW / COP	5,00/5,08	7,00/4,76	9,00/4,48
Heating capacity / COP (A +7 °C, W 55 °C)	kW / COP	5,00/3,01	7,00/2,82	8,95/2,78
Heating capacity / COP (A +2 °C, W 35 °C)	kW / COP	5,00/3,57	7,00/3,40	7,45/3,13
Heating capacity / COP (A +2 °C, W 55 °C)	kW / COP	5,00/2,27	6,30/2,16	7,00/2,12
Heating capacity / COP (A -7 °C, W 35 °C)	kW / COP	5,00/2,78	6,80/2,81	7,50/2,63
Heating capacity / COP (A -7 °C, W 55 °C)	kW / COP	5,00/1,85	6,30/1,86	7,00/1,80
Cooling capacity / EER (A 35 °C, W 7 °C)	kW / EER	5,00/3,31	7,00/3,06	9,00/2,71
Cooling capacity / EER (A 35 °C, W 18 °C)	kW / EER	5,00/5,05	7,00/4,73	9,00/4,25
Seasonal energy efficiency - Heating average climate (W35 °C / W55 °C)	ηs %	202/142	193/130	193/130
	SCOP	5,12/3,63	4,90/3,32	4,90/3,32
Energy class heating average climate (W35 °C / W55 °C)	A+++ to D	A+++/A++	A+++/A++	A+++/A++
Sound power part load <sup>1)</sup>	Heat	dB(A)	59	59
Sound power full load	Heat / Cool	dB(A)	64/65	69/68
Dimension	HxWxD	mm	865 x 1283 x 320	865 x 1283 x 320
Net weight		kg	99	104
Refrigerant (R32) / CO <sub>2</sub> Eq. <sup>2)</sup>		kg / T	1,3/0,878	1,3/0,878
Water pipe connector		Inch	R 1½	R 1½
Pump	Number of speeds		Variable Speed	Variable Speed
	Input power (Min/Max)	W	34/96	36/100
Heating water flow (ΔT=5 K, 35 °C)		L/min	14,3	20,1
Capacity of integrated electric heater		kW	3	3
Input Power	Heat	kW	0,985	1,47
	Cool	kW	1,51	2,29
Running and Starting current	Heat	A	4,7	7,0
	Cool	A	7,0	10,5
Power supply 1		A	12	17
Power supply 2		A	13	13
Recommended cable size, supply 1 / 2		mm <sup>2</sup>	3x1,5/3x1,5	3x2,5/3x1,5
Operation range (outdoor temperature)	Heat	°C	-20 ~ 35	-20 ~ 35
	Cool	°C	10 ~ 43	10 ~ 43
Water outlet	Heat	°C	20 ~ 60	20 ~ 60
	Cool	°C	5 ~ 20	5 ~ 20

### Accessories

<b>PAW-TD20C1E5</b>	Tank 200L - Stainless steel
<b>PAW-TD30C1E5</b>	Tank 300L - Stainless steel
<b>PAW-TA20C1E5STD</b>	Tank 200L - Enamelled
<b>PAW-TA30C1E5STD</b>	Tank 300L - Enamelled
<b>PAW-TD20B8E3-1</b>	Combo Tank 185L + 80L - Enamelled
<b>PAW-TD23B6E5</b>	Combo Tank 230L + 60L - Stainless Steel

### Accessories

<b>PAW-3WYVLV-HW</b>	3 way valve for DHW Tanks
<b>PAW-BTANK50L-2</b>	Buffer tank 50L
<b>CZ-TAW1</b>	Aquarea Smart Cloud for remote control and maintenance through wireless or wired LAN
<b>PAW-A2W-RTWIRED</b>	Room thermostat
<b>PAW-A2W-RTWIRELESS</b>	Wireless LCD room thermostat

1) Sound power in accordance to 8112013,81312013 and EN12102-1:2017 at +7 °C. 2) WH-MDC models are hermetically sealed. EER and COP calculation is based in accordance to EN14511. \* Available in May 2020.



-23 °C OUTDOOR TEMPERATURE: After cut-off at -23 °C compressor restarts at -20 °C. INTERNET CONTROL: Optional.

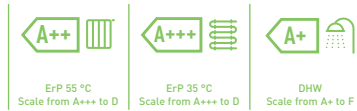

**CZ-TAW1**  
Cloud connection.  
For user control and  
installer remote  
maintenance.

## Aquarea High Performance All in One H Generation Single Phase. Heating and Cooling 1 or 2 zones • R410A refrigerant

		Single Phase (Power to indoor)			
Kit 1 zone (for 2 zone add B at the end)		KIT-ADC03HE5	KIT-ADC05HE5	KIT-ADC07HE5	KIT-ADC09HE5
Heating capacity / COP (A +7 °C, W 35 °C)	kW / COP	3,20/5,00	5,00/4,63	7,00/4,46	9,00/4,13
Heating capacity / COP (A +7 °C, W 55 °C)	kW / COP	3,20/2,67	5,00/2,65	6,80/2,63	8,90/2,41
Heating capacity / COP (A +2 °C, W 35 °C)	kW / COP	3,20/3,56	4,20/3,11	6,55/3,34	6,70/3,13
Heating capacity / COP (A +2 °C, W 55 °C)	kW / COP	3,20/2,15	4,10/1,98	6,00/1,99	6,00/1,99
Heating capacity / COP (A -7 °C, W 35 °C)	kW / COP	3,20/2,69	4,20/2,59	5,15/2,68	5,90/2,52
Heating capacity / COP (A -7 °C, W 55 °C)	kW / COP	3,20/1,72	3,55/1,71	4,80/1,89	5,80/1,88
Cooling capacity / EER (A 35 °C, W 7 °C)	kW / EER	3,20/3,08	4,50/2,69	6,00/2,63	7,00/2,43
Cooling capacity / EER (A 35 °C, W 18 °C)	kW / EER	3,30/3,75	5,00/3,76	6,00/3,57	7,00/3,26
Seasonal energy efficiency - Heating average climate (W35 °C / W55 °C)	ηs %	195/130	195/130	190/130	190/130
	SCOP	4,95/3,33	4,95/3,33	4,83/3,33	4,83/3,33
Energy class heating average climate (W35 °C / W55 °C) <sup>1)</sup>	A+++ to D	A+++ / A++	A+++ / A++	A+++ / A++	A+++ / A++
<b>Indoor unit 1 zone hydrokit</b>		<b>WH-ADC0309H3E5</b>	<b>WH-ADC0309H3E5</b>	<b>WH-ADC0309H3E5</b>	<b>WH-ADC0309H3E5</b>
<b>Indoor unit 2 zones built-in hydrokit</b>		<b>WH-ADC0309H3E5B</b>	<b>WH-ADC0309H3E5B</b>	<b>WH-ADC0309H3E5B</b>	<b>WH-ADC0309H3E5B</b>
Sound pressure	Heat / Cool	28/28	28/28	28/28	28/28
Dimension / Net weight	HxWxD	1800x598x717/124	1800x598x717/124	1800x598x717/124	1800x598x717/124
Water pipe connector		R 1½	R 1½	R 1½	R 1½
A class pump	Number of speeds	Variable Speed	Variable Speed	Variable Speed	Variable Speed
	Input power (Min/Max)	W	30/120	30/120	30/120
Heating water flow [ΔT=5 K, 35 °C]		L/min	9,2	14,3	20,1
Capacity of integrated electric heater		kW	3	3	3
Power supply 1		A	12,0	12,0	21,0
Power supply 2		A	13,0	13,0	13,0
Recommended cable size, supply 1 / 2		mm <sup>2</sup>	3x1,5/3x1,5	3x1,5/3x1,5	3x2,5/3x1,5
Water volume		L	185	185	185
Maximum water temperature		°C	65	65	65
Material inside tank		Stainless steel	Stainless steel	Stainless steel	Stainless steel
Tapping profile according EN16147		L	L	L	L
DHW tank ErP average climate efficiency rating <sup>2)</sup>		A+	A+	A	A
DHW tank ErP average climate η / SCOP		ηwh % / SCOP	120/3,00	120/3,00	113/2,83
<b>Outdoor unit</b>		<b>WH-UD03HE5-1</b>	<b>WH-UD05HE5-1</b>	<b>WH-UD07HE5-1</b>	<b>WH-UD09HE5-1</b>
Sound power part load <sup>3)</sup>	Heat	dB(A)	55	55	59
Sound power full load	Heat / Cool	dB(A)	64/65	65/66	68/66
Dimension / Net weight	HxWxD	mm / kg	622x824x298/39	622x824x298/39	795x900x320/66
Refrigerant (R410A) / CO <sub>2</sub> Eq.		kg / T	1,20/2,506	1,20/2,506	1,45/3,028
Pipe diameter	Liquid / Gas	Inch (mm)	1/4 (6,35)/1/2 (12,70)	1/4 (6,35)/1/2 (12,70)	1/4 (6,35)/5/8 (15,88)
Pipe length range / Elevation difference (in/out)		m / m	3-15/5	3-15/5	3-40/30
Pipe length for additional gas / Additional gas amount		m / g/m	10/20	10/20	10/30
Operation range	Outdoor ambient	°C	-20~+35	-20~+35	-20~+35
Water outlet	Heat / Cool	°C	20~55/5~20	20~55/5~20	20~55/5~20

### Accessories

<b>PAW-ADC-PREKIT-H</b>	Piping pre installation kit for H Generation
<b>PAW-ADC-CV150</b>	Decorative magnetic side cover
<b>CZ-TAW1</b>	Aquarea Smart Cloud for remote control and maintenance through wireless or wired LAN

### Accessories

<b>CZ-NS4P</b>	Additional functions PCB
<b>PAW-A2W-RTWIRED</b>	Room thermostat
<b>PAW-A2W-RTWIRELESS</b>	Wireless LCD room thermostat

1) Scale from A+++ to D. 2) Scale from A+ to F. 3) Sound power in accordance to 8112013,81312013 and EN12102-1:2017 at +7 °C.

EER and COP calculation is based in accordance to EN14511.

This product is designed to comply with the European Water Quality Directive 98/83/EC amended by 2015/1787/EU. The lifespan of the product is not guaranteed in the case of the use of groundwater, such as spring water or well water, the use of tap water when salt or other impurities are contained, nor in areas of acidic water quality. Maintenance and warranty costs related to these cases are the customer's responsibility.



-23 °C OUTDOOR TEMPERATURE: After cut-off at -23 °C compressor restarts at -20 °C. INTERNET CONTROL: Optional.  
GOOD DESIGN AWARD 2017: Indoor units All in One and Bi-bloc J and H Generation awarded with the prestigious Good Design Award 2017.

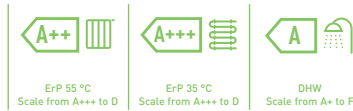

**CZ-TAW1**  
Cloud connection.  
For user control and  
installer remote  
maintenance.

## Aquaarea High Performance All in One H Generation Single Phase / Three Phase. Heating and Cooling • R410A refrigerant

Kit	Single Phase (Power to indoor)			Three Phase (Power to indoor)			
	KIT-ADC12HE5	KIT-ADC16HE5	KIT-ADC09HE8	KIT-ADC12HE8	KIT-ADC16HE8		
Heating capacity / COP (A +7 °C, W 35 °C)	kW / COP	12,00/4,74	16,00/4,28	9,00/4,84	12,00/4,74	16,00/4,28	
Heating capacity / COP (A +7 °C, W 55 °C)	kW / COP	12,00/2,88	14,50/2,68	9,00/2,94	12,00/2,88	14,50/2,68	
Heating capacity / COP (A +2 °C, W 35 °C)	kW / COP	11,40/3,44	13,00/3,28	9,00/3,59	11,40/3,44	13,00/3,28	
Heating capacity / COP (A +2 °C, W 55 °C)	kW / COP	9,10/2,20	9,80/2,17	8,80/2,23	9,10/2,20	9,80/2,17	
Heating capacity / COP (A -7 °C, W 35 °C)	kW / COP	10,00/2,73	11,40/2,57	9,00/2,85	10,00/2,73	11,40/2,57	
Heating capacity / COP (A -7 °C, W 55 °C)	kW / COP	8,20/1,92	9,00/1,82	7,90/2,05	8,20/1,92	9,00/1,82	
Cooling capacity / EER (A 35 °C, W 7 °C)	kW / EER	10,00/2,81	12,20/2,56	7,00/3,17	10,00/2,85	12,20/2,56	
Cooling capacity / EER (A 35 °C, W 18 °C)	kW / EER	10,00/4,17	12,20/4,12	7,00/4,61	10,00/4,17	12,20/4,12	
Seasonal energy efficiency - Heating average climate (W35 °C / W55 °C)	ηs %	190/134	190/130	190/133	190/134	190/130	
Energy class heating average climate (W35 °C / W55 °C) <sup>1)</sup>	A+++ to D	A+++ / A++	A+++ / A++	A+++ / A++	A+++ / A++	A+++ / A++	
<b>Indoor unit</b>		<b>WH-ADC1216H6E5</b>	<b>WH-ADC1216H6E5</b>	<b>WH-ADC0916H9E8</b>	<b>WH-ADC0916H9E8</b>	<b>WH-ADC0916H9E8</b>	
Sound pressure	Heat / Cool	dB(A)		dB(A)		dB(A)	
Dimension / Net weight	HxWxD	mm / kg		mm / kg		mm / kg	
Water pipe connector		Inch		Inch		Inch	
A class pump	Number of speeds	Variable Speed		Variable Speed		Variable Speed	
	Input power (Min/Max)	W		W		W	
Heating water flow (ΔT=5 K, 35 °C)	L/min	34,4		45,9		25,8	
Capacity of integrated electric heater	kW	6		6		9	
Power supply 1	A	24,0		26,0		8,8	
Power supply 2	A	26,0		26,0		13,0	
Recommended cable size, supply 1 / 2	mm <sup>2</sup>	3x4,0/3x4,0		3x4,0/3x4,0		5x1,5/5x1,5	
Water volume	L	185		185		185	
Maximum water temperature	°C	65		65		65	
Material inside tank		Stainless steel		Stainless steel		Stainless steel	
Tapping profile according EN16147		L		L		L	
DHW tank ErP average climate efficiency rating <sup>2)</sup>	A+ to F	A		A		A	
DHW tank ErP average climate η / SCOP	ηwh % / SCOP	95/2,38		91/2,28		95/2,38	
<b>Outdoor unit</b>		<b>WH-UD12HE5</b>	<b>WH-UD16HE5</b>	<b>WH-UD09HE8</b>	<b>WH-UD12HE8</b>	<b>WH-UD16HE8</b>	
Sound power part load <sup>3)</sup>	Heat	dB(A)		dB(A)		dB(A)	
Sound power full load	Heat / Cool	dB(A)		dB(A)		dB(A)	
Dimension / Net weight	HxWxD	mm / kg		mm / kg		mm / kg	
Refrigerant (R410A) / CO <sub>2</sub> Eq.	kg / T	2,55/5,324		2,55/5,324		2,55/5,324	
Pipe diameter	Liquid / Gas	Inch (mm)		Inch (mm)		Inch (mm)	
Pipe length range / Elevation difference (in/out)	m / m	3-50/30		3-50/30		3-30/20	
Pipe length for additional gas / Additional gas amount	m / g/m	10/50		10/50		10/50	
Operation range	Outdoor ambient	°C		°C		°C	
Water outlet	Heat / Cool	°C		°C		°C	

### Accessories

<b>PAW-ADC-PREKIT-H</b>	Piping pre installation kit for H Generation
<b>PAW-ADC-CV150</b>	Decorative magnetic side cover
<b>CZ-TAW1</b>	Aquaarea Smart Cloud for remote control and maintenance through wireless or wired LAN

### Accessories

<b>CZ-NS4P</b>	Additional functions PCB
<b>PAW-A2W-RTWIRED</b>	Room thermostat
<b>PAW-A2W-RTWIREDLESS</b>	Wireless LCD room thermostat

1) Scale from A+++ to D. 2) Scale from A+ to F. 3) Sound power in accordance to 8112013,81312013 and EN12102-1:2017 at +7 °C.

EER and COP calculation is based in accordance to EN14511.

This product is designed to comply with the European Water Quality Directive 98/83/EC amended by 2015/1787/EU. The lifespan of the product is not guaranteed in the case of the use of groundwater, such as spring water or well water, the use of tap water when salt or other impurities are contained, nor in areas of acidic water quality. Maintenance and warranty costs related to these cases are the customer's responsibility.



-23 °C OUTDOOR TEMPERATURE: After cut-off at -23 °C compressor restarts at -20 °C. INTERNET CONTROL: Optional.

GOOD DESIGN AWARD 2017: Indoor units All in One and Bi-bloc J and H Generation awarded with the prestigious Good Design Award 2017.

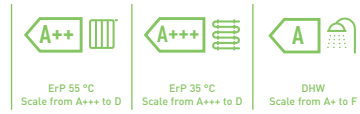

**CZ-TAW1**  
Cloud connection.  
For user control and  
installer remote  
maintenance.

## Aquarea T-CAP All in One H Generation Single Phase / Three Phase. Heating and Cooling • R410A refrigerant

Kit	Single Phase (Power to indoor)			Three Phase (Power to indoor)		
	KIT-AXC09HE5	KIT-AXC12HE5	KIT-AXC09HE8	KIT-AXC12HE8	KIT-AXC16HE8	
Heating capacity / COP [A +7 °C, W 35 °C]	kW / COP	9,00/4,84	12,00/4,74	9,00/4,84	12,00/4,74	16,00/4,28
Heating capacity / COP [A +7 °C, W 55 °C]	kW / COP	9,00/2,94	12,00/2,88	9,00/2,94	12,00/2,88	16,00/2,71
Heating capacity / COP [A +2 °C, W 35 °C]	kW / COP	9,00/3,59	12,00/3,44	9,00/3,59	12,00/3,44	16,00/3,10
Heating capacity / COP [A +2 °C, W 55 °C]	kW / COP	9,00/2,21	12,00/2,19	9,00/2,21	12,00/2,19	16,00/2,13
Heating capacity / COP [A -7 °C, W 35 °C]	kW / COP	9,00/2,85	12,00/2,72	9,00/2,85	12,00/2,72	16,00/2,49
Heating capacity / COP [A -7 °C, W 55 °C]	kW / COP	9,00/2,02	12,00/1,92	9,00/2,02	12,00/1,92	16,00/1,86
Cooling capacity / EER [A 35 °C, W 7 °C]	kW / EER	7,00/3,17	10,00/2,81	7,00/3,17	10,00/2,81	12,20/2,57
Cooling capacity / EER [A 35 °C, W 18 °C]	kW / EER	7,00/5,19	10,00/5,13	7,00/5,19	10,00/5,13	12,20/3,49
Seasonal energy efficiency - Heating average climate [W35 °C / W55 °C]	ηs %	181/130	170/130	181/130	170/130	160/125
Energy class heating average climate [W35 °C / W55 °C] <sup>1)</sup>	SCOP	4,60/3,33	4,33/3,33	4,60/3,33	4,33/3,33	4,08/3,20
Energy class heating average climate [W35 °C / W55 °C] <sup>1)</sup>	A+++ to D	A+++ / A++	A++ / A++	A+++ / A++	A++ / A++	A++ / A++
<b>Indoor unit</b>		<b>WH-ADC1216H6E5</b>	<b>WH-ADC1216H6E5</b>	<b>WH-ADC0916H9E8</b>	<b>WH-ADC0916H9E8</b>	<b>WH-ADC0916H9E8</b>
Sound pressure	Heat / Cool	dB(A)		33/33	33/33	33/33
Dimension / Net weight	HxWxD	mm / kg		1800x598x717/124	1800x598x717/124	1800x598x717/126
Water pipe connector		Inch		R 1¼	R 1¼	R 1¼
A class pump	Number of speeds	Variable Speed		Variable Speed	Variable Speed	Variable Speed
	Input power (Min/Max)	W		36/152	36/152	36/152
Heating water flow [ΔT=5 K, 35 °C]		L/min		25,8	34,4	45,9
Capacity of integrated electric heater		kW		6	6	9
Power supply 1		A		29,0	29,0	10,4
Power supply 2		A		26,0	26,0	13,0
Recommended cable size, supply 1 / 2		mm²		3x4,0/3x4,0	3x4,0/3x4,0	5x1,5/5x1,5
Water volume		L		185	185	185
Maximum water temperature		°C		65	65	65
Material inside tank		Stainless steel		Stainless steel	Stainless steel	Stainless steel
Tapping profile according EN16147		L		L	L	L
DHW tank ErP average climate efficiency rating <sup>2)</sup>		A		A	A	A
DHW tank ErP average climate η / SCOP	ηwh % / SCOP	95/2,38		95/2,38	95/2,38	91/2,28
<b>Outdoor unit</b>		<b>WH-UX09HE5</b>	<b>WH-UX12HE5</b>	<b>WH-UX09HE8</b>	<b>WH-UX12HE8</b>	<b>WH-UX16HE8</b>
Sound power part load <sup>3)</sup>	Heat	dB(A)		66	66	65
Sound power full load	Heat / Cool	dB(A)		68/67	69/68	68/67
Dimension / Net weight	HxWxD	mm / kg		1340x900x320/101	1340x900x320/101	1340x900x320/108
Refrigerant [R410A] / CO <sub>2</sub> Eq.		kg / T		2,85/5,951	2,85/5,951	2,85/5,951
Pipe diameter	Liquid / Gas	Inch (mm)		3/8(9,52)/5/8(15,88)	3/8(9,52)/5/8(15,88)	3/8(9,52)/5/8(15,88)
Pipe length range / Elevation difference (in/out)		m / m		3~30/20	3~30/20	3~30/20
Pipe length for additional gas / Additional gas amount		m / g/m		10/50	10/50	10/50
Operation range	Outdoor ambient	°C		-28~+35	-28~+35	-28~+35
Water outlet	Heat / Cool	°C		20~60/5~20	20~60/5~20	20~60/5~20

### Accessories

<b>PAW-ADC-PREKIT-H</b>	Piping pre installation kit for H Generation
<b>PAW-ADC-CV150</b>	Decorative magnetic side cover
<b>CZ-TAW1</b>	Aquarea Smart Cloud for remote control and maintenance through wireless or wired LAN

### Accessories

<b>CZ-NS4P</b>	Additional functions PCB
<b>PAW-A2W-RTWIRED</b>	Room thermostat
<b>PAW-A2W-RTWIRELESS</b>	Wireless LCD room thermostat

1) Scale from A+++ to D. 2) Scale from A+ to F. 3) Sound power in accordance to 8112013,81312013 and EN12102-1:2017 at +7 °C.

EER and COP calculation is based in accordance to EN14511.

This product is designed to comply with the European Water Quality Directive 98/83/EC amended by 2015/1787/EU. The lifespan of the product is not guaranteed in the case of the use of groundwater, such as spring water or well water, the use of tap water when salt or other impurities are contained, nor in areas of acidic water quality. Maintenance and warranty costs related to these cases are the customer's responsibility.



INTERNET CONTROL: Optional.

GOOD DESIGN AWARD 2017: Indoor units All in One and Bi-bloc J and H Generation awarded with the prestigious Good Design Award 2017.

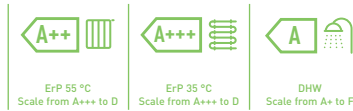
**GOOD DESIGN**

**CZ-TAW1**  
 Cloud connection.  
 For user control and  
 installer remote  
 maintenance.

**Aquaarea T-CAP All in One H Generation Three Phase. Super Quiet outdoor unit. Heating and Cooling • R410A refrigerant**

			Three Phase (Power to indoor)		
Kit			KIT-AQC09HE8	KIT-AQC12HE8	KIT-AQC16HE8
Heating capacity / COP (A +7 °C, W 35 °C)	kW / COP		9,00/4,84	12,00/4,74	16,00/4,28
Heating capacity / COP (A +7 °C, W 55 °C)	kW / COP		9,00/2,94	12,00/2,88	16,00/2,71
Heating capacity / COP (A +2 °C, W 35 °C)	kW / COP		9,00/3,59	12,00/3,44	16,00/3,10
Heating capacity / COP (A +2 °C, W 55 °C)	kW / COP		9,00/2,21	12,00/2,19	16,00/2,13
Heating capacity / COP (A -7 °C, W 35 °C)	kW / COP		9,00/2,85	12,00/2,72	16,00/2,49
Heating capacity / COP (A -7 °C, W 55 °C)	kW / COP		9,00/2,02	12,00/1,92	16,00/1,86
Cooling capacity / EER (A 35 °C, W 7 °C)	kW / EER		7,00/3,17	10,00/2,81	12,20/2,57
Cooling capacity / EER (A 35 °C, W 18 °C)	kW / EER		7,00/5,19	10,00/5,13	12,20/3,49
Seasonal energy efficiency - Heating average climate (W35 °C / W55 °C)	$\eta_s$ %		181/130	170/130	160/125
	SCOP		4,60/3,33	4,33/3,33	4,08/3,20
Energy class heating average climate (W35 °C / W55 °C) <sup>1)</sup>	A+++ to D		A+++ / A++	A++ / A++	A++ / A++
<b>Indoor unit</b>			<b>WH-ADC0916H9E8</b>	<b>WH-ADC0916H9E8</b>	<b>WH-ADC0916H9E8</b>
Sound pressure	Heat / Cool	dB(A)	33/33	33/33	33/33
Dimension / Net weight	HxWxD	mm / kg	1800x598x717/126	1800x598x717/126	1800x598x717/126
Water pipe connector		Inch	R 1½	R 1½	R 1½
A class pump	Number of speeds		Variable Speed	Variable Speed	Variable Speed
	Input power (Min/Max)	W	36/152	36/152	36/152
Heating water flow ( $\Delta T=5$ K, 35 °C)		L/min	25,8	34,4	45,9
Capacity of integrated electric heater		kW	9	9	9
Power supply 1		A	14,7	11,9	15,5
Power supply 2		A	13,0	13,0	13,0
Recommended cable size, supply 1 / 2		mm <sup>2</sup>	5x1,5/5x1,5	5x1,5/5x1,5	5x1,5/5x1,5
Water volume		L	185	185	185
Maximum water temperature		°C	65	65	65
Material inside tank			Stainless steel	Stainless steel	Stainless steel
Tapping profile according EN16147			L	L	L
DHW tank ErP average climate efficiency rating <sup>2)</sup>		A+ to F	A	A	A
DHW tank ErP average climate $\eta$ / SCOP	$\eta_{wh}$ % / SCOP		95/2,38	95/2,38	91/2,28
<b>Outdoor unit</b>			<b>WH-UQ09HE8</b>	<b>WH-UQ12HE8</b>	<b>WH-UQ16HE8</b>
Sound power part load <sup>3)</sup>	Heat	dB(A)	58	58	62
Sound power full load	Heat / Cool	dB(A)	61/63	62/64	65/68
Dimension / Net weight	HxWxD	mm / kg	1410x1283x320/151	1410x1283x320/151	1410x1283x320/161
Refrigerant (R410A) / CO <sub>2</sub> Eq.		kg / T	2,85/5,951	2,85/5,951	2,99/6,243
Pipe diameter	Liquid / Gas	Inch (mm)	3/8(9,52)/5/8(15,88)	3/8(9,52)/5/8(15,88)	3/8(9,52)/5/8(15,88)
Pipe length range / Elevation difference (in/out)		m / m	3-30/20	3-30/20	3-30/20
Pipe length for additional gas / Additional gas amount		m / g/m	10/50	10/50	10/50
Operation range	Outdoor ambient	°C	-28 ~ +35	-28 ~ +35	-28 ~ +35
Water outlet	Heat / Cool	°C	20-60/5-20	20-60/5-20	20-60/5-20

**Accessories**

<b>PAW-ADC-PREKIT-H</b>	Piping pre installation kit for H Generation
<b>PAW-ADC-CV150</b>	Decorative magnetic side cover
<b>CZ-TAW1</b>	Aquaarea Smart Cloud for remote control and maintenance through wireless or wired LAN

**Accessories**

<b>CZ-NS4P</b>	Additional functions PCB
<b>PAW-A2W-RTWIRED</b>	Room thermostat
<b>PAW-A2W-RTWIRELESS</b>	Wireless LCD room thermostat

1) Scale from A+++ to D. 2) Scale from A+ to F. 3) Sound power in accordance to 8112013,81312013 and EN12102-1:2017 at +7 °C.

EER and COP calculation is based in accordance to EN14511.

This product is designed to comply with the European Water Quality Directive 98/83/EC amended by 2015/1787/EU. The lifespan of the product is not guaranteed in the case of the use of groundwater, such as spring water or well water, the use of tap water when salt or other impurities are contained, nor in areas of acidic water quality. Maintenance and warranty costs related to these cases are the customer's responsibility.



INTERNET CONTROL: Optional.

GOOD DESIGN AWARD 2017: Indoor units All in One and Bi-bloc J and H Generation awarded with the prestigious Good Design Award 2017.

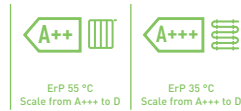
**GOOD DESIGN**

**CZ-TAW1**  
 Cloud connection.  
 For user control and  
 installer remote  
 maintenance.

**Aquarea High Performance Bi-bloc H Generation Single Phase. Heating and Cooling - SDC • R410A refrigerant**

		Single Phase			
Kit		KIT-WC03H3E5	KIT-WC05H3E5	KIT-WC07H3E5	KIT-WC09H3E5
Heating capacity / COP [A +7 °C, W 35 °C]	kW / COP	3,20/5,00	5,00/4,63	7,00/4,46	9,00/4,13
Heating capacity / COP [A +7 °C, W 55 °C]	kW / COP	3,20/2,67	5,00/2,65	6,80/2,63	8,90/2,41
Heating capacity / COP [A +2 °C, W 35 °C]	kW / COP	3,20/3,56	4,20/3,11	6,55/3,34	6,70/3,13
Heating capacity / COP [A +2 °C, W 55 °C]	kW / COP	3,20/2,15	4,10/1,98	6,00/1,99	6,00/1,99
Heating capacity / COP [A -7 °C, W 35 °C]	kW / COP	3,20/2,69	4,20/2,59	5,15/2,68	5,90/2,52
Heating capacity / COP [A -7 °C, W 55 °C]	kW / COP	3,20/1,72	3,55/1,71	4,80/1,89	5,80/1,88
Cooling capacity / EER [A 35 °C, W 7 °C]	kW / EER	3,20/3,08	4,50/2,69	6,00/2,63	7,00/2,43
Cooling capacity / EER [A 35 °C, W 18 °C]	kW / EER	3,30/3,75	5,00/3,76	6,00/3,57	7,00/3,26
Seasonal energy efficiency - Heating average climate [W35 °C / W55 °C]	ηs %	195/130	195/130	190/130	190/130
	SCOP	4,95/3,33	4,95/3,33	4,83/3,33	4,83/3,33
Energy class heating average climate [W35 °C / W55 °C]	A+++ to D	A+++ / A++	A+++ / A++	A+++ / A++	A+++ / A++
<b>Indoor unit</b>		<b>WH-SDC03H3E5-1</b>	<b>WH-SDC05H3E5-1</b>	<b>WH-SDC07H3E5-1</b>	<b>WH-SDC09H3E5-1</b>
Sound pressure	Heat / Cool	28/28	28/28	30/30	30/30
Dimension	HxWxD	892x500x340	892x500x340	892x500x340	892x500x340
Net weight		44	44	44	44
Water pipe connector		R 1½	R 1½	R 1½	R 1½
A class pump	Number of speeds	Variable Speed	Variable Speed	Variable Speed	Variable Speed
	Input power (Min/Max)	W	30/100	33/106	34/114
Heating water flow [ΔT=5 K, 35 °C]		L/min	9,2	14,3	20,1
Capacity of integrated electric heater		kW	3	3	3
Power supply 1		A	12,0	12,0	21,0
Power supply 2		A	13,0	13,0	13,0
Recommended cable size, supply 1 / 2		mm	3x1,5/3x1,5	3x1,5/3x1,5	3x1,5/3x1,5
<b>Outdoor unit</b>		<b>WH-UD03HE5-1</b>	<b>WH-UD05HE5-1</b>	<b>WH-UD07HE5-1</b>	<b>WH-UD09HE5-1</b>
Sound power part load <sup>1)</sup>	Heat	55	55	59	59
Sound power full load	Heat / Cool	64/65	65/66	68/66	69/68
Dimension	HxWxD	622x824x298	622x824x298	795x900x320	795x900x320
Net weight		39	39	66	66
Refrigerant (R410A) / CO <sub>2</sub> Eq.		kg / T	1,20/2,506	1,20/2,506	1,45/3,028
Pipe diameter	Liquid / Gas	Inch (mm)	1/4 (6,35)/1/2 (12,70)	1/4 (6,35)/1/2 (12,70)	1/4 (6,35)/5/8 (15,88)
Pipe length range		m	3~15	3~15	3~40
Elevation difference (in/out)		m	5	5	30
Pipe length for additional gas		m	10	10	10
Additional gas amount		g/m	20	20	30
Operation range	Outdoor ambient	°C	-20~+35	-20~+35	-20~+35
Water outlet	Heat / Cool	°C	20~55/5~20	20~55/5~20	20~55/5~20

**Accessories**

<b>PAW-TD20C1E5</b>	Tank 200L - Stainless steel
<b>PAW-TD30C1E5</b>	Tank 300L - Stainless steel
<b>PAW-TA20C1E5STD</b>	Tank 200L - Enamelled
<b>PAW-TA30C1E5STD</b>	Tank 300L - Enamelled
<b>PAW-3WYVLV-HW</b>	3 way valve for DHW Tanks
<b>CZ-NV1</b>	3 way valve kit for inside the hydrokit

**Accessories**

<b>PAW-BTANK50L-2</b>	Buffer tank 50L
<b>CZ-TAW1</b>	Aquarea Smart Cloud for remote control and maintenance through wireless or wired LAN
<b>CZ-NS4P</b>	Additional functions PCB
<b>PAW-A2W-RTWIRED</b>	Room thermostat
<b>PAW-A2W-RTWIRELESS</b>	Wireless LCD room thermostat

1) Sound power in accordance to 8112013,81312013 and EN12102-1:2017 at +7 °C. EER and COP calculation is based in accordance to EN14511.



-23 °C OUTDOOR TEMPERATURE: After cut-off at -23 °C compressor restarts at -20 °C. INTERNET CONTROL: Optional.  
 GOOD DESIGN AWARD 2017: Indoor units All in One and Bi-bloc J and H Generation awarded with the prestigious Good Design Award 2017.



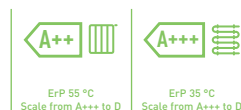

**CZ-TAW1**  
Cloud connection.  
For user control and  
installer remote  
maintenance.

## Aquarea High Performance Bi-bloc H Generation Single Phase / Three Phase. Heating and Cooling - SDC • R410A refrigerant

			Single Phase		Three Phase (Power to indoor)		
Kit			KIT-WC12H6E5	KIT-WC16H6E5	KIT-WC09H3E8	KIT-WC12H9E8	KIT-WC16H9E8
Heating capacity / COP (A +7 °C, W 35 °C)	kW / COP		12,00/4,74	16,00/4,28	9,00/4,84	12,00/4,74	16,00/4,28
Heating capacity / COP (A +7 °C, W 55 °C)	kW / COP		12,00/2,88	14,50/2,68	9,00/2,94	12,00/2,88	14,50/2,68
Heating capacity / COP (A +2 °C, W 35 °C)	kW / COP		11,40/3,44	13,00/3,28	9,00/3,59	11,40/3,44	13,00/3,28
Heating capacity / COP (A +2 °C, W 55 °C)	kW / COP		9,10/2,20	9,80/2,17	8,80/2,23	9,10/2,20	9,80/2,17
Heating capacity / COP (A -7 °C, W 35 °C)	kW / COP		10,00/2,73	11,40/2,57	9,00/2,85	10,00/2,73	11,40/2,57
Heating capacity / COP (A -7 °C, W 55 °C)	kW / COP		8,20/1,92	9,00/1,82	7,90/2,05	8,20/1,92	9,00/1,82
Cooling capacity / EER (A 35 °C, W 7 °C)	kW / EER		10,00/2,81	12,20/2,56	7,00/3,17	10,00/2,81	12,20/2,56
Cooling capacity / EER (A 35 °C, W 18 °C)	kW / EER		10,00/4,17	12,20/4,12	7,00/4,61	10,00/4,17	12,20/4,12
Seasonal energy efficiency - Heating average climate (W35 °C / W55 °C)	ηs %		190/134	190/130	190/133	190/134	190/130
	SCOP		4,83/3,43	4,83/3,33	4,83/3,40	4,83/3,43	4,83/3,33
Energy class heating average climate (W35 °C / W55 °C)	A+++ to D		A+++ / A++	A+++ / A++	A+++ / A++	A+++ / A++	A+++ / A++
<b>Indoor unit</b>			<b>WH-SDC12H6E5</b>	<b>WH-SDC16H6E5</b>	<b>WH-SDC09H3E8</b>	<b>WH-SDC12H9E8</b>	<b>WH-SDC16H9E8</b>
Sound pressure	Heat / Cool	dB(A)	33/33	33/33	33/33	33/33	33/33
Dimension	HxWxD	mm	892x500x340	892x500x340	892x500x340	892x500x340	892x500x340
Net weight		kg	44	45	44	45	45
Water pipe connector		Inch	R 1½	R 1½	R 1½	R 1½	R 1½
A class pump	Number of speeds		Variable Speed	Variable Speed	Variable Speed	Variable Speed	Variable Speed
	Input power (Min/Max)	W	34/110	30/105	32/102	34/110	30/105
Heating water flow (ΔT=5 K. 35 °C)		L/min	34,4	45,9	25,8	34,4	45,9
Capacity of integrated electric heater		kW	6	6	3	9	9
Power supply 1		A	24,0	26,0	13,1	8,8	9,9
Power supply 2		A	26,0	26,0	13,0	13,0	13,0
Recommended cable size, supply 1 / 2		mm	3x4,0 or 6,0/3x4,0	3x4,0 or 6,0/3x4,0	5x1,5/5x1,5	5x1,5/5x1,5	5x1,5/5x1,5
<b>Outdoor unit</b>			<b>WH-UD12HE5</b>	<b>WH-UD16HE5</b>	<b>WH-UD09HE8</b>	<b>WH-UD12HE8</b>	<b>WH-UD16HE8</b>
Sound power part load <sup>1)</sup>	Heat	dB(A)	65	65	65	65	65
Sound power full load	Heat / Cool	dB(A)	69/68	72/72	68/67	69/68	72/72
Dimension	HxWxD	mm	1340x900x320	1340x900x320	1340x900x320	1340x900x320	1340x900x320
Net weight		kg	101	101	107	107	107
Refrigerant (R410A) / CO <sub>2</sub> Eq.		kg / T	2,55/5,324	2,55/5,324	2,55/5,324	2,55/5,324	2,55/5,324
Pipe diameter	Liquid / Gas	Inch (mm)	3/8(9,52)/5/8(15,88)	3/8(9,52)/5/8(15,88)	3/8(9,52)/5/8(15,88)	3/8(9,52)/5/8(15,88)	3/8(9,52)/5/8(15,88)
Pipe length range		m	3-50	3-50	3-30	3-30	3-30
Elevation difference (in/out)		m	30	30	20	20	20
Pipe length for additional gas		m	10	10	10	10	10
Additional gas amount		g/m	50	50	50	50	50
Operation range	Outdoor ambient	°C	-20 - +35	-20 - +35	-20 - +35	-20 - +35	-20 - +35
Water outlet	Heat / Cool	°C	20 - 55/5 - 20	20 - 55/5 - 20	20 - 55/5 - 20	20 - 55/5 - 20	20 - 55/5 - 20

### Accessories

<b>PAW-TD20C1E5</b>	Tank 200L - Stainless steel
<b>PAW-TD30C1E5</b>	Tank 300L - Stainless steel
<b>PAW-TA20C1E5STD</b>	Tank 200L - Enamelled
<b>PAW-TA30C1E5STD</b>	Tank 300L - Enamelled
<b>PAW-3WYVLV-HW</b>	3 way valve for DHW Tanks
<b>CZ-NV1</b>	3 way valve kit for inside the hydrokit

### Accessories

<b>PAW-BTANK50L-2</b>	Buffer tank 50L
<b>CZ-TAW1</b>	Aquarea Smart Cloud for remote control and maintenance through wireless or wired LAN
<b>CZ-NS4P</b>	Additional functions PCB
<b>PAW-A2W-RTWIRED</b>	Room thermostat
<b>PAW-A2W-RTWIRELESS</b>	Wireless LCD room thermostat

1) Sound power in accordance to 8112013,81312013 and EN12102-1:2017 at +7 °C. EER and COP calculation is based in accordance to EN14511.



-23 °C OUTDOOR TEMPERATURE: After cut-off at -23 °C compressor restarts at -20 °C. INTERNET CONTROL: Optional.  
GOOD DESIGN AWARD 2017: Indoor units All in One and Bi-bloc J and H Generation awarded with the prestigious Good Design Award 2017.

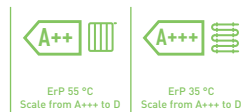

**CZ-TAW1**  
Cloud connection.  
For user control and  
installer remote  
maintenance.

## Aquarea T-CAP Bi-bloc H Generation Single Phase / Three Phase. Heating and Cooling - SXC • R410A refrigerant

Kit	Single Phase (Power to indoor)			Three Phase (Power to indoor)		
	KIT-WXC09H3E5	KIT-WXC12H6E5	KIT-WXC09H3E8	KIT-WXC12H9E8	KIT-WXC16H9E8	
Heating capacity / COP [A +7 °C, W 35 °C]	kW / COP	9,00/4,84	12,00/4,74	9,00/4,84	12,00/4,74	16,00/4,28
Heating capacity / COP [A +7 °C, W 55 °C]	kW / COP	9,00/2,94	12,00/2,88	9,00/2,94	12,00/2,88	16,00/2,71
Heating capacity / COP [A +2 °C, W 35 °C]	kW / COP	9,00/3,59	12,00/3,44	9,00/3,59	12,00/3,44	16,00/3,10
Heating capacity / COP [A +2 °C, W 55 °C]	kW / COP	9,00/2,21	12,00/2,19	9,00/2,21	12,00/2,19	16,00/2,13
Heating capacity / COP [A -7 °C, W 35 °C]	kW / COP	9,00/2,85	12,00/2,72	9,00/2,85	12,00/2,72	16,00/2,49
Heating capacity / COP [A -7 °C, W 55 °C]	kW / COP	9,00/2,02	12,00/1,92	9,00/2,02	12,00/1,92	16,00/1,86
Cooling capacity / EER [A 35 °C, W 7 °C]	kW / EER	7,00/3,17	10,00/2,81	7,00/3,17	10,00/2,81	12,20/2,57
Cooling capacity / EER [A 35 °C, W 18 °C]	kW / EER	7,00/5,19	10,00/5,13	7,00/5,19	10,00/5,13	12,20/3,49
Seasonal energy efficiency - Heating average climate [W35 °C / W55 °C]	ηs %	181/130	170/130	181/130	170/130	160/125
Energy class heating average climate [W35 °C / W55 °C]	SCOP	4,60/3,33	4,33/3,33	4,60/3,33	4,33/3,33	4,08/3,20
Energy class heating average climate [W35 °C / W55 °C]	A+++ to D	A+++ / A++	A++ / A++	A+++ / A++	A++ / A++	A++ / A++
<b>Indoor unit</b>		<b>WH-SXC09H3E5</b>	<b>WH-SXC12H6E5</b>	<b>WH-SXC09H3E8</b>	<b>WH-SXC12H9E8</b>	<b>WH-SXC16H9E8</b>
Sound pressure	Heat / Cool	dB(A)		33/33	33/33	33/33
Dimension	HxWxD	mm		892x500x340	892x500x340	892x500x340
Net weight		kg		43	43	45
Water pipe connector		Inch		R 1½	R 1½	R 1½
A class pump	Number of speeds	Variable Speed		Variable Speed	Variable Speed	Variable Speed
	Input power (Min/Max)	W		32/102	34/110	30/105
Heating water flow [ΔT=5 K, 35 °C]		L/min		25,8	34,4	45,9
Capacity of integrated electric heater		kW		3	6	9
Power supply 1		A		29,0	29,0	15,5
Power supply 2		A		13,0	26,0	13,0
Recommended cable size, supply 1 / 2		mm		3x4,0 or 6,0/3x4,0	3x4,0 or 6,0/3x4,0	5x1,5/3x1,5
<b>Outdoor unit</b>		<b>WH-UX09HE5</b>	<b>WH-UX12HE5</b>	<b>WH-UX09HE8</b>	<b>WH-UX12HE8</b>	<b>WH-UX16HE8</b>
Sound power part load <sup>1)</sup>	Heat	dB(A)		66	66	65
Sound power full load	Heat / Cool	dB(A)		68/67	69/68	68/67
Dimension	HxWxD	mm		1340x900x320	1340x900x320	1340x900x320
Net weight		kg		101	101	108
Refrigerant (R410A) / CO <sub>2</sub> Eq.		kg / T		2,85/5,951	2,85/5,951	2,85/5,951
Pipe diameter	Liquid / Gas	Inch (mm)		3/8(9,52)/5/8(15,88)	3/8(9,52)/5/8(15,88)	3/8(9,52)/5/8(15,88)
Pipe length range		m		3-30	3-30	3-30
Elevation difference (in/out)		m		30	30	30
Pipe length for additional gas		m		10	10	10
Additional gas amount		g/m		50	50	50
Operation range	Outdoor ambient	°C		-28~+35	-28~+35	-28~+35
Water outlet	Heat / Cool	°C		20-60/5-20	20-60/5-20	20-60/5-20

### Accessories

<b>PAW-TD20C1E5</b>	Tank 200L - Stainless steel
<b>PAW-TD30C1E5</b>	Tank 300L - Stainless steel
<b>PAW-TA20C1E5STD</b>	Tank 200L - Enamelled
<b>PAW-TA30C1E5STD</b>	Tank 300L - Enamelled
<b>PAW-3WYVLV-HW</b>	3 way valve for DHW Tanks
<b>CZ-NV1</b>	3 way valve kit for inside the hydrokit

### Accessories

<b>PAW-BTANK50L-2</b>	Buffer tank 50L
<b>CZ-TAW1</b>	Aquarea Smart Cloud for remote control and maintenance through wireless or wired LAN
<b>CZ-NS4P</b>	Additional functions PCB
<b>PAW-A2W-RTWIRED</b>	Room thermostat
<b>PAW-A2W-RTWIRELESS</b>	Wireless LCD room thermostat

1) Sound power in accordance to 8112013,81312013 and EN12102-1:2017 at +7 °C. EER and COP calculation is based in accordance to EN14511.



INTERNET CONTROL: Optional.

GOOD DESIGN AWARD 2017: Indoor units All in One and Bi-bloc J and H Generation awarded with the prestigious Good Design Award 2017.

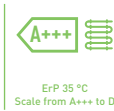
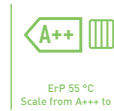

**CZ-TAW1**  
Cloud connection.  
For user control and  
installer remote  
maintenance.

## Aquarea T-CAP Bi-bloc H Generation Three Phase. Super Quiet outdoor unit. Heating and Cooling - SQC • R410A refrigerant

			Three Phase (Power to indoor)		
Kit			KIT-WQC09H3E8	KIT-WQC12H9E8	KIT-WQC16H9E8
Heating capacity / COP (A +7 °C, W 35 °C)	kW / COP		9,00/4,84	12,00/4,74	16,00/4,28
Heating capacity / COP (A +7 °C, W 55 °C)	kW / COP		9,00/2,94	12,00/2,88	16,00/2,71
Heating capacity / COP (A +2 °C, W 35 °C)	kW / COP		9,00/3,59	12,00/3,44	16,00/3,10
Heating capacity / COP (A +2 °C, W 55 °C)	kW / COP		9,00/2,21	12,00/2,19	16,00/2,13
Heating capacity / COP (A -7 °C, W 35 °C)	kW / COP		9,00/2,85	12,00/2,72	16,00/2,49
Heating capacity / COP (A -7 °C, W 55 °C)	kW / COP		9,00/2,02	12,00/1,92	16,00/1,86
Cooling capacity / EER (A 35 °C, W 7 °C)	kW / EER		7,00/3,17	10,00/2,81	12,20/2,57
Cooling capacity / EER (A 35 °C, W 18 °C)	kW / EER		7,00/5,19	10,00/5,13	12,20/3,49
Seasonal energy efficiency - Heating average climate (W35 °C / W55 °C)	ηs %		181/130	170/130	160/125
Energy class heating average climate (W35 °C / W55 °C)	SCOP		4,60/3,33	4,33/3,33	4,08/3,20
Energy class heating average climate (W35 °C / W55 °C)	A+++ to D		A+++ / A++	A++ / A++	A++ / A++
Indoor unit			WH-SQC09H3E8	WH-SQC12H9E8	WH-SQC16H9E8
Sound pressure	Heat / Cool	dB(A)	33/33	33/33	33/33
Dimension	HxWxD	mm	892x500x340	892x500x340	892x500x340
Net weight		kg	43	44	45
Water pipe connector		Inch	R 1¼	R 1¼	R 1¼
A class pump	Number of speeds		Variable Speed	Variable Speed	Variable Speed
	Input power (Min/Max)	W	32/102	34/110	30/105
Heating water flow (ΔT=5 K. 35 °C)		L/min	25,8	34,4	45,9
Capacity of integrated electric heater		kW	3	9	9
Power supply 1		A	14,7	11,9	15,5
Power supply 2		A	13,0	13,0	13,0
Recommended cable size, supply 1 / 2		mm	5x1,5/3x1,5	5x1,5/5x1,5	5x1,5/5x1,5
Outdoor unit			WH-UQ09H8E8	WH-UQ12H8E8	WH-UQ16H8E8
Sound power part load <sup>1)</sup>	Heat	dB(A)	58	58	62
Sound power full load	Heat / Cool	dB(A)	61/63	62/64	65/68
Dimension	HxWxD	mm	1410x1283x320	1410x1283x320	1410x1283x320
Net weight		kg	151	151	161
Refrigerant (R410A) / CO <sub>2</sub> Eq.		kg / T	2,85/5,951	2,85/5,951	2,99/6,243
Pipe diameter	Liquid / Gas	Inch (mm)	3/8(9,52)/5/8(15,88)	3/8(9,52)/5/8(15,88)	3/8(9,52)/5/8(15,88)
Pipe length range		m	3-30	3-30	3-30
Elevation difference (in/out)		m	20	20	20
Pipe length for additional gas		m	10	10	10
Additional gas amount		g/m	50	50	50
Operation range	Outdoor ambient	°C	-28 - +35	-28 - +35	-28 - +35
Water outlet	Heat / Cool	°C	20 - 60/5 - 20	20 - 60/5 - 20	20 - 60/5 - 20

### Accessories

<b>PAW-TD20C1E5</b>	Tank 200L - Stainless steel
<b>PAW-TD30C1E5</b>	Tank 300L - Stainless steel
<b>PAW-TA20C1E5STD</b>	Tank 200L - Enamelled
<b>PAW-TA30C1E5STD</b>	Tank 300L - Enamelled
<b>PAW-3WYVLV-HW</b>	3 way valve for DHW Tanks
<b>CZ-NV1</b>	3 way valve kit for inside the hydrokit

### Accessories

<b>PAW-BTANK50L-2</b>	Buffer tank 50L
<b>CZ-TAW1</b>	Aquarea Smart Cloud for remote control and maintenance through wireless or wired LAN
<b>CZ-NS4P</b>	Additional functions PCB
<b>PAW-A2W-RTWIRED</b>	Room thermostat
<b>PAW-A2W-RTWIRELESS</b>	Wireless LCD room thermostat

1) Sound power in accordance to 8112013,81312013 and EN12102-1:2017 at +7 °C. EER and COP calculation is based in accordance to EN14511.



INTERNET CONTROL: Optional.

GOOD DESIGN AWARD 2017: Indoor units All in One and Bi-bloc J and H Generation awarded with the prestigious Good Design Award 2017.

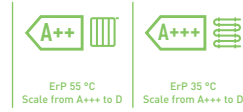

**CZ-TAW1**  
Cloud connection.  
For user control and  
installer remote  
maintenance.

## Aquarea High Performance Mono-bloc H Generation Single Phase. Heating and Cooling - MDC • R410A refrigerant

			Single Phase				
Outdoor unit			WH-MDC05H3E5	WH-MDC07H3E5	WH-MDC09H3E5	WH-MDC12H6E5	WH-MDC16H6E5
Heating capacity / COP [A +7 °C, W 35 °C]	kW / COP		5,00/5,08	7,00/4,52	9,00/4,29	12,00/4,74	16,00/4,28
Heating capacity / COP [A +7 °C, W 55 °C]	kW / COP		5,00/2,84	7,00/2,83	9,00/2,72	12,00/2,93	14,50/2,72
Heating capacity / COP [A +2 °C, W 35 °C]	kW / COP		4,80/3,36	6,60/3,30	6,80/3,18	11,40/3,44	13,00/3,28
Heating capacity / COP [A +2 °C, W 55 °C]	kW / COP		4,00/2,33	6,30/2,22	6,30/2,13	9,10/2,23	9,80/2,21
Heating capacity / COP [A -7 °C, W 35 °C]	kW / COP		4,70/2,85	5,50/2,70	6,40/2,60	10,00/2,73	11,40/2,57
Heating capacity / COP [A -7 °C, W 55 °C]	kW / COP		4,30/1,89	5,00/1,82	5,80/1,78	8,20/1,95	9,00/1,84
Cooling capacity / EER [A 35 °C, W 7 °C]	kW / EER		4,50/3,28	6,00/2,78	7,00/2,60	10,00/2,81	12,20/2,56
Cooling capacity / EER [A 35 °C, W 18 °C]	kW / EER		5,10/5,10	6,00/3,87	7,00/3,59	10,00/4,65	12,20/4,12
Seasonal energy efficiency - Heating average climate [W35 °C / W55 °C]	ηs %		199/139	190/130	190/130	190/134	190/130
	SCOP		5,05/3,55	4,83/3,33	4,83/3,33	4,83/3,43	4,83/3,33
Energy class heating average climate [W35 °C / W55 °C]	A+++ to D		A+++ / A++	A+++ / A++	A+++ / A++	A+++ / A++	A+++ / A++
Sound power part load <sup>1)</sup> Heat	dB(A)		55	59	59	65	65
Sound power full load Heat / Cool	dB(A)		65/65	68/66	69/67	69/68	72/72
Dimension	H x W x D	mm	865 x 1283 x 320	865 x 1283 x 320	865 x 1283 x 320	1410 x 1283 x 320	1410 x 1283 x 320
Net weight		kg	94	104	104	140	140
Refrigerant [R410A] / CO <sub>2</sub> Eq. <sup>2)</sup>		kg / T	1,30/2714	1,35/2819	1,35/2819	2,10/4,385	2,10/4,385
Water pipe connector		Inch	R 1½	R 1½	R 1½	R 1½	R 1½
Pump	Number of speeds		Variable Speed	Variable Speed	Variable Speed	Variable Speed	Variable Speed
	Input power [Min/Max]	W	34/96	36/100	39/108	34/110	38/120
Heating water flow [ΔT=5 K, 35 °C]		L/min	14,3	20,1	25,8	34,4	45,9
Capacity of integrated electric heater		kW	3	3	3	6	6
Input Power	Heat	kW	0,985	1,55	2,10	2,53	3,74
	Cool	kW	1,37	2,16	2,69	3,56	4,76
Running and Starting current	Heat	A	4,7	7,2	9,6	11,7	16,9
	Cool	A	6,3	9,9	12,2	16,2	21,5
Power supply 1		A	13,0	21,0	22,9	24,0	26,0
Power supply 2		A	13,0	13,0	13,0	26,0	26,0
Recommended cable size, supply 1 / 2		mm <sup>2</sup>	3x4,0 or 6,0/3x4,0	3x4,0 or 6,0/3x4,0	3x4,0 or 6,0/3x4,0	3x4,0 or 6,0/3x4,0	3x4,0 or 6,0/3x4,0
Operation range	Outdoor ambient	°C	-20 ~ +35	-20 ~ +35	-20 ~ +35	-20 ~ +35	-20 ~ +35
	Heat	°C	20 ~ 55	20 ~ 55	20 ~ 55	25 ~ 55	25 ~ 55
Water outlet	Heat	°C	20 ~ 55	20 ~ 55	20 ~ 55	25 ~ 55	25 ~ 55
	Cool	°C	5 ~ 20	5 ~ 20	5 ~ 20	5 ~ 20	5 ~ 20

### Accessories

<b>PAW-TD20C1E5</b>	Tank 200L - Stainless steel
<b>PAW-TD30C1E5</b>	Tank 300L - Stainless steel
<b>PAW-TA20C1E5STD</b>	Tank 200L - Enamelled
<b>PAW-TA30C1E5STD</b>	Tank 300L - Enamelled
<b>PAW-TD20B8E3-1</b>	Combo Tank 185L + 80L - Enamelled
<b>PAW-TD23B6E5</b>	Combo Tank 230L + 60L - Stainless Steel

### Accessories

<b>PAW-3WYVLV-HW</b>	3 way valve for DHW Tanks
<b>PAW-BTANK50L-2</b>	Buffer tank 50L
<b>CZ-TAW1</b>	Aquarea Smart Cloud for remote control and maintenance through wireless or wired LAN
<b>PAW-A2W-RTWIRED</b>	Room thermostat
<b>PAW-A2W-RTWIRELESS</b>	Wireless LCD room thermostat

1) Sound power in accordance to 8112013,81312013 and EN12102-1:2017 at +7 °C. 2) WH-MDC models are hermetically sealed. EER and COP calculation is based in accordance to EN14511.



-23 °C OUTDOOR TEMPERATURE: After cut-off at -23 °C compressor restarts at -20 °C. INTERNET CONTROL: Optional.



**011-1W0206**  
For WH-MXC09H3E5  
and WH-MXC12H6E5

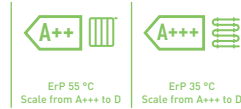

**CZ-TAW1**  
Cloud connection.  
For user control and  
installer remote  
maintenance.

## Aquarea T-CAP Mono-bloc H Generation Single Phase / Three Phase. Heating and Cooling - MXC • R410A refrigerant

Outdoor unit		Single Phase			Three Phase	
		WH-MXC09H3E5	WH-MXC12H6E5	WH-MXC09H3E8	WH-MXC12H9E8	WH-MXC16H9E8
Heating capacity / COP (A +7 °C, W 35 °C)	kW / COP	9,00/4,84	12,00/4,74	9,00/4,84	12,00/4,74	16,00/4,28
Heating capacity / COP (A +7 °C, W 55 °C)	kW / COP	9,00/2,94	12,00/2,88	9,00/2,94	12,00/2,88	16,00/2,71
Heating capacity / COP (A +2 °C, W 35 °C)	kW / COP	9,00/3,59	12,00/3,44	9,00/3,59	12,00/3,44	16,00/3,10
Heating capacity / COP (A +2 °C, W 55 °C)	kW / COP	9,00/2,21	12,00/2,19	9,00/2,21	12,00/2,19	16,00/2,13
Heating capacity / COP (A -7 °C, W 35 °C)	kW / COP	9,00/2,85	12,00/2,72	9,00/2,85	12,00/2,72	16,00/2,49
Heating capacity / COP (A -7 °C, W 55 °C)	kW / COP	9,00/2,02	12,00/1,92	9,00/2,02	12,00/1,92	16,00/1,86
Cooling capacity / EER (A 35 °C, W 7 °C)	kW / EER	7,00/3,17	10,00/2,81	7,00/3,17	10,00/2,81	12,20/2,56
Cooling capacity / EER (A 35 °C, W 18 °C)	kW / EER	7,00/5,19	10,00/5,13	7,00/5,19	10,00/5,13	12,20/3,49
Seasonal energy efficiency - Heating average climate (W35 °C / W55 °C)	ηs %	181/130	170/130	181/130	170/130	160/125
Energy class heating average climate (W35 °C / W55 °C)	SCOP	4,60/3,33	4,33/3,33	4,60/3,33	4,33/3,33	4,08/3,20
Energy class heating average climate (W35 °C / W55 °C)	A+++ to D	A+++ / A++	A++ / A++	A+++ / A++	A++ / A++	A++ / A++
Sound power part load <sup>1)</sup>	Heat	dB(A)		65	65	66
Sound power full load	Heat / Cool	dB(A)		68/67	69/68	72/71
Dimension	HxWxD	mm		1410x1283x320	1410x1283x320	1410x1283x320
Net weight		kg		142	151	164
Refrigerant (R410A) / CO <sub>2</sub> Eq. <sup>2)</sup>		kg / T		2,30/4,802	2,30/4,802	2,35/4,907
Water pipe connector		Inch		R 1½	R 1½	R 1½
Pump	Number of speeds	Variable Speed		Variable Speed	Variable Speed	Variable Speed
	Input power (Min/Max)	W		32/102	34/110	38/120
Heating water flow (ΔT=5 K. 35 °C)		L/min		25,8	34,4	45,9
Capacity of integrated electric heater		kW		3	3	9
Input Power	Heat	kW		1,86	2,53	3,74
	Cool	kW		2,21	3,56	4,76
Running and Starting current	Heat	A		8,8	11,7	5,7
	Cool	A		10,4	16,5	7,1
Power supply 1		A		29,0	14,7	15,5
Power supply 2		A		13,0	26,0	13,0
Recommended cable size, supply 1 / 2		mm <sup>2</sup>		3x4,0 or 6,0/3x4,0	3x4,0 or 6,0/3x4,0	5x1,5/3x1,5
Operation range	Outdoor ambient	°C		-20 ~ +35	-20 ~ +35	-20 ~ +35
	Heat	°C		20 ~ 60	20 ~ 60	20 ~ 60
Water outlet	Heat	°C		20 ~ 60	20 ~ 60	20 ~ 60
	Cool	°C		5 ~ 20	5 ~ 20	5 ~ 20

### Accessories

<b>PAW-TD20C1E5</b>	Tank 200L - Stainless steel
<b>PAW-TD30C1E5</b>	Tank 300L - Stainless steel
<b>PAW-TA20C1E5STD</b>	Tank 200L - Enamelled
<b>PAW-TA30C1E5STD</b>	Tank 300L - Enamelled
<b>PAW-TD20B8E3-1</b>	Combo Tank 185L + 80L - Enamelled
<b>PAW-TD23B6E5</b>	Combo Tank 230L + 60L - Stainless Steel

### Accessories

<b>PAW-3WYVLV-HW</b>	3 way valve for DHW Tanks
<b>PAW-BTANK50L-2</b>	Buffer tank 50L
<b>CZ-TAW1</b>	Aquarea Smart Cloud for remote control and maintenance through wireless or wired LAN
<b>PAW-A2W-RTWIRED</b>	Room thermostat
<b>PAW-A2W-RTWIREDLESS</b>	Wireless LCD room thermostat

1) Sound power in accordance to 8112013,81312013 and EN12102-1:2017 at +7 °C. 2) WH-MXC models are hermetically sealed. EER and COP calculation is based in accordance to EN14511.

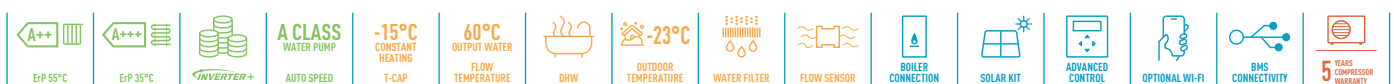

-23 °C OUTDOOR TEMPERATURE: After cut-off at -23 °C compressor restarts at -20 °C. INTERNET CONTROL: Optional.

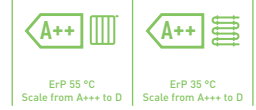

## Aquarea HT Bi-bloc F Generation Single Phase / Three Phase. Heating Only - SHF • R407C refrigerant

Kit	Single Phase (Power to indoor)		Three Phase (Power to indoor)		
	KIT-WHF09F3E5	KIT-WHF12F6E5	KIT-WHF09F3E8	KIT-WHF12F9E8	
Heating capacity / COP [A +7 °C, W 35 °C]	kW / COP	9,00/4,64	12,00/4,46	9,00/4,64	12,00/4,46
Heating capacity / COP [A +7 °C, W 65 °C]	kW / COP	9,00/2,48	12,00/2,41	9,00/2,48	12,00/2,41
Heating capacity / COP [A +2 °C, W 35 °C]	kW / COP	9,00/3,45	12,00/3,26	9,00/3,45	12,00/3,26
Heating capacity / COP [A +2 °C, W 65 °C]	kW / COP	9,00/2,06	10,30/2,01	9,00/2,06	10,30/2,01
Heating capacity / COP [A -7 °C, W 35 °C]	kW / COP	9,00/2,74	12,00/2,52	9,00/2,74	12,00/2,52
Heating capacity / COP [A -7 °C, W 65 °C]	kW / COP	9,00/1,79	9,60/1,77	9,00/1,79	9,60/1,77
Seasonal energy efficiency - Heating average climate (W35 °C / W55 °C)	ηs %	153/125	150/125	153/125	150/125
	SCOP	3,90/3,20	3,83/3,20	3,90/3,20	3,83/3,20
Energy class heating average climate (W35 °C / W55 °C)	A+++ to D	A++/A++	A++/A++	A++/A++	A++/A++
<b>Indoor unit</b>		<b>WH-SHF09F3E5</b>	<b>WH-SHF12F6E5</b>	<b>WH-SHF09F3E8</b>	<b>WH-SHF12F9E8</b>
Sound pressure	dB(A)	33	33	33	33
Dimension	HxWxD	mm	892x502x353	892x502x353	892x502x353
Net weight	kg	46	47	47	48
Water pipe connector	Inch	R 1½	R 1½	R 1½	R 1½
A class pump	Number of speeds	7	7	7	7
	Input power (Min/Max)	W	38/100	40/106	38/100
Heating water flow (ΔT=5 K, 35 °C)	L/min	25,8	34,4	25,8	34,4
Capacity of integrated electric heater	kW	3	6	3	9
Power supply 1	A	28,5	29,0	14,5	10,8
Power supply 2	A	13,0	26,0	13,0	13,0
Recommended cable size, supply 1 / 2	mm	3x4,0 or 6,0/3x4,0	3x4,0 or 6,0/3x4,0	5x1,5/3x1,5	5x1,5/5x1,5
<b>Outdoor unit</b>		<b>WH-UH09FE5</b>	<b>WH-UH12FE5</b>	<b>WH-UH09FE8</b>	<b>WH-UH12FE8</b>
Sound power part load <sup>1)</sup>	dB(A)	—	—	—	—
Sound power full load	dB(A)	66	67	66	67
Dimension	HxWxD	mm	1340x900x320	1340x900x320	1340x900x320
Net weight	kg	104	104	110	110
Refrigerant (R407C) / CO <sub>2</sub> Eq.	kg / T	2,90/5,145	2,90/5,145	2,90/5,145	2,90/5,145
Pipe diameter	Liquid / Gas	Inch (mm)	3/8 (9,52) / 5/8 (15,88)	3/8 (9,52) / 5/8 (15,88)	3/8 (9,52) / 5/8 (15,88)
Pipe length range	m	3-30	3-30	3-30	3-30
Elevation difference (in/out)	m	20	20	20	20
Pipe length for additional gas	m	10	10	10	10
Additional gas amount	g/m	70	70	70	70
Operation range	Outdoor ambient	°C	-20 ~ +35	-20 ~ +35	-20 ~ +35
Water outlet	Heat	°C	25-65	25-65	25-65

### Accessories

<b>PAW-TD20C1E5</b>	Tank 200L - Stainless steel
<b>PAW-TD30C1E5</b>	Tank 300L - Stainless steel
<b>PAW-TA20C1E5STD</b>	Tank 200L - Enamelled
<b>PAW-TA30C1E5STD</b>	Tank 300L - Enamelled

### Accessories

<b>PAW-3WYVLY-HW</b>	3 way valve for DHW Tanks
<b>PAW-BTANK50L-2</b>	Buffer tank 50L
<b>PAW-A2W-RTWIRED</b>	Room thermostat
<b>PAW-A2W-RTWIRELESS</b>	Wireless LCD room thermostat

1) Sound power in accordance to 8112013,81312013 and EN12102-1:2017 at +7 °C. EER and COP calculation is based in accordance to EN14511.



INTERNET CONTROL: Optional.

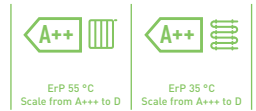

## Aqua HT Mono-bloc G Generation Single Phase. Heating Only - MHF • R407C refrigerant

			Single Phase	
Outdoor unit			WH-MHF09G3E5	WH-MHF12G6E5
Heating capacity / COP (A +7 °C, W 35 °C)	kW / COP		9,00/4,64	12,00/4,46
Heating capacity / COP (A +7 °C, W 65 °C)	kW / COP		9,00/2,48	12,00/2,41
Heating capacity / COP (A +2 °C, W 35 °C)	kW / COP		9,00/3,45	12,00/3,26
Heating capacity / COP (A +2 °C, W 65 °C)	kW / COP		9,00/2,06	10,30/2,01
Heating capacity / COP (A -7 °C, W 35 °C)	kW / COP		9,00/2,74	12,00/2,52
Heating capacity / COP (A -7 °C, W 65 °C)	kW / COP		9,00/1,79	9,60/1,77
Seasonal energy efficiency - Heating average climate (W35 °C / W55 °C)	ηs %		153/125	150/125
	SCOP		3,90/3,20	3,83/3,20
Energy class heating average climate (W35 °C / W55 °C)		A+++ to D	A++/A++	A++/A++
Sound power part load <sup>1)</sup>		dB(A)	—	—
Sound power full load		dB(A)	68	69
Dimension	HxWxD	mm	1410x1283x320	1410x1283x320
Net weight		kg	151	151
Refrigerant (R407C) / CO <sub>2</sub> Eq. <sup>2)</sup>		kg / T	1,92/3,406	1,92/3,406
Water pipe connector		Inch	R 1¼	R 1¼
Pump	Number of speeds		7	7
	Input power (Min/Max)	W	—	—
Heating water flow (ΔT=5 K, 35 °C)		L/min	25,8	34,4
Capacity of integrated electric heater		kW	3	6
Input Power		kW	1,94	2,69
Running and Starting current		A	9,3	12,8
Power supply 1		A	28,5	29,0
Power supply 2		A	13,0	26,0
Recommended cable size, supply 1 / 2		mm <sup>2</sup>	3x4,0 or 6,0/3x4,0	3x4,0 or 6,0/3x4,0
Operation range	Outdoor ambient	°C	-20 ~ +35	-20 ~ +35
Water outlet	Heat	°C	25 ~ 65	25 ~ 65

### Accessories

<b>PAW-TD20C1E5</b>	Tank 200L - Stainless steel
<b>PAW-TD30C1E5</b>	Tank 300L - Stainless steel
<b>PAW-TA20C1E5STD</b>	Tank 200L - Enamelled
<b>PAW-TA30C1E5STD</b>	Tank 300L - Enamelled
<b>PAW-TD20B8E3-1</b>	Combo Tank 185L + 80L - Enamelled

### Accessories

<b>PAW-TD23B6E5</b>	Combo Tank 230L + 60L - Stainless Steel
<b>PAW-3WYVLV-HW</b>	3 way valve for DHW Tanks
<b>PAW-BTANK50L-2</b>	Buffer tank 50L
<b>PAW-A2W-RTWIRED</b>	Room thermostat
<b>PAW-A2W-RTWIRELESS</b>	Wireless LCD room thermostat

1) Sound power in accordance to 8112013,81312013 and EN12102-1:2017 at +7 °C. 2) WH-MHF models are hermetically sealed. EER and COP calculation is based in accordance to EN14511.



INTERNET CONTROL: Optional.

# Smart fan coils

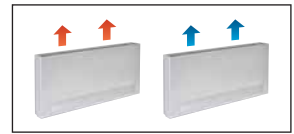

Air flow	Speed	PAW-AAIR-200-2			PAW-AAIR-700-2			PAW-AAIR-900-2		
		Min	Med	Max	Min	Med	Max	Min	Med	Max
<b>Heating mode</b>										
Total heating capacity	W	217,00	470,00	570,00	708,00	1032,00	1188,00	886,00	1420,00	1703,00
Water flow	kg/h	37,30	80,80	98,00	121,80	177,50	204,30	152,40	244,20	292,90
Water pressure drop	kPa	0,40	2,00	2,90	0,30	0,80	1,00	0,50	1,60	2,20
Inlet water temperature	°C	35	35	35	35	35	35	35	35	35
Outlet water temperature	°C	30	30	30	30	30	30	30	30	30
Inlet air temperature	°C	19,00	19,00	19,00	19,00	19,00	19,00	19,00	19,00	19,00
Outlet air temperature	°C	38,90	32,00	30,00	33,30	31,80	30,60	30,20	31,10	30,60
<b>Cooling mode</b>										
Total cooling capacity	W	237,00	345,00	555,00	756,00	1039,00	1204,00	1153,00	1518,00	1746,00
Sensible cooling capacity	W	230,00	314,00	504,00	646,00	903,00	1058,00	1061,00	1384,00	1598,00
Water flow	kg/h	40,00	59,00	95,00	129,00	178,00	207,00	198,00	261,00	300,00
Water pressure drop	kPa	0,40	2,00	2,90	1,00	2,00	2,00	6,00	9,00	12,00
Inlet water temperature	°C	10	10	10	10	10	10	10	10	10
Outlet water temperature	°C	15	15	15	15	15	15	15	15	15
Inlet air temperature	°C	27,00	27,00	27,00	27,00	27,00	27,00	27,00	27,00	27,00
Outlet air temperature	°C	15,00	17,00	18,00	14,00	16,00	17,00	16,00	17,00	18,00
Relative humidity of inlet air	%	47	47	47	47	47	47	47	47	47
Air flow	m <sup>3</sup> /min	0,90	1,90	2,70	2,60	4,20	5,30	4,10	6,10	7,70
Maximum input power	W	7,00	9,00	13,00	14,00	18,00	22,00	16,00	20,00	24,00
Sound pressure	dB(A)	23	33	40	24	36	42	25	36	44
Dimension (HxWxD)	mm	735 x 579 x 129			935 x 579 x 129			1135 x 579 x 129		
Net weight	kg	17			20			23		
3 Ways valve included		Yes			Yes			Yes		
Touch screen thermostat		Yes			Yes			Yes		

**Accessories**  
**PAW-AAIR-LEGS-1** Kits of 2 legs to protect the water pipings

**Accessories**  
**PAW-AAIR-RHCABLE** Motor connection cable for units with hydraulic connections on the right

\* Smart fan coils is produced by Innova.

## Stylish Floor-standing fan coils with advanced controller

The slimline of Smart fan coils delivers high efficiency climate control.

With a depth of just under 13cm they are at the cutting edge of the market. Blending easily into the home, Smart fan coil's elegant design and product refinements are clear to see in every detail.

Exceptional ventilation efficiency means the motor uses considerably less energy (low wattage). The fan speed is continuously modulated by the temperature controller with proportional integral logic, with undoubted advantages for regulating the temperature and humidity in summer mode.

With standard cast radiators.

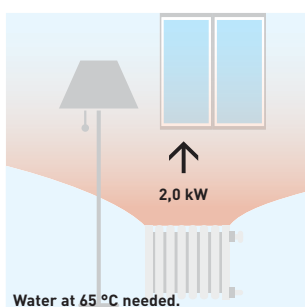

With Smart fan coil.

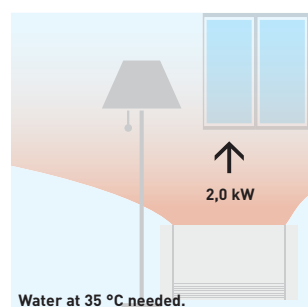

### Technical focus:

- High heating capacity
- 4 operation modes (auto, silent, night-time and maximum ventilation speed)
- Exclusive design
- Extremely compact (only 12,9 cm deep)
- Cooling and dehumidification functions possible (drain is needed)
- 3-way valve included (no overflow valve needed on the installation if more than 3 units installed)
- Touch screen thermostat

All temperature curves and capacity are available on [www.panasonicproclub.com](http://www.panasonicproclub.com)



## Fan coils



**PAW-FC-903TC**  
Optional Controller.  
Wired remote controller.



**PAW-FC-RC1**  
Optional Controller.  
Advanced wired remote controller.

Compact units											High Static Pressure
Left side connection			PAW-FC-D11-1	PAW-FC-D15-1	PAW-FC-D24-1	PAW-FC-D28-1	PAW-FC-D40-1	PAW-FC-D55-1	PAW-FC-D65-1	PAW-FC-D90-1	PAW-FC-H150
Right side connection			PAW-FC-D11-1-R	PAW-FC-D15-1-R	PAW-FC-D24-1-R	PAW-FC-D28-1-R	PAW-FC-D40-1-R	PAW-FC-D55-1-R	PAW-FC-D65-1-R	PAW-FC-D90-1-R	PAW-FC-H150-R
Total cooling capacity <sup>1)</sup>	Med/S-Hi	kW	1,0/1,5	1,2/1,7	2,0/2,5	2,4/3,2	3,2/4,6	4,6/5,8	6,1/7,3	6,1/8,1	11,9/14,8
Sensible cooling capacity <sup>1)</sup>	Med/S-Hi	kW	0,8/1,1	0,9/1,3	1,5/1,9	1,8/2,3	2,2/3,3	3,3/4,5	4,3/5,1	4,6/6,3	9,6/12,9
Heating capacity <sup>1)</sup>	Med/S-Hi	kW	1,4/2,0	1,5/2,2	2,4/3,1	2,9/4,0	4,1/5,7	5,3/7,1	7,9/9,3	8,1/11,6	14,9/19,9
Power consumption	S-Lo/Med/S-Hi	W	13/24/36	10/18/29	16/37/45	15/37/56	28/55/72	37/75/105	53/100/147	90/112/188	180/421/675
Fuse rating	A		2	2	2	2	2	2	2	2	6
Dimensions <sup>2)</sup>	H x W x D	mm	220x570x430	220x570x430	220x753x430	220x938x430	220x1122x430	220x1307x430	220x1121x530	220x1316x530	376x1600x798
Weight <sup>3)</sup>	kg		13	13	15	20	22	26	27	38	63
Sound power global	S-Lo/Med/S-Hi	dB(A)	33/40/49	31/43/50	30/45/52	30/44/51	34/46/56	38/51/58	43/56/61	50/55/64	52/64/71
Sound pressure global	S-Lo/Med/S-Hi	dB(A)	24/31/40	22/34/41	21/36/43	21/35/42	25/37/47	29/42/49	34/47/52	41/46/55	31/45/51
Static pressure	Max	Pa	30	30	50	50	70	70	70	70	110
Air flow <sup>1)</sup>	Med/S-Hi	m <sup>3</sup> /h	190/283	179/265	274/390	357/499	486/716	640/933	893/1064	936/1397	2112/3176
Water pressure drop	Med/S-Hi	kPa	19,5/39,2	3,9/6,3	19,3/28,8	17,1/28	22,8/46,9	37,4/60,2	15,4/21,5	19,3/32,5	19,8/26,1
Fan speeds			3 speeds	3 speeds	3 speeds	3 speeds	3 speeds	3 speeds	3 speeds	3 speeds	3 speeds
Fan motor and number of speeds			AC 5 speeds	AC 5 speeds	AC 5 speeds	AC 5 speeds	AC 5 speeds	AC 5 speeds	AC 5 speeds	AC 5 speeds	AC 5 speeds
Drain pan and air filter			Included	Included	Included	Included	Included	Included	Included	Included	Included
Water connections	Inch		1/2	1/2	1/2	1/2	1/2	1/2	3/4	3/4	1

### Accessories

<b>PAW-FC-RC1</b>	Advanced wired remote controller for fan coil
<b>PAW-FC-903TC</b>	<b>NEW</b> Wired remote controller for fan coil
<b>PAW-FC-2WY-11/55-1</b>	2 way valve + drain pan (for PAW-FC-D11/15/24/28/40/55-1)
<b>PAW-FC-2WY-65/90-1</b>	2 way valve + drain pan (for PAW-FC-D65/90-1)

### Accessories

<b>PAW-FC-2WY-150</b>	2 way valve + drain pan (for PAW-FC-H150)
<b>PAW-FC-3WY-11/55-1</b>	3 way valve + drain pan (for PAW-FC-D11/15/24/28/40/55-1)
<b>PAW-FC-3WY-65/90-1</b>	3 way valve + drain pan (for PAW-FC-D65/90-1)
<b>PAW-FC-3WY-150</b>	3 way valve + drain pan (for PAW-FC-H150)

<sup>1)</sup> Air flow and capacity at 0 Pa of static pressure. <sup>2)</sup> Including pan and electrical box. <sup>3)</sup> Without water content. \* Performances based on: Cooling: Air: 27 °C DB / 19 °C WB, Chilled water: 7 °C / 12 °C - Heating: Air: 20 °C DB, Hot water: 50 °C / 45 °C. \*\* Fan coil units are produced by Systemair.

### Range of fan coil units

Easy to install, improved sound level and performance. The fan coil range consists of a compact ducted range ideal for residential and commercial use and one model with high static pressure for commercial applications. All units are certified by Eurovent, include drain pan and filter and are equipped with a low consumption fan motor. The D type is even more flexible thanks to an L-shaped drain pan. The unit can be installed either in a horizontal or in a vertical position.

**1** Innovation for an optimum comfort

**3** Efficient high-quality coil

**2** Low energy consumption fan

**4** Flexible installation: vertical or horizontal

### Fan coil controller PAW-FC-RC1

This advanced controller provides a higher level of comfort in heating. The sensor can be used as a water flow sensor, stopping the fan when the water temperature is low, avoiding cold drafts in winter. Also is ready to use J Generation feature of defrost mode and stop the fan coil.

#### Features:

- Room thermostat
- 3 outputs, 230 V relays for fan control
- 2 outputs, 230 V relays for heating / cooling control
- Modbus RTU slave
- 1 DI for presence detection (key card switch)
- 1 AI for sensor

# Sanitary Tanks

## Combo Tank.

The best option to combine with Mono-bloc units. DHW tank with buffer tank. Designed for retrofit applications, the DHW tank with a buffer tank is particularly suitable for fast integration on an existing installation. This tank includes a 3-way valve and an "A" Class pump. Easy to install, nice looking, high efficiency for DHW production and for heating.

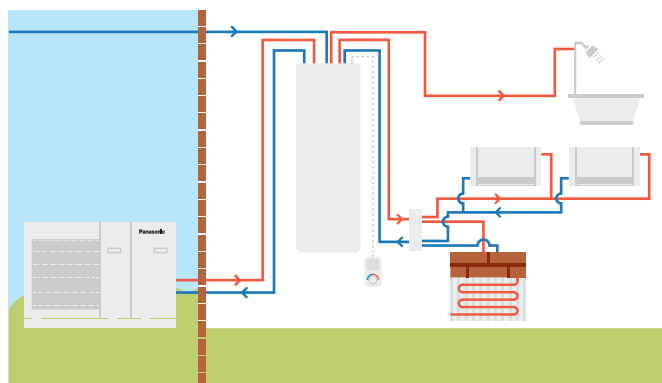

		Enamelled		NEW Stainless steel	
Model		PAW-TD20B8E3-1		PAW-TD23B6E5	
Dimension H x W x D	mm	1770 x 640 x 690		1750 x 600 x 646	
Weight (empty)	kg	150		111	
Volume	L	185 + 80		230 + 60	
Power supply	V, Phase, Hz	230, 1, 50		230, 1, 50	
		Hot water tank		Hot water tank	
Volume	L	185	80	230	60
Max working pressure	MPa (bar)	0,8 (8)	0,6 (6)	1,0 (10)	0,3 (3,0)
Pressure test	MPa (bar)	1,2 (12)	0,9 (9)	1,5 (15)	0,39 (3,9)
Max working temp	°C	90	90	80	80
Connections	mm	Ø22	Ø22	Ø22	Ø22, copper
Material		S 275 JR vitrified		EN 14521	
Insulation	Material, t=mm	PUR, 50		PUR, 50	
Heating coil surface	m <sup>2</sup>	2,1	—	1,8	—
Electrical heater	W	3000	—	2800	—
Energy loss at 65 °C	kWh/24h	1,3	—	1,25	—
<b>Energy efficiency class (from A+ to F)</b>		<b>B</b>		<b>B</b>	
Standing loss	W	53	46	52	29

1) EU Regulation 812/2013. 2) Tested pursuant to EN 12897:2006. \* Enamelled Combo Tank is produced by Lapesa. Stainless Steel Combo Tank is produced by OSO.





## Enamelled Tanks.

Model	Enamelled Tank				Enamelled 2 coils Tank (for bivalent Solar + HP)	NEW Square Tank
	PAW-TA15C1E5STD	PAW-TA20C1E5STD	PAW-TA30C1E5STD	PAW-TA40C1E5STD	PAW-TA30C2E5STD	PAW-TA20C1E5C
Water volume	L	150	200	290	380	200
Maximum water temperature	°C	95	95	95	95	95
Dimensions (Hight / Diameter)	mm	1210/520	1340/610	1800/610	1835/670	1550 x 600 x 600
Weight / filled with water	kg	109/254	90/280	120/389	191/572	134 / 327
Electric heater	kW	—	3,00	3,00	3,00	—
Power supply	V	—	230	230	230	—
Material inside tank		Enamelled	Enamelled	Enamelled	Enamelled	Enamelled
Exchange surface	m <sup>2</sup>	1,2	1,8	2,6	3,8	1,83
Energy loss at 65 °C <sup>1)</sup>	kWh/24h	1,45	1,37	1,61	1,76	1,37
3 way valve accessory PAW-3WYVLV-HW or CZ-NV1		Optional	Optional	Optional	Optional	Built-in 3 way valve
20 m temperature sensor cable included		Yes	Yes	Yes	Yes	Yes
Energy losses	W	60	57	67	73	57
<b>Energy Efficiency Class (from A+ to F)</b>		<b>C</b>	<b>B</b>	<b>B</b>	<b>B</b>	<b>B</b>
Warranty		2 Years	2 Years	2 Years	2 Years	2 Years
Maintenance required		Every 2 years	Every 2 years	Every 2 years	Every 2 years	Every 2 years

1) Insulated tested under EN12897. \*\* Enamelled Tanks and Square Tank are produced by AEmail.



## Stainless Steel Tank.

Model		PAW-TD20C1E5	PAW-TD30C1E5
Water volume	L	192	280
Maximum water temperature	°C	75	75
Dimensions (Hight / Diameter)	mm	1270/595	1750/595
Weight / filled with water	kg	53/—	65/—
Electric heater	kW	1,50	1,50
Power supply	V	230	230
Material inside tank		Stainless steel	Stainless steel
Exchange surface	m <sup>2</sup>	1,8	1,8
Energy loss at 65 °C <sup>1)</sup>	kWh/24h	0,99	1,13
3 way valve accessory PAW-3WYVLV-HW or CZ-NV1		Optional	Optional
20 m temperature sensor cable included		Yes	Yes
Energy losses	W	42	46
<b>Energy Efficiency Class (from A+ to F)</b>		<b>A</b>	<b>A</b>
Warranty		2 Years	2 Years
Maintenance required		No	No

1) Insulated tested under EN12897. \*\* Stainless Steel Tanks and Buffer Tank are produced by OSO.

## NEW Buffer tank.

Model		PAW-BTANK50L-2
Capacity	L	48
Energy losses	W	42
<b>Energy Efficiency Class (from A+ to F)</b>		<b>B</b>
Material		Stainless Steel
Dimensions (Hight / Diameter)	mm	636 / 430
Net weight	kg	—

\* Automatic air vent and drain cock are included. Built-in pocket sensor (sensor not included).

## Accessories for Sanitary tanks

PAW-3WYVLV-HW	3 way valve for DHW Tanks
CZ-NV1	3 way valve kit for inside the hydrokit

## Heat Recovery Ventilation unit

Ventilation systems with heat recovery offer users a high degree of living comfort thanks to temperature controlled and clean air. Heat recovery units are ideal for use in houses, for these owners who are looking for high performance and maximum comfort.



**1 Comfort**  
High thermal comfort.

**2 Energy saving**  
Lower heating requirements thanks to lower heat losses.

**3 Space saving**  
It can be installed over the DHW square tank or the All-in-one Compact indoor unit.

**4 Better user interface**  
Possibility to control the ventilation unit and the heating system with one single remote controller.

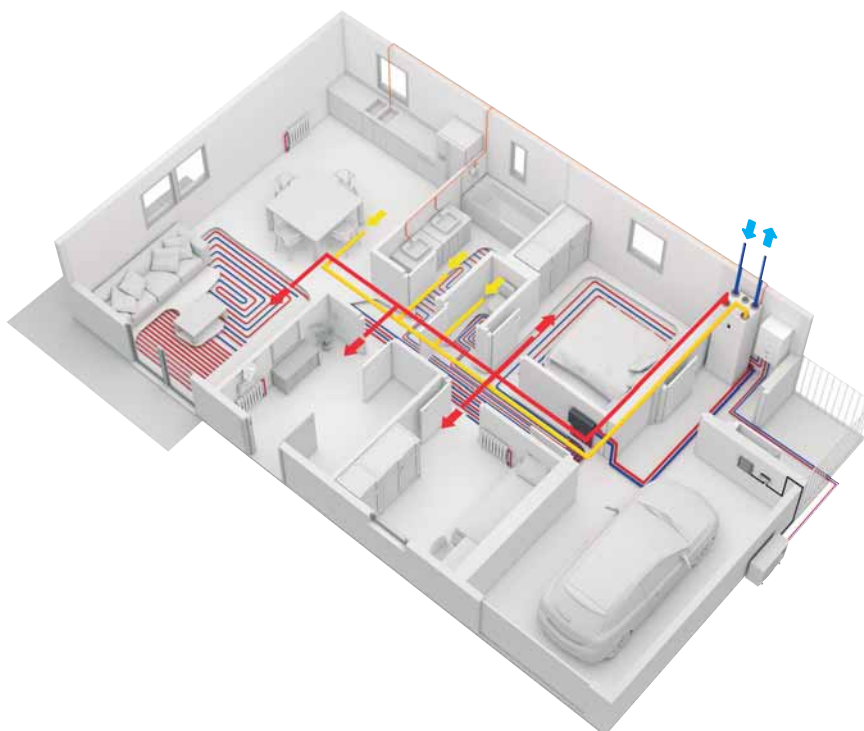



PAW-A2W-VENTA-R

PAW-A2W-VENTA-L

Heat Recovery Ventilation unit		PAW-A2W-VENTA-R	PAW-A2W-VENTA-L
Nominal airflow rate	m <sup>3</sup> /h	204 @ 50 Pa	204 @ 50 Pa
Maximum airflow rate	m <sup>3</sup> /h	292 @ 100 Pa	292 @ 100 Pa
SPF		1,24 @ 204 m <sup>3</sup> /h	1,24 @ 204 m <sup>3</sup> /h
Heat exchanger rotor drive type		Variable speed	Variable speed
Exchanger type		Rotating	Rotating
Heat recovery efficiency		84 %	84 %
Power supply	V / Hz	230 / 50 / 1 phase	230 / 50 / 1 phase
Power consumption	W	176	176
<b>Energy Class, basic unit</b>		<b>A</b>	
<b>Energy Class, unit with local control on demand</b>		<b>A</b>	
Noise level	dB	38	38
Dimensions (W x H x D)	mm	598 x 450 x 500	598 x 450 x 500
Weight	kg	46	46
Mounting position		Vertical	Vertical
Supply side		Right	Left
Duct connections	mm	DN125	DN125
Filter class, supply air		F7/ePM1 60 %	F7/ePM1 60 %
Filter class, extract air		M5/ePM10 50 %	M5/ePM10 50 %
Minimum outdoor temperature	°C	-20	-20

**Accessories**

<b>PAW-VEN-FLTKit</b>	Supply and extract filters kit
<b>PAW-VEN-ACCPCB</b>	Optional PCB for additional functions
<b>PAW-VEN-DPL</b>	HRV touch control panel. White frame (cable must be ordered separately)
<b>PAW-VEN-CBLEXT12</b>	Cable with plug for electrical connection between unit and control panel, type CE and CD (12 m)
<b>PAW-VEN-DIVPLG</b>	Twin plugs for installation of several control panels type CD or CE for one unit

**Accessories**

<b>PAW-VEN-DPLBOX</b>	HRV touch control panel wall-mounted kit
<b>PAW-VEN-S-CO2RH-W</b>	CO <sub>2</sub> RH wall-mounted sensor
<b>PAW-VEN-S-CO2-W</b>	CO <sub>2</sub> wall-mounted sensor
<b>PAW-VEN-S-CO2-D</b>	CO <sub>2</sub> duct sensor
<b>PAW-VEN-PTC12</b>	1,2 kW PTC heater DN125
<b>PAW-VEN-PTC08</b>	0,8 kW PTC heater DN125
<b>PAW-VEN-WBRK</b>	Wall bracket kit for stand-alone installation on the wall

\* Heat recovery efficiency according to EN 13141-7. \*\* Heat Recovery Ventilation unit is produced by Systemair.

With an optimum exchange program, the ventilation unit guides air extracted from the kitchen and bathroom to the outside. Fresh outdoor air is drawn into the unit via the pipe system. Here 84 % of the heat from the extract air is transferred to the supply air via a heat exchanger, which is then supplied back to the living and sleeping quarters.

**Main features:**

- Heat recovery unit designed for ventilated areas up to approximately 165 m<sup>2</sup>.
- High energy-efficiency rotary heat exchanger with EC - technology fans
- Moisture transfer function to minimize condensation in supply air during wintertime
- Control via touch display and Startup Wizard for easy commissioning

- Modbus communication via RS-485
- Option to control Aquarea H and J series heat pumps from PAW-A2W-VENTA control panel if both units are connected via Modbus interface (PAW-AW-MBS-H and PAW-VEN-ACCPCB required)

The built in humidity sensor in extract air can be used for demand control.

**Control**

- All settings and features accessible via a control panel, integrated into the front cover.
- Color touch screen with a user-friendly interface
  - The option for connecting one or more external control panels is available
  - Separate user level for authorized installers and service personnel

- MANUAL and AUTO mode or choose preferred settings from the pre-configured user modes
- If Aquarea H and J series heat pumps are connected with PAW-A2W-VENTA, the heat pump control options will appear on the home screen in a separate tab

The unit can be mounted on a PAW-TA20C1E5C, on a WH-ADC0309J3E5C or installed on the wall (PAW-VEN-WBRK is needed).

## DHW Stand Alone



### DHW Stand Alone: highly efficient heat pump water heater.

The wide range of DHW Stand Alone heat pump is a great solution to adapt to any type of family house. The wall type is available in 100 and 150L capacities, and the Floor-standing in 200 and 270L. For reaching even more efficient use the 270L is available in additional coil, it is able to connect solar water production.

- A+ Highly efficient domestic hot water heat pump
- Provides reduced power consumption by 75 % compared with traditional electric water heater
- Easy to install
- Being CFC-free, this water heater is environmentally friendly

### 1 Energy saving

- Digital control panel with energy consumption monitoring
- Photovoltaic function
- Compatible with ducted fresh air intake installations
- Boiler/Solar Coil (only PAW-DHW270C1F)

### 2 Comfort

- Different modes of operation based on user needs
- Mode AUTO: Intelligent Temperature Set Point, thanks to monitoring hot water usage
- Mode BOOST, Mode ECO and Mode ABSENCE

### 3 Durability

- Diamond-quality enamel lining the inner tank
- Pressure relief valve which provides safety if any malfunctions or pressure rise
- Dielectric union preventing corrosion
- Specific lip gasket preventing rust around the flange



Model Reference		Wall-mounted			Floor-standing	
		PAW-DHW100W-1	PAW-DHW150W-1	PAW-DHW200F	PAW-DHW270F	PAW-DHW270C1F
Nominal capacity	L	100	150	200	270	263
Dimensions (H x W x D)	mm	1209 x 522 x 538	1527 x 522 x 538	1617 x 620 x 665	1957 x 620 x 665	1957 x 620 x 665
Empty weight	kg	57	66	80	92	111
Hot and cold connection		¾" M	¾" M	¾" M	¾" M	¾" M
Anticorrosion system	Anode	Magnesium	Magnesium	Magnesium	Magnesium	Magnesium
Rated water pressure	Mpa (bar)	0,8 (8)	0,8 (8)	0,8 (8)	0,8 (8)	0,8 (8)
Electrical connection	V / Hz	230/50	230/50	230/50	230/50	230/50
Total maximum power	W	1550	1950	2300	2300	2300
Maximal power heat pump	W	350	350	700	700	700
Power electric heating element	W	1200	1600	1600	1600	1600
Heat pump water temperature range	°C	50 – 62	50 – 62	50 – 62	50 – 62	50 – 62
Heat pump air temperature range	°C	-5 – +43	-5 – +43	-5 – +43	-5 – +43	-5 – +43
Duct diameter	mm	125	125	160	160	160
Air flow (without duct)	m³/h	160	160	310/390	310/390	310/390
Load losses acceptable on ventilation circuit, without affecting performance	Pa	70	70	25	25	25
Sound power level <sup>1)</sup>	dB(A)	45	45	53	53	53
R134a refrigerant capacity	kg	0,52	0,58	0,80	0,86	0,86
Refrigerant volume in tons of CO <sub>2</sub> equivalent	TCO <sub>2</sub> Eq.	0,74	0,83	0,50	0,54	0,54
Refrigerant weight per liter	kg/L	0,0052	0,0039	0,0040	0,0032	0,0032
Hot water quantity at 40 °C: V40td	L	151,0	182,0	265,5	361,2	357,9
Acoustic power ErP <sup>2)</sup>	dB(A)	45	45	53	53	53
Energy Efficiency Class (from A+ to F)		<b>A+</b>	<b>A+</b>	<b>A+</b>	<b>A+</b>	<b>A+</b>
Connectable to PV		Yes	Yes	Yes	Yes	Yes
Additional coil exchanger connection		—	—	—	—	1" M
Additional coil surface	m <sup>2</sup>	—	—	—	—	1,2
<b>Performance at 7 °C air temperature</b>		<b>[EN 16147] ducted at 25 Pa</b>		<b>(CDC LCIE 103-15/C) ducted at 30 Pa <sup>3)</sup></b>		
Coefficient of performance (COP) according load profile		2,66 - M	3,05 - L	2,81 - L	3,16 - XL	3,05 - XL
Standby Input power (P <sub>es</sub> )	W	18	24	32	29	33
Heating up time (t <sub>h</sub> )	h. Min	6h47	10h25	07h11	10h39	11h04
Reference hot water temperature (T <sub>ref</sub> )	°C	52,7	53,2	52,7	53,1	52,9
Flow rate (air)	m³/h	140	110	320	320	320
<b>Performance at 15 °C air temperature (EN 16147)</b>						
Coefficient of performance (COP) according load profile		2,88 - M	3,28 - L	3,05 - L	3,61 - XL	3,44 - XL
Standby Input power (P <sub>es</sub> )	W	19	25	30	30	33
Heating up time (t <sub>h</sub> )	h. Min	6h07	9h29	6h24	8h34	8h40
Reference hot water temperature (T <sub>ref</sub> )	°C	52,6	53,4	52,8	53,0	53,1
Flow rate (air)	m³/h	140	110	320	320	320

1) According to ISO3744. 2) Compliant with EN 16147 conditions. 3) Performance measured for a water heater from 10 °C to T<sub>ref</sub> according to the protocol of the NF Electricity Performance Mark specifications No.LCIE 103-15C, selfheating thermodynamic water heaters (based on standard EN 16147). \* DHW Stand Alone is produced by S.A.T.E.

### Ideal for small surfaces

Suitable for all installations (adapted to small surfaces, low ceiling, corner).

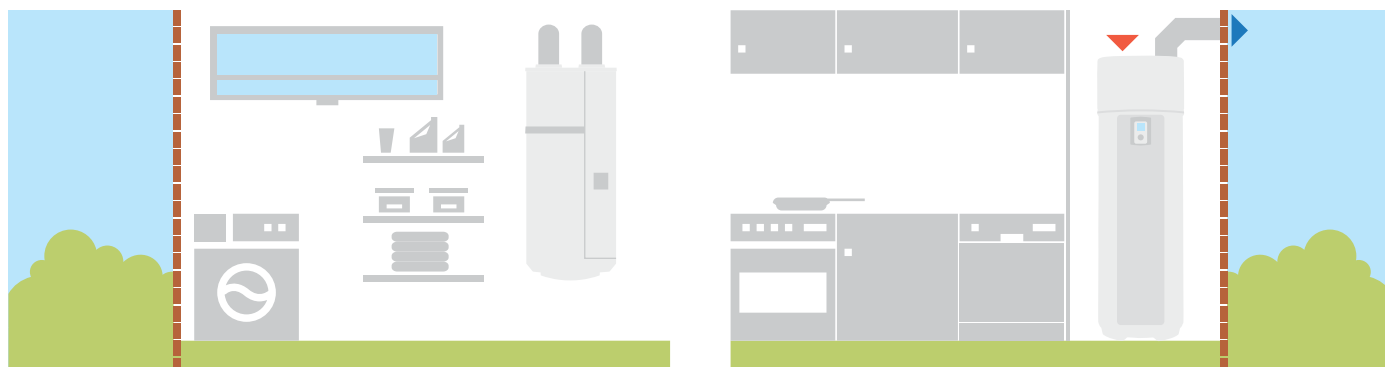

# Accessories and control

## All in One accessories

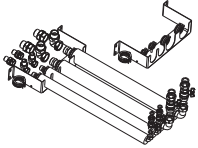

**PAW-ADC-PREKIT-H**  
Flexible pipings and wall mounting plate for All in One H Generation.

**PAW-ADC-PREKIT-1**  
Flexible pipings and wall mounting plate for All in One J Generation (not compatible with WH-ADC0309J3E5C).



**PAW-ADC-CV150**  
Decorative magnetic side cover.

## Special outdoor supports



**PAW-WTRAY**  
Tray for condenser water compatible with base ground support.



**PAW-GRDSTD40**  
Outdoor elevation platform.



**PAW-GRDBSE20**  
Outdoor base ground support for noise and vibration absorption (600 x 95 x 130 mm, 500kg).

## PCB's for additional functions

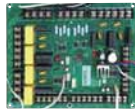

**CZ-NS4P**  
PCB for advanced functions in J and H Generation.

## Deice accessories



**CZ-NE1P**  
Base pan heater (for all old Bi-bloc and Mono-bloc, not for the 3 and 5 kW).

**CZ-NE2P**  
Base pan heater (for Bi-bloc 3 kW and 5 kW).

**CZ-NE3P**  
Base pan heater for J and H Generation.

## Hydraulic accessories

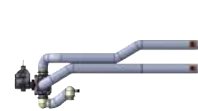

**CZ-NV1**  
3 way valve kit for inside the hydrokit.



**PAW-3WYVLV-HW**  
3 way valve for DHW Tanks.

**PAW-A2W-AFVLV**  
Anti-freeze valve.

## Smart fan coil accessories

**PAW-AAIR-LEGS-1**  
Kits of 2 legs to protect the water pipings.

**PAW-AAIR-RHCABLE**  
Motor connection cable for units with hydraulic connections on the right.

## Fan coil accessories



**PAW-FC-903TC**  
**NEW** Wired remote controller for fan coil.



**PAW-FC-RC1**  
Advanced wired remote controller for fan coil.

**PAW-FC-2WY-11/55-1**  
2 way valve + drain pan (for PAW-FC-D11/15/24/28/40/55-1).

**PAW-FC-2WY-65/90-1**  
2 way valve + drain pan (for PAW-FC-D65/90-1).

**PAW-FC-2WY-150**  
2 way valve + drain pan (for PAW-FC-H150).

**PAW-FC-3WY-11/55-1**  
3 way valve + drain pan (for PAW-FC-D11/15/24/28/40/55-1).

**PAW-FC-3WY-65/90-1**  
3 way valve + drain pan (for PAW-FC-D65/90-1).

**PAW-FC-3WY-150**  
3 way valve + drain pan (for PAW-FC-H150).

## Heat Recovery Ventilation accessories



**PAW-VEN-FLTKIT**  
Supply and extract filters kit.



**PAW-VEN-ACPCB**  
Optional PCB for additional functions.



**PAW-VEN-DPL**  
HRV touch control panel. White frame (cable must be ordered separately).



**PAW-VEN-CBLEXT12**  
Cable with plug for electrical connection between unit and control panel, type CE and CD (12 m).



**PAW-VEN-DIVPLG**  
Twin plugs for installation of several control panels type CD or CE for one unit.



**PAW-VEN-DPLBOX**  
HRV touch control panel wall-mounted kit.



**PAW-VEN-S-CO2RH-W**  
CO<sub>2</sub> RH wall-mounted sensor.



**PAW-VEN-S-CO2-D**  
CO<sub>2</sub> duct sensor.



**PAW-VEN-WBRK**  
Wall bracket kit for stand-alone installation on the wall.

**PAW-VEN-PTC12**  
1,2 kW PTC heater DN125.

**PAW-VEN-PTC08**  
0,8 kW PTC heater DN125.

**PAW-VEN-S-CO2-W**  
CO<sub>2</sub> wall-mounted sensor.



### Sanitary tank accessories



**PAW-TS1**  
Tank sensor with 6 m cable length.

**PAW-TS2**  
Tank sensor with 20 m cable length.

**PAW-TS4**  
Tank sensor with 6 m cable length and only 6 mm diameter.



**CZ-TK1**  
Temperature sensor kit for third party tank [with copper pocket and 6 m length sensor cable].



### DHW Stand Alone accessories

**PAW-DHW-STAND**  
Rack for suspended device for 100 and 150 liters models.

### Connectivity solutions



**CZ-TAW1**  
Aquarea Smart Cloud for remote control and maintenance through wireless or wired LAN.

**CZ-TAW1-CBL**  
10 m extension cable for CZ-TAW1.



**PAW-AW-KNX-1i**  
KNX Interface compatible with G and F Generation.

**PAW-AW-KNX-H**  
KNX Interface for J and H Generation.



**PAW-AW-MBS-1**  
Modbus interface compatible with G and F Generation.

**PAW-AW-MBS-H**  
Modbus Interface for J and H Generation.

### Cascade Controller



**PAW-A2W-CMH**  
Modbus IP for BMS communication.

### Room thermostats



**PAW-A2W-RTWIRED**  
Wired LCD room thermostat with weekly timer.



**PAW-A2W-RTWIRELESS**  
Wireless LCD room thermostat with weekly timer.

### H Generation sensors



**PAW-A2W-TS0D**  
Outdoor ambient sensor.



**PAW-A2W-TSRT**  
Zone room sensor.



**PAW-A2W-TSHC**  
Zone water sensor.



**PAW-A2W-TSS0**  
Solar sensor.



**PAW-A2W-TSBU**  
Buffer tank sensor.

### Aquarea Manager accessories (not compatible with J and H Generation)



**PAW-HPM1**  
Aquarea Manager with LCD.



**PAW-HPM2**  
Aquarea Manager without LCD.



**PAW-HPMED**  
Touch screen.



**PAW-HPMB1**  
Buffer tank sensor.

**PAW-HPMDHW**  
Buffer tank sensor with well.



**PAW-HPMAH1**  
Water flow pipe sensor for heating circuit.



**PAW-HPMUH**  
Outdoor temperature sensor.

**PAW-HPMINT-U**  
Interface to connect Aquarea Manager to Heat pump Aquarea Bi-bloc [HPM can control all parameters from HP].

**PAW-HPMINT-M**  
Interface to connect Aquarea Manager to Heat pump Aquarea Mono-bloc [HPM can control all parameters from HP].

**PAW-HPMINT-F**  
Interface to connect Aquarea Manager to Heat pump Aquarea Mono-bloc and Bi-bloc F type [HPM can control all parameters from HP].

**PAW-HPMSOL1**  
Buffer tank sensor solar [with higher temperature range].

**PAW-HPMR4**  
Room sensor + set point adaptation.

**PAW-DEWPOINTSENSOR**  
Dew point sensor.

# Heating & Cooling capacity tables

Based on outlet temperature and outside temperature.

## Aquarea High Performance Bi-bloc J Generation Single Phase. Heating and Cooling • R32 refrigerant

### WH-UD03JE5

Tamb	HC	IP	COP	HC	IP	COP	HC	IP	COP	HC	IP	COP	HC	IP	COP
LWC	25	25	25	35	35	35	45	45	45	55	55	55	60	60	60
-20	2,50	1,11	2,25	2,52	1,31	1,92	2,24	1,59	1,41	2,12	1,80	1,18	—	—	—
-15	3,00	1,14	2,63	3,20	1,37	2,34	3,00	1,62	1,85	2,75	1,92	1,43	—	—	—
-7	2,99	0,91	3,29	3,30	1,18	2,80	3,25	1,47	2,21	3,20	1,79	1,79	3,00	1,88	1,60
2	2,92	0,69	4,23	3,20	0,88	3,64	3,20	1,13	2,83	3,20	1,46	2,19	3,15	1,67	1,89
7	3,09	0,49	6,31	3,20	0,60	5,33	3,20	0,84	3,81	3,20	1,14	2,81	2,95	1,22	2,42
25	3,27	0,23	14,22	3,27	0,38	8,61	3,61	0,63	5,73	4,06	1,11	3,66	4,03	1,14	3,54

### WH-UD05JE5

Tamb	HC	IP	COP	HC	IP	COP	HC	IP	COP	HC	IP	COP	HC	IP	COP
LWC	25	25	25	35	35	35	45	45	45	55	55	55	60	60	60
-20	3,60	1,57	2,29	3,51	1,81	1,94	3,16	1,99	1,59	2,46	2,11	1,17	—	—	—
-15	4,46	1,72	2,59	4,20	1,93	2,18	3,75	2,18	1,72	3,00	2,12	1,42	—	—	—
-7	4,18	1,33	3,14	4,20	1,62	2,59	3,80	1,82	2,09	3,55	2,08	1,71	3,25	2,15	1,51
2	4,07	1,01	4,03	4,20	1,32	3,18	4,20	1,64	2,56	4,10	2,06	1,99	4,10	2,21	1,86
7	5,20	0,83	6,27	5,00	1,00	5,00	5,00	1,41	3,55	5,00	1,84	2,72	4,25	2,10	2,02
25	5,00	0,52	9,62	5,00	0,72	6,94	5,30	0,98	5,41	5,60	1,27	4,41	4,80	1,27	3,78

### WH-UD07JE5

Tamb	HC	IP	COP	HC	IP	COP	HC	IP	COP	HC	IP	COP	HC	IP	COP
LWC	25	25	25	35	35	35	45	45	45	55	55	55	60	60	60
-20	4,33	1,64	2,64	3,98	1,88	2,12	3,83	2,26	1,69	3,30	2,77	1,19	—	—	—
-15	5,16	1,69	3,05	4,75	2,00	2,38	4,65	2,40	1,94	4,50	2,96	1,52	—	—	—
-7	5,64	1,56	3,62	5,60	1,95	2,87	5,50	2,30	2,39	5,25	2,70	1,94	4,98	2,90	1,72
2	6,80	1,57	4,33	6,85	2,01	3,41	6,75	2,40	2,81	6,20	2,80	2,21	6,18	2,91	2,12
7	7,55	1,15	6,57	7,00	1,47	4,76	7,00	1,96	3,57	7,00	2,48	2,82	6,86	2,75	2,49
25	7,00	0,62	11,29	6,88	0,90	7,64	7,00	1,33	5,26	6,92	1,75	3,95	6,83	1,90	3,59

### WH-UD09JE5-1

Tamb	HC	IP	COP	HC	IP	COP	HC	IP	COP	HC	IP	COP	HC	IP	COP
LWC	25	25	25	35	35	35	45	45	45	55	55	55	60	60	60
-20	4,95	1,93	2,56	6,20	3,00	2,07	5,28	3,09	1,71	4,23	3,33	1,27	—	—	—
-15	7,58	2,70	2,81	7,40	3,20	2,31	6,29	3,26	1,93	5,20	3,42	1,52	—	—	—
-7	6,39	1,81	3,53	6,12	2,20	2,78	5,88	2,61	2,25	5,90	3,06	1,93	5,65	3,24	1,74
2	6,96	1,61	4,32	7,00	2,06	3,40	6,85	2,50	2,74	6,30	2,92	2,16	7,26	3,33	2,18
7	9,44	1,55	6,09	9,00	2,01	4,48	9,00	2,61	3,45	8,95	3,22	2,78	8,62	3,47	2,48
25	8,27	0,95	8,71	8,12	1,29	6,29	8,71	1,80	4,84	7,83	1,97	3,97	6,08	1,72	3,53

## Aquarea High Performance Bi-bloc J Generation Single Phase. Heating and Cooling • R32 refrigerant

Model	WH-UD03JE5									WH-UD05JE5									
	Tamb	CC	IP	EER	CC	IP	EER	CC	IP	EER	CC	IP	EER	CC	IP	EER	CC	IP	EER
LWC	7	7	7	14	14	14	18	18	18	7	7	7	14	14	14	18	18	18	18
16	3,56	0,57	6,25	4,32	0,55	7,85	3,47	0,41	8,46	3,59	0,56	6,41	4,23	0,54	7,83	4,79	0,52	9,21	
25	3,29	0,73	4,51	4,06	0,72	5,64	3,27	0,52	6,29	4,61	1,18	3,91	5,54	1,21	4,58	5,23	0,90	5,81	
35	3,20	0,91	3,52	3,56	0,93	3,83	3,20	0,68	4,71	4,50	1,50	3,00	5,08	1,51	3,36	4,80	1,12	4,29	
43	2,68	1,06	2,53	3,34	1,09	3,06	2,79	0,82	3,40	3,77	1,71	2,20	4,94	1,80	2,74	4,30	1,35	3,19	
Model	WH-UD07JE5									WH-UD09JE5-1									
	Tamb	CC	IP	EER	CC	IP	EER	CC	IP	EER	CC	IP	EER	CC	IP	EER	CC	IP	EER
LWC	7	7	7	14	14	14	18	18	18	7	7	7	14	14	14	18	18	18	18
16	5,20	0,81	6,42	6,62	0,73	9,07	7,04	0,72	9,78	6,85	1,18	5,81	8,80	1,15	7,65	9,11	1,15	7,92	
25	7,40	1,73	4,28	9,30	1,78	5,22	7,65	1,10	6,95	9,00	2,35	3,83	10,40	2,48	4,19	9,10	1,58	5,76	
35	6,70	2,21	3,03	8,10	2,23	3,63	6,70	1,42	4,72	8,20	3,02	2,72	9,90	3,02	3,28	9,00	2,15	4,19	
43	4,50	1,99	2,26	5,44	2,00	2,72	5,10	1,71	2,98	3,80	1,99	1,91	4,70	1,97	2,39	5,35	1,99	2,69	

Tamb: Ambient Temperature (°C). LWC: Leaving Water Condenser Temperature (°C). HC: Heating Capacity (kW). CC: Cooling Capacity (kW). IP: Input power (kW). This data is measured by Panasonic in accordance with EN14511-2 standard. This data is for reference purpose only, and does not guarantee the performance.

## Aqueara High Performance Bi-bloc H Generation Single Phase. Heating and Cooling • R410A refrigerant

## WH-UD03HE5-1

Tamb	HC	IP	COP	HC	IP	COP	HC	IP	COP	HC	IP	COP	HC	IP	COP	HC	IP	COP
LWC	30	30	30	35	35	35	40	40	40	45	45	45	50	50	50	55	55	55
-15	3,20	1,26	2,54	3,20	1,39	2,30	3,10	1,52	2,04	3,00	1,64	1,83	2,80	1,78	1,57	2,75	1,92	1,43
-7	3,20	1,08	2,96	3,20	1,19	2,69	3,20	1,34	2,39	3,20	1,48	2,16	3,20	1,67	1,92	3,20	1,86	1,72
2	3,20	0,82	3,90	3,20	0,90	3,56	3,20	1,03	3,11	3,20	1,16	2,76	3,20	1,33	2,41	3,20	1,49	2,15
7	3,20	0,58	5,52	3,20	0,64	5,00	3,20	0,77	4,16	3,20	0,89	3,60	3,20	1,05	3,05	3,20	1,20	2,67
16	3,20	0,50	6,40	3,20	0,55	5,82	3,20	0,64	5,00	3,20	0,72	4,44	3,20	0,86	3,72	3,20	0,99	3,23
25	3,20	0,42	7,62	3,20	0,46	6,96	3,20	0,55	5,82	3,20	0,63	5,08	3,20	0,73	4,38	3,20	0,82	3,90

## WH-UD05HE5-1

Tamb	HC	IP	COP	HC	IP	COP	HC	IP	COP	HC	IP	COP	HC	IP	COP	HC	IP	COP
LWC	30	30	30	35	35	35	40	40	40	45	45	45	50	50	50	55	55	55
-15	4,20	1,75	2,40	4,20	1,94	2,16	3,80	1,96	1,94	3,40	1,98	1,72	3,20	2,05	1,56	3,00	2,12	1,42
-7	4,20	1,46	2,88	4,20	1,62	2,59	4,00	1,72	2,33	3,80	1,82	2,09	3,70	1,95	1,90	3,55	2,08	1,71
2	4,20	1,22	3,44	4,20	1,35	3,11	4,20	1,50	2,80	4,20	1,65	2,55	4,15	1,86	2,23	4,10	2,07	1,98
7	5,00	0,97	5,15	5,00	1,08	4,63	5,00	1,28	3,91	5,00	1,48	3,38	5,00	1,68	2,98	5,00	1,89	2,65
16	5,00	0,83	6,02	5,00	0,92	5,43	5,00	1,15	4,35	5,00	1,38	3,62	5,00	1,53	3,27	5,00	1,68	2,98
25	5,00	0,74	6,76	5,00	0,82	6,10	5,00	1,02	4,90	5,00	1,22	4,10	5,00	1,35	3,70	5,00	1,49	3,36

## WH-UD07HE5-1

Tamb	HC	IP	COP	HC	IP	COP	HC	IP	COP	HC	IP	COP	HC	IP	COP	HC	IP	COP
LWC	30	30	30	35	35	35	40	40	40	45	45	45	50	50	50	55	55	55
-15	—	—	—	4,60	1,98	2,32	4,60	2,19	2,10	4,60	2,40	1,92	4,55	2,63	1,73	4,50	2,86	1,57
-7	—	—	—	5,15	1,92	2,68	5,08	2,14	2,37	5,00	2,36	2,12	4,90	2,45	2,00	4,80	2,54	1,89
2	—	—	—	6,55	1,96	3,34	6,58	2,29	2,87	6,60	2,62	2,52	6,30	2,82	2,23	6,00	3,01	1,99
7	—	—	—	7,00	1,57	4,46	7,00	1,84	3,80	7,00	2,10	3,33	6,90	2,35	2,94	6,80	2,59	2,63
25	—	—	—	7,00	0,97	7,22	6,74	1,14	5,91	6,48	1,31	4,95	6,24	1,43	4,36	6,00	1,55	3,87

## WH-UD09HE5-1

Tamb	HC	IP	COP	HC	IP	COP	HC	IP	COP	HC	IP	COP	HC	IP	COP	HC	IP	COP
LWC	30	30	30	35	35	35	40	40	40	45	45	45	50	50	50	55	55	55
-15	—	—	—	5,90	2,66	2,22	5,65	2,82	2,00	5,40	2,98	1,81	5,20	3,08	1,69	5,00	3,18	1,57
-7	—	—	—	5,90	2,34	2,52	5,85	2,61	2,24	5,80	2,88	2,01	5,80	2,98	1,95	5,80	3,08	1,88
2	—	—	—	6,70	2,14	3,13	6,65	2,38	2,79	6,60	2,62	2,52	6,30	2,82	2,23	6,00	3,01	1,99
7	—	—	—	9,00	2,18	4,13	9,00	2,49	3,61	9,00	2,79	3,23	8,95	3,25	2,75	8,90	3,70	2,41
25	—	—	—	9,00	1,26	7,14	8,66	1,48	5,85	8,32	1,69	4,92	8,03	1,85	4,34	7,74	2,01	3,85

## WH-UD12HE5

Tamb	HC	IP	COP	HC	IP	COP	HC	IP	COP	HC	IP	COP	HC	IP	COP	HC	IP	COP
LWC	30	30	30	35	35	35	40	40	40	45	45	45	50	50	50	55	55	55
-15	9,30	3,46	2,69	8,90	3,62	2,46	8,50	3,79	2,24	8,10	3,95	2,05	7,50	4,05	1,85	7,00	4,16	1,68
-7	10,40	3,37	3,09	10,00	3,66	2,73	9,60	3,95	2,43	9,20	4,24	2,17	8,70	4,26	2,04	8,20	4,27	1,92
2	11,80	3,10	3,81	11,40	3,31	3,44	11,00	3,53	3,12	10,60	3,74	2,83	9,80	3,94	2,49	9,10	4,14	2,20
7	12,00	2,10	5,71	12,00	2,53	4,74	12,00	2,96	4,05	12,00	3,39	3,54	12,00	3,78	3,17	12,00	4,16	2,88
25	12,00	1,38	8,70	12,00	1,66	7,23	11,80	1,94	6,08	11,70	2,23	5,25	11,50	2,49	4,62	11,40	2,74	4,16

## WH-UD16HE5

Tamb	HC	IP	COP	HC	IP	COP	HC	IP	COP	HC	IP	COP	HC	IP	COP	HC	IP	COP
LWC	30	30	30	35	35	35	40	40	40	45	45	45	50	50	50	55	55	55
-15	10,60	4,09	2,59	10,30	4,38	2,35	10,00	4,67	2,14	9,70	4,96	1,96	8,80	4,94	1,78	7,90	4,91	1,61
-7	11,90	4,03	2,95	11,40	4,43	2,57	10,80	4,83	2,24	10,30	5,22	1,97	9,60	5,09	1,89	9,00	4,95	1,82
2	13,50	3,74	3,61	13,00	3,96	3,28	12,40	4,18	2,97	11,90	4,40	2,70	10,80	4,46	2,42	9,80	4,51	2,17
7	16,00	3,21	4,98	16,00	3,74	4,28	16,00	4,27	3,75	16,00	4,80	3,33	15,20	5,11	2,97	14,50	5,41	2,68
25	16,00	2,31	6,93	16,00	2,69	5,95	16,00	3,07	5,21	16,00	3,45	4,64	16,00	3,67	4,36	15,90	3,89	4,09

Tamb: Ambient Temperature (°C). LWC: Leaving Water Condenser Temperature (°C). HC: Heating Capacity (kW). CC: Cooling Capacity (kW). IP: Input power (kW).  
This data is measured by Panasonic in accordance with EN14511-2 standard. This data is for reference purpose only, and does not guarantee the performance.

# Heating & Cooling capacity tables

Based on outlet temperature and outside temperature.

## Aquarea High Performance Bi-bloc H Generation Single Phase. Heating and Cooling • R410A refrigerant

### WH-UD03HE5-1

Tamb	CC	IP	EER	CC	IP	EER	CC	IP	EER
LWC	7	7	7	14	14	14	18	18	18
18	2,40	0,42	5,71	4,40	0,73	6,03	3,70	0,49	7,55
25	3,20	0,73	4,38	4,10	0,86	4,77	3,50	0,59	5,93
35	3,20	1,04	3,08	3,90	1,07	3,64	3,30	0,74	4,46
43	2,90	1,20	2,42	3,50	1,20	2,92	3,00	0,88	3,41

### WH-UD05HE5-1

Tamb	CC	IP	EER	CC	IP	EER	CC	IP	EER
LWC	7	7	7	14	14	14	18	18	18
18	4,50	0,89	5,06	5,00	0,90	5,56	5,70	0,90	6,33
25	5,00	1,43	3,50	6,30	1,50	4,20	5,40	1,06	5,09
35	4,50	1,67	2,69	5,50	1,68	3,27	5,00	1,33	3,76
43	3,30	1,53	2,16	4,10	1,52	2,70	4,40	1,53	2,88

### WH-UD07HE5-1

Tamb	CC	IP	EER	CC	IP	EER	CC	IP	EER
LWC	7	7	7	14	14	14	18	18	18
18	4,80	0,80	6,00	7,20	1,16	6,21	6,00	1,13	5,31
25	7,00	1,90	3,68	8,47	1,78	4,76	6,00	1,27	4,72
35	6,00	2,28	2,63	6,60	2,48	2,66	6,00	1,68	3,57
43	4,85	2,65	1,83	6,00	2,82	2,13	4,80	1,98	2,42

### WH-UD09HE5-1

Tamb	CC	IP	EER	CC	IP	EER	CC	IP	EER
LWC	7	7	7	14	14	14	18	18	18
18	5,40	1,00	5,40	8,40	1,62	5,19	7,00	1,61	4,35
25	7,85	2,40	3,27	10,20	2,46	4,15	7,00	1,77	3,95
35	7,00	2,88	2,43	7,60	3,20	2,38	7,00	2,15	3,26
43	5,20	2,85	1,82	6,99	3,84	1,82	5,60	2,55	2,20

### WH-UD12HE5

Tamb	CC	IP	EER	CC	IP	EER	CC	IP	EER
LWC	7	7	7	14	14	14	18	18	18
16	7,86	1,18	6,66	13,15	1,40	9,39	10,00	1,73	5,78
25	12,08	2,90	4,17	15,70	2,05	7,66	10,00	1,97	5,08
35	10,00	2,56	3,91	12,00	2,67	4,49	10,00	2,40	4,17
43	7,80	3,80	2,05	11,10	3,19	3,48	8,00	2,85	2,81

### WH-UD16HE5

Tamb	CC	IP	EER	CC	IP	EER	CC	IP	EER
LWC	7	7	7	14	14	14	18	18	18
16	9,20	1,62	5,68	16,40	2,58	6,36	12,20	2,45	4,98
25	14,40	3,92	3,67	19,20	3,83	5,01	12,20	2,79	4,37
35	12,20	4,76	2,56	15,00	4,98	3,01	12,20	2,96	4,12
43	7,75	3,40	2,28	13,80	5,95	2,32	9,70	4,00	2,43

Tamb: Ambient Temperature (°C). LWC: Leaving Water Condenser Temperature (°C). HC: Heating Capacity (kW). CC: Cooling Capacity (kW). IP: Input power (kW). This data is measured by Panasonic in accordance with EN14511-2 standard. This data is for reference purpose only, and does not guarantee the performance.

## Aqueara High Performance Bi-bloc H Generation Three Phase. Heating and Cooling • R410A refrigerant

## WH-UD09HE8

Tamb	HC	IP	COP	HC	IP	COP	HC	IP	COP	HC	IP	COP	HC	IP	COP	HC	IP	COP
LWC	30	30	30	35	35	35	40	40	40	45	45	45	50	50	50	55	55	55
-15	8,65	3,06	2,83	8,30	3,21	2,59	7,95	3,41	2,33	7,60	3,61	2,11	7,15	3,71	1,93	6,70	3,81	1,76
-7	9,35	2,91	3,21	9,00	3,16	2,85	8,85	3,54	2,50	8,70	3,92	2,22	8,30	3,89	2,13	7,90	3,86	2,05
2	9,31	2,35	3,96	9,00	2,51	3,59	9,00	2,78	3,24	9,00	3,05	2,95	8,90	3,49	2,55	8,80	3,94	2,23
7	9,00	1,54	5,84	9,00	1,86	4,84	9,00	2,16	4,17	9,00	2,46	3,66	9,00	2,76	3,26	9,00	3,06	2,94
25	9,00	1,05	8,57	9,00	1,24	7,26	8,73	1,44	6,06	8,46	1,64	5,16	8,28	1,82	4,55	8,10	2,00	4,05

## WH-UD12HE8

Tamb	HC	IP	COP	HC	IP	COP	HC	IP	COP	HC	IP	COP	HC	IP	COP	HC	IP	COP
LWC	30	30	30	35	35	35	40	40	40	45	45	45	50	50	50	55	55	55
-15	9,30	3,46	2,69	8,90	3,62	2,46	8,50	3,79	2,24	8,10	3,95	2,05	7,50	4,05	1,85	7,00	4,16	1,68
-7	10,40	3,37	3,09	10,00	3,66	2,73	9,60	3,95	2,43	9,20	4,24	2,17	8,70	4,26	2,04	8,20	4,27	1,92
2	11,80	3,10	3,81	11,40	3,31	3,44	11,00	3,53	3,12	10,60	3,74	2,83	9,80	3,94	2,49	9,10	4,14	2,20
7	12,00	2,10	5,71	12,00	2,53	4,74	12,00	2,96	4,05	12,00	3,39	3,54	12,00	3,78	3,17	12,00	4,16	2,88
25	12,00	1,38	8,70	12,00	1,66	7,23	11,80	1,94	6,08	11,70	2,23	5,25	11,50	2,49	4,62	11,40	2,74	4,16

## WH-UD16HE8

Tamb	HC	IP	COP	HC	IP	COP	HC	IP	COP	HC	IP	COP	HC	IP	COP	HC	IP	COP
LWC	30	30	30	35	35	35	40	40	40	45	45	45	50	50	50	55	55	55
-15	10,60	4,09	2,59	10,30	4,38	2,35	10,00	4,67	2,14	9,70	4,96	1,96	8,80	4,94	1,78	7,90	4,91	1,61
-7	11,90	4,03	2,95	11,40	4,43	2,57	10,80	4,83	2,24	10,30	5,22	1,97	9,60	5,09	1,89	9,00	4,95	1,82
2	13,50	3,74	3,61	13,00	3,96	3,28	12,40	4,18	2,97	11,90	4,40	2,70	10,80	4,46	2,42	9,80	4,51	2,17
7	16,00	3,21	4,98	16,00	3,74	4,28	16,00	4,27	3,75	16,00	4,80	3,33	15,20	5,11	2,97	14,50	5,41	2,68
25	16,00	2,31	6,93	16,00	2,69	5,95	16,00	3,07	5,21	16,00	3,45	4,64	16,00	3,67	4,36	15,90	3,89	4,09

## Aqueara High Performance Bi-bloc H Generation Three Phase. Heating and Cooling • R410A refrigerant

## WH-UD09HE8

Tamb	CC	IP	EER	CC	IP	EER	CC	IP	EER
LWC	7	7	7	14	14	14	18	18	18
16	7,50	1,15	6,52	9,10	1,20	7,58	7,00	1,13	6,19
25	8,35	1,77	4,72	10,90	1,78	6,12	7,00	1,24	5,65
35	7,00	2,23	3,14	8,30	2,32	3,58	7,00	1,52	4,61
43	5,52	2,54	2,17	7,69	2,77	2,78	5,60	1,80	3,11

## WH-UD12HE8

Tamb	CC	IP	EER	CC	IP	EER	CC	IP	EER
LWC	7	7	7	14	14	14	18	18	18
16	7,86	1,18	6,66	13,15	1,40	9,39	10,00	1,73	5,78
25	12,08	2,90	4,17	15,70	2,05	7,66	10,00	1,97	5,08
35	10,00	2,56	3,91	12,00	2,67	4,49	10,00	2,40	4,17
43	7,80	3,80	2,05	11,10	3,19	3,48	8,00	2,85	2,81

## WH-UD16HE8

Tamb	CC	IP	EER	CC	IP	EER	CC	IP	EER
LWC	7	7	7	14	14	14	18	18	18
16	9,20	1,62	5,68	16,40	2,58	6,36	12,20	2,45	4,98
25	14,40	3,92	3,67	19,20	3,83	5,01	12,20	2,79	4,37
35	12,20	4,76	2,56	15,00	4,98	3,01	12,20	2,96	4,12
43	7,75	3,40	2,28	13,80	5,95	2,32	9,70	4,00	2,43

Tamb: Ambient Temperature (°C). LWC: Leaving Water Condenser Temperature (°C). HC: Heating Capacity (kW). CC: Cooling Capacity (kW). IP: Input power (kW). This data is measured by Panasonic in accordance with EN14511-2 standard. This data is for reference purpose only, and does not guarantee the performance.

# Heating & Cooling capacity tables

Based on outlet temperature and outside temperature.

## Aqueara T-CAP Bi-bloc H Generation Single Phase / Three Phase. Heating and Cooling • R410A refrigerant

WH-UX09HE5																		
Tamb	HC	IP	COP	HC	IP	COP	HC	IP	COP	HC	IP	COP	HC	IP	COP	HC	IP	COP
LWC	30	30	30	35	35	35	40	40	40	45	45	45	50	50	50	55	55	55
-15	9,00	3,24	2,78	9,00	3,51	2,56	9,00	3,91	2,30	9,00	4,30	2,09	9,00	4,73	1,90	9,00	5,16	1,74
-7	9,00	2,71	3,32	9,00	3,16	2,85	9,00	3,62	2,49	9,00	4,07	2,21	9,00	4,27	2,11	9,00	4,46	2,02
2	9,00	2,36	3,81	9,00	2,51	3,59	9,00	2,78	3,24	9,00	3,05	2,95	9,00	3,56	2,53	9,00	4,07	2,21
7	9,00	1,64	5,49	9,00	1,86	4,84	9,00	2,16	4,17	9,00	2,46	3,66	9,00	2,76	3,26	9,00	3,06	2,94
25	13,60	1,50	9,07	13,60	1,71	7,95	13,20	1,93	6,84	12,80	2,14	5,98	12,00	2,41	4,98	11,20	2,67	4,19
WH-UX12HE5																		
Tamb	HC	IP	COP	HC	IP	COP	HC	IP	COP	HC	IP	COP	HC	IP	COP	HC	IP	COP
LWC	30	30	30	35	35	35	40	40	40	45	45	45	50	50	50	55	55	55
-15	12,00	4,75	2,53	12,00	4,96	2,42	12,00	5,41	2,22	11,00	5,38	2,04	10,80	5,82	1,86	10,50	6,26	1,68
-7	12,00	3,85	3,12	12,00	4,41	2,72	12,00	4,98	2,41	12,00	5,54	2,17	12,00	5,90	2,03	12,00	6,26	1,92
2	12,00	3,19	3,76	12,00	3,49	3,44	12,00	3,87	3,10	12,00	4,25	2,82	12,00	4,86	2,47	12,00	5,47	2,19
7	12,00	2,18	5,50	12,00	2,53	4,74	12,00	2,96	4,05	12,00	3,39	3,54	12,00	3,78	3,17	12,00	4,16	2,88
25	13,60	1,55	8,77	13,60	1,76	7,73	13,40	2,10	6,38	13,20	2,43	5,43	12,60	2,66	4,74	12,00	2,89	4,15
WH-UX09HE8																		
Tamb	HC	IP	COP	HC	IP	COP	HC	IP	COP	HC	IP	COP	HC	IP	COP	HC	IP	COP
LWC	30	30	30	35	35	35	40	40	40	45	45	45	50	50	50	55	55	55
-15	9,00	3,24	2,78	9,00	3,51	2,56	9,00	3,91	2,30	9,00	4,30	2,09	9,00	4,73	1,90	9,00	5,16	1,74
-7	9,00	2,71	3,32	9,00	3,16	2,85	9,00	3,62	2,49	9,00	4,07	2,21	9,00	4,27	2,11	9,00	4,46	2,02
2	9,00	2,36	3,81	9,00	2,51	3,59	9,00	2,78	3,24	9,00	3,05	2,95	9,00	3,56	2,53	9,00	4,07	2,21
7	9,00	1,64	5,49	9,00	1,86	4,84	9,00	2,16	4,17	9,00	2,46	3,66	9,00	2,76	3,26	9,00	3,06	2,94
25	13,60	1,50	9,07	13,60	1,71	7,95	13,20	1,93	6,84	12,80	2,14	5,98	12,00	2,41	4,98	11,20	2,67	4,19
WH-UX12HE8																		
Tamb	HC	IP	COP	HC	IP	COP	HC	IP	COP	HC	IP	COP	HC	IP	COP	HC	IP	COP
LWC	30	30	30	35	35	35	40	40	40	45	45	45	50	50	50	55	55	55
-15	12,00	4,75	2,53	12,00	4,96	2,42	12,00	5,41	2,22	12,00	5,86	2,05	11,80	6,24	1,89	11,60	6,62	1,75
-7	12,00	3,85	3,12	12,00	4,41	2,72	12,00	4,98	2,41	12,00	5,54	2,17	12,00	5,90	2,03	12,00	6,26	1,92
2	12,00	3,19	3,76	12,00	3,49	3,44	12,00	3,87	3,10	12,00	4,25	2,82	12,00	4,86	2,47	12,00	5,47	2,19
7	12,00	2,18	5,50	12,00	2,53	4,74	12,00	2,96	4,05	12,00	3,39	3,54	12,00	3,78	3,17	12,00	4,16	2,88
25	13,60	1,55	8,77	13,60	1,76	7,73	13,40	2,10	6,38	13,20	2,43	5,43	12,60	2,66	4,74	12,00	2,89	4,15
WH-UX16HE8																		
Tamb	HC	IP	COP	HC	IP	COP	HC	IP	COP	HC	IP	COP	HC	IP	COP	HC	IP	COP
LWC	30	30	30	35	35	35	40	40	40	45	45	45	50	50	50	55	55	55
-15	16,00	6,30	2,54	16,00	6,89	2,32	16,00	7,45	2,15	16,00	8,10	1,98	16,00	8,48	1,89	15,20	8,96	1,70
-7	16,00	5,85	2,74	16,00	6,42	2,49	16,00	7,00	2,29	16,00	7,57	2,11	16,00	8,10	1,98	16,00	8,62	1,86
2	16,00	4,67	3,43	16,00	5,21	3,07	16,00	5,74	2,79	16,00	6,31	2,54	16,00	6,90	2,32	16,00	7,50	2,13
7	16,00	3,35	4,78	16,00	3,74	4,28	16,00	4,30	3,72	16,00	4,80	3,33	16,00	5,43	2,95	16,00	5,91	2,71
16	16,00	2,59	6,18	16,00	3,18	5,03	16,00	3,71	4,31	16,00	4,27	3,75	16,00	4,86	3,29	16,00	5,22	3,07
25	16,00	2,02	7,92	16,00	2,58	6,20	16,00	2,91	5,50	16,00	3,36	4,76	16,00	3,74	4,28	16,00	4,00	4,00

## Aqueara T-CAP Bi-bloc H Generation Single Phase / Three Phase. Heating and Cooling • R410A refrigerant

Models		WH-UX09HE5									WH-UX12HE5								
Tamb	CC	IP	EER	CC	IP	EER	CC	IP	EER	CC	IP	EER	CC	IP	EER	CC	IP	EER	
LWC	7	7	7	14	14	14	18	18	18	7	7	7	14	14	14	18	18	18	
18	7,00	1,36	5,15	8,55	1,41	6,06	7,00	1,00	7,00	10,00	1,75	5,71	13,20	1,96	6,73	10,00	1,40	7,14	
25	7,65	1,91	4,01	11,10	1,98	5,61	7,00	1,10	6,36	11,20	2,67	4,19	16,50	3,01	5,48	10,00	1,60	6,25	
35	7,00	2,21	3,17	9,23	2,37	3,89	7,00	1,35	5,19	10,00	3,56	2,81	12,55	3,63	3,46	10,00	1,95	5,13	
43	6,25	2,66	2,35	8,55	2,71	3,15	5,60	1,60	3,50	8,00	3,35	2,39	10,00	3,46	2,89	8,00	2,30	3,48	
Models		WH-UX09HE8						WH-UX12HE8						WH-UX16HE8					
Tamb	CC	IP	EER	CC	IP	EER	CC	IP	EER	CC	IP	EER	CC	IP	EER	CC	IP	EER	
LWC	7	7	7	18	18	18	7	7	7	18	18	18	7	7	7	18	18	18	
18	7,00	1,36	5,15	—	—	—	7,50	1,41	5,32	—	—	—	8,50	1,70	5,00	10,00	1,70	5,88	
25	7,65	1,91	4,01	—	—	—	8,90	2,16	4,12	—	—	—	14,00	4,00	3,50	14,00	2,94	4,76	
35	7,00	2,21	3,17	—	—	—	10,00	3,56	2,81	—	—	—	12,20	4,76	2,56	12,20	3,50	3,49	
43	6,25	2,66	2,35	—	—	—	8,00	3,01	2,66	—	—	—	7,10	3,31	2,15	9,80	3,31	2,96	

Tamb: Ambient Temperature (°C). LWC: Leaving Water Condenser Temperature (°C). HC: Heating Capacity (kW). CC: Cooling Capacity (kW). IP: Input power (kW). This data is measured by Panasonic in accordance with EN14511-2 standard. This data is for reference purpose only, and does not guarantee the performance.

**Aquarea T-CAP Bi-bloc H Generation Three Phase. Super Quiet outdoor unit. Heating and Cooling - SQC • R410A refrigerant**
**WH-UQ09HE8**

Tamb	HC	IP	COP	HC	IP	COP	HC	IP	COP	HC	IP	COP	HC	IP	COP	HC	IP	COP
LWC	30	30	30	35	35	35	40	40	40	45	45	45	50	50	50	55	55	55
-15	9,00	3,24	2,78	9,00	3,51	2,56	9,00	3,91	2,30	9,00	4,30	2,09	9,00	4,73	1,90	9,00	5,16	1,74
-7	9,00	2,71	3,32	9,00	3,16	2,85	9,00	3,62	2,49	9,00	4,07	2,21	9,00	4,27	2,11	9,00	4,46	2,02
2	9,00	2,36	3,81	9,00	2,51	3,59	9,00	2,78	3,24	9,00	3,05	2,95	9,00	3,56	2,53	9,00	4,07	2,21
7	9,00	1,64	5,49	9,00	1,86	4,84	9,00	2,16	4,17	9,00	2,46	3,66	9,00	2,76	3,26	9,00	3,06	2,94
25	13,60	1,50	9,07	13,60	1,71	7,95	13,20	1,93	6,84	12,80	2,14	5,98	12,00	2,41	4,98	11,20	2,67	4,19

**WH-UQ12HE8**

Tamb	HC	IP	COP	HC	IP	COP	HC	IP	COP	HC	IP	COP	HC	IP	COP	HC	IP	COP
LWC	30	30	30	35	35	35	40	40	40	45	45	45	50	50	50	55	55	55
-15	12,00	4,75	2,53	12,00	4,96	2,42	12,00	5,41	2,22	12,00	5,86	2,05	11,80	6,24	1,89	11,60	6,62	1,75
-7	12,00	3,85	3,12	12,00	4,41	2,72	12,00	4,98	2,41	12,00	5,54	2,17	12,00	5,90	2,03	12,00	6,26	1,92
2	12,00	3,19	3,76	12,00	3,49	3,44	12,00	3,87	3,10	12,00	4,25	2,82	12,00	4,86	2,47	12,00	5,47	2,19
7	12,00	2,18	5,50	12,00	2,53	4,74	12,00	2,96	4,05	12,00	3,39	3,54	12,00	3,78	3,17	12,00	4,16	2,88
25	13,60	1,55	8,77	13,60	1,76	7,73	13,40	2,10	6,38	13,20	2,43	5,43	12,60	2,66	4,74	12,00	2,89	4,15

**WH-UQ16HE8**

Tamb	HC	IP	COP	HC	IP	COP	HC	IP	COP	HC	IP	COP	HC	IP	COP	HC	IP	COP
LWC	30	30	30	35	35	35	40	40	40	45	45	45	50	50	50	55	55	55
-15	16,00	6,30	2,54	16,00	6,89	2,32	16,00	7,45	2,15	16,00	8,10	1,98	16,00	8,48	1,89	15,20	8,96	1,70
-7	16,00	5,85	2,74	16,00	6,42	2,49	16,00	7,00	2,29	16,00	7,57	2,11	16,00	8,10	1,98	16,00	8,62	1,86
2	16,00	4,67	3,43	16,00	5,21	3,07	16,00	5,74	2,79	16,00	6,31	2,54	16,00	6,90	2,32	16,00	7,50	2,13
7	16,00	3,35	4,78	16,00	3,74	4,28	16,00	4,30	3,72	16,00	4,80	3,33	16,00	5,43	2,95	16,00	5,91	2,71
16	16,00	2,59	6,18	16,00	3,18	5,03	16,00	3,71	4,31	16,00	4,27	3,75	16,00	4,86	3,29	16,00	5,22	3,07
25	16,00	2,02	7,92	16,00	2,58	6,20	16,00	2,91	5,50	16,00	3,36	4,76	16,00	3,74	4,28	16,00	4,00	4,00

**Aquarea T-CAP Bi-bloc H Generation Three Phase. Super Quiet outdoor unit. Heating and Cooling - SQC • R410A refrigerant**
**WH-UQ09HE8**

Tamb	CC	IP	EER	CC	IP	EER
LWC	7	7	7	18	18	18
18	7,00	1,36	5,15	—	—	—
25	7,65	1,91	4,01	—	—	—
35	7,00	2,21	3,17	—	—	—
43	6,25	2,66	2,35	—	—	—

**WH-UQ12HE8**

Tamb	CC	IP	EER	CC	IP	EER
LWC	7	7	7	18	18	18
18	7,50	1,41	5,32	—	—	—
25	8,90	2,16	4,12	—	—	—
35	10,00	3,56	2,81	—	—	—
43	8,00	3,01	2,66	—	—	—

**WH-UQ16HE8**

Tamb	CC	IP	EER	CC	IP	EER
LWC	7	7	7	18	18	18
18	8,50	1,70	5,00	10,00	1,70	5,88
25	14,00	4,00	3,50	14,00	2,94	4,76
35	12,20	4,76	2,56	12,20	3,50	3,49
43	7,10	3,31	2,15	9,80	3,31	2,96

Tamb: Ambient Temperature (°C). LWC: Leaving Water Condenser Temperature (°C). HC: Heating Capacity (kW). CC: Cooling Capacity (kW). IP: Input power (kW). This data is measured by Panasonic in accordance with EN14511-2 standard. This data is for reference purpose only, and does not guarantee the performance.

# Heating & Cooling capacity tables

Based on outlet temperature and outside temperature.

## Aquarea High Performance Mono-bloc J Generation Single Phase. Heating and Cooling - MDC • R32 refrigerant

WH-MDC05J3E5																
Tamb	HC	IP	COP	HC	IP	COP	HC	IP	COP	HC	IP	COP	HC	IP	COP	
LWC	25	25	25	35	35	35	45	45	45	55	55	55	60	60	60	
-20	4,37	1,73	2,53	4,16	2,03	2,05	3,84	2,37	1,62	3,43	2,64	1,30	—	—	—	
-15	5,13	1,78	2,88	5,00	2,17	2,30	4,75	2,51	1,89	3,70	2,45	1,51	—	—	—	
-7	5,17	1,49	3,47	5,00	1,80	2,78	4,80	2,16	2,22	5,00	2,70	1,85	4,68	2,71	1,73	
2	5,00	1,11	4,50	5,00	1,40	3,57	5,00	1,81	2,76	5,00	2,20	2,27	4,80	2,40	2,00	
7	5,09	0,78	6,53	5,00	0,99	5,05	5,00	1,31	3,82	5,00	1,66	3,01	4,58	1,90	2,41	
25	4,96	0,77	6,44	5,04	0,90	5,60	5,31	1,16	4,58	5,61	1,34	4,19	5,15	1,33	3,87	
WH-MDC07J3E5																
Tamb	HC	IP	COP	HC	IP	COP	HC	IP	COP	HC	IP	COP	HC	IP	COP	
LWC	25	25	25	35	35	35	45	45	45	55	55	55	60	60	60	
-20	4,86	2,03	2,39	4,66	2,35	1,98	4,44	2,75	1,61	4,23	3,13	1,35	—	—	—	
-15	5,80	2,11	2,75	5,60	2,40	2,33	5,30	2,84	1,87	5,00	3,32	1,51	—	—	—	
-7	6,76	2,07	3,27	6,80	2,42	2,81	6,30	2,82	2,23	6,30	3,39	1,86	4,74	2,76	1,72	
2	6,83	1,66	4,11	7,00	2,06	3,40	6,85	2,50	2,74	6,30	2,92	2,16	4,80	2,40	2,00	
7	7,32	1,19	6,15	7,00	1,47	4,76	7,00	1,96	3,57	7,00	2,48	2,82	6,18	2,44	2,53	
25	6,80	0,64	10,63	6,67	0,93	7,17	6,79	1,38	4,92	6,70	1,80	3,72	6,22	1,78	3,49	
WH-MDC09J3E5																
Tamb	HC	IP	COP	HC	IP	COP	HC	IP	COP	HC	IP	COP	HC	IP	COP	
LWC	25	25	25	35	35	35	45	45	45	55	55	55	60	60	60	
-20	5,33	2,36	2,26	6,43	3,60	1,79	5,78	3,83	1,51	4,83	3,64	1,33	—	—	—	
-15	7,76	3,20	2,43	7,60	3,41	2,23	7,00	3,71	1,89	5,60	3,80	1,47	—	—	—	
-7	7,39	2,45	3,02	7,50	2,85	2,63	7,30	3,37	2,17	7,00	3,89	1,80	6,44	3,67	1,75	
2	7,38	1,89	3,90	7,45	2,38	3,13	7,00	2,85	2,46	7,00	3,30	2,12	5,46	2,72	2,01	
7	9,15	1,59	5,75	9,00	2,01	4,48	9,00	2,61	3,45	8,95	3,22	2,78	7,25	2,87	2,53	
25	8,02	0,98	8,18	7,88	1,32	5,97	8,46	1,86	4,55	7,60	2,03	3,74	6,30	1,87	3,37	

## Aquarea High Performance Mono-bloc J Generation Single Phase. Heating and Cooling - MDC • R32 refrigerant

WH-MDC05J3E5									
Tamb	CC	IP	EER	CC	IP	EER	CC	IP	EER
LWC	7	7	7	14	14	14	18	18	18
16	5,18	0,82	6,32	6,17	0,84	7,35	5,78	0,60	9,63
25	5,38	1,22	4,41	6,64	1,25	5,31	5,55	0,78	7,12
35	5,00	1,54	3,25	5,86	1,61	3,64	5,00	0,99	5,05
43	4,19	1,85	2,26	5,36	1,92	2,79	4,37	1,30	3,36
WH-MDC07J3E5									
Tamb	CC	IP	EER	CC	IP	EER	CC	IP	EER
LWC	7	7	7	14	14	14	18	18	18
16	5,38	0,83	6,48	6,69	0,85	7,87	7,65	0,76	10,07
25	6,96	1,82	3,82	9,06	1,98	4,58	7,58	1,23	6,16
35	7,00	2,29	3,06	8,37	2,47	3,39	7,00	1,48	4,73
43	5,60	2,55	2,20	6,87	2,58	2,66	6,10	1,88	3,24
WH-MDC09J3E5									
Tamb	CC	IP	EER	CC	IP	EER	CC	IP	EER
LWC	7	7	7	14	14	14	18	18	18
16	6,89	1,21	5,69	8,65	1,23	7,03	9,82	1,19	8,25
25	9,50	2,84	3,35	11,55	3,06	3,77	9,68	1,82	5,32
35	9,00	3,32	2,71	10,10	3,51	2,88	9,00	2,12	4,25
43	5,42	2,56	2,12	6,56	2,56	2,56	7,40	2,56	2,89

Tamb: Ambient Temperature (°C). LWC: Leaving Water Condenser Temperature (°C). HC: Heating Capacity (kW). CC: Cooling Capacity (kW). IP: Input power (kW). This data is measured by Panasonic in accordance with EN14511-2 standard. This data is for reference purpose only, and does not guarantee the performance.



## Aquarea High Performance Mono-bloc H Generation Single Phase. Heating and Cooling - MDC • R410A refrigerant

## WH-MDC05H3E5

Tamb	HC	IP	COP	HC	IP	COP	HC	IP	COP	HC	IP	COP	HC	IP	COP	HC	IP	COP
LWC	30	30	30	35	35	35	40	40	40	45	45	45	50	50	50	55	55	55
-15	5,13	2,02	2,54	5,00	2,20	2,27	4,88	2,39	2,04	4,75	2,57	1,85	4,08	2,29	1,78	3,40	2,00	1,70
-7	4,80	1,49	3,23	4,70	1,65	2,85	4,60	1,82	2,53	4,50	1,98	2,27	4,40	2,13	2,07	4,30	2,28	1,89
2	5,10	1,34	3,81	4,80	1,43	3,36	4,50	1,52	2,96	4,20	1,61	2,61	4,10	1,67	2,46	4,00	1,72	2,33
7	5,00	0,79	6,33	5,00	0,99	5,08	5,00	1,18	4,24	5,00	1,37	3,65	5,00	1,57	3,19	5,00	1,76	2,84
12	4,85	0,77	6,29	4,83	0,89	5,46	4,82	1,00	4,82	4,80	1,12	4,29	4,74	1,25	3,81	4,68	1,37	3,42

## WH-MDC07H3E5

Tamb	HC	IP	COP	HC	IP	COP	HC	IP	COP	HC	IP	COP	HC	IP	COP	HC	IP	COP
LWC	30	30	30	35	35	35	40	40	40	45	45	45	50	50	50	55	55	55
-15	4,60	1,68	2,75	4,60	1,89	2,43	4,60	2,11	2,19	4,60	2,32	1,98	4,55	2,56	1,78	4,50	2,79	1,61
-7	5,60	1,88	2,99	5,50	2,04	2,70	5,40	2,21	2,45	5,30	2,37	2,24	5,15	2,56	2,01	5,00	2,75	1,82
2	6,65	1,79	3,73	6,60	2,00	3,30	6,55	2,22	2,96	6,50	2,43	2,67	6,40	2,64	2,43	6,30	2,84	2,22
7	7,00	1,33	5,28	7,00	1,55	4,52	7,00	1,78	3,94	7,00	2,00	3,50	7,00	2,24	3,13	7,00	2,47	2,83
12	7,00	1,30	5,38	7,00	1,45	4,83	7,05	1,65	4,27	7,10	1,90	3,74	7,15	2,10	3,40	7,20	2,30	3,13

## WH-MDC09H3E5

Tamb	HC	IP	COP	HC	IP	COP	HC	IP	COP	HC	IP	COP	HC	IP	COP	HC	IP	COP
LWC	30	30	30	35	35	35	40	40	40	45	45	45	50	50	50	55	55	55
-15	6,10	2,34	2,61	5,90	2,50	2,36	5,70	2,67	2,14	5,50	2,83	1,94	5,25	2,99	1,76	5,00	3,14	1,59
-7	6,55	2,26	2,90	6,40	2,46	2,60	6,25	2,66	2,35	6,10	2,86	2,13	5,95	3,06	1,95	5,80	3,25	1,78
2	6,85	1,92	3,58	6,80	2,14	3,18	6,75	2,37	2,85	6,70	2,59	2,59	6,50	2,78	2,34	6,30	2,96	2,13
7	9,00	1,80	5,01	9,00	2,10	4,29	9,00	2,41	3,74	9,00	2,71	3,32	9,00	3,01	2,99	9,00	3,31	2,72
12	9,10	1,61	5,65	9,00	1,79	5,03	9,00	2,09	4,31	9,10	2,40	3,79	9,20	2,80	3,29	9,30	3,00	3,10

## WH-MDC12H6E5

Tamb	HC	IP	COP	HC	IP	COP	HC	IP	COP	HC	IP	COP	HC	IP	COP	HC	IP	COP
LWC	30	30	30	35	35	35	40	40	40	45	45	45	50	50	50	55	55	55
-15	9,30	3,46	2,69	8,90	3,62	2,46	8,50	3,79	2,24	8,10	3,95	2,05	—	—	—	7,00	4,10	1,71
-7	10,40	3,37	3,09	10,00	3,66	2,73	9,60	3,95	2,43	9,20	4,24	2,17	—	—	—	8,20	4,21	1,95
2	11,80	3,10	3,81	11,40	3,31	3,44	11,00	3,53	3,12	10,60	3,74	2,83	—	—	—	9,10	4,08	2,23
7	12,00	2,10	5,71	12,00	2,53	4,74	12,00	2,96	4,05	12,00	3,39	3,54	—	—	—	12,00	4,10	2,93
12	12,00	1,38	8,70	12,00	1,66	7,23	11,80	1,94	6,08	11,70	2,23	5,25	—	—	—	11,40	2,74	4,16

## WH-MDC16H6E5

Tamb	HC	IP	COP	HC	IP	COP	HC	IP	COP	HC	IP	COP	HC	IP	COP	HC	IP	COP
LWC	30	30	30	35	35	35	40	40	40	45	45	45	50	50	50	55	55	55
-15	10,60	4,09	2,59	10,30	4,38	2,35	10,00	4,67	2,14	9,70	4,96	1,96	7,90	4,84	1,63	—	—	—
-7	11,90	4,03	2,95	11,40	4,43	2,57	10,80	4,83	2,24	10,30	5,22	1,97	9,00	4,88	1,84	—	—	—
2	13,50	13,74	0,98	13,00	3,96	3,28	12,40	4,18	2,97	11,90	4,40	2,70	9,80	4,44	2,21	—	—	—
7	16,00	3,21	4,98	16,00	3,74	4,28	16,00	4,27	3,75	16,00	4,80	3,33	14,50	5,33	2,72	—	—	—
12	16,00	2,31	6,93	16,00	2,69	5,95	16,00	3,07	5,21	16,00	3,45	4,64	15,90	3,89	4,09	—	—	—

Tamb: Ambient Temperature [°C]. LWC: Leaving Water Condenser Temperature [°C]. HC: Heating Capacity (kW). CC: Cooling Capacity (kW). IP: Input power (kW). This data is measured by Panasonic in accordance with EN14511-2 standard. This data is for reference purpose only, and does not guarantee the performance.

# Heating & Cooling capacity tables

Based on outlet temperature and outside temperature.

## Aquarea High Performance Mono-bloc H Generation Single Phase. Heating and Cooling - MDC • R410A refrigerant

### WH-MDC05H3E5

Tamb	CC	IP	EER	CC	IP	EER	CC	IP	EER
LWC	7	7	7	14	14	14	18	18	18
24	5,15	1,06	4,86	6,45	1,05	6,14	5,90	0,73	8,08
35	4,50	1,37	3,28	5,52	1,36	4,06	5,10	1,00	5,10
43	3,74	1,55	2,41	4,65	1,60	2,91	4,25	1,20	3,54

### WH-MDC07H3E5

Tamb	CC	IP	EER	CC	IP	EER	CC	IP	EER
LWC	7	7	7	14	14	14	18	18	18
24	6,85	1,78	3,85	8,15	1,80	4,53	7,10	1,20	5,92
35	6,00	2,16	2,78	5,35	1,53	3,51	6,00	1,55	3,87
43	4,90	2,48	1,98	4,45	1,80	2,47	5,10	1,85	2,76

### WH-MDC09H3E5

Tamb	CC	IP	EER	CC	IP	EER	CC	IP	EER
LWC	7	7	7	14	14	14	18	18	18
24	7,30	1,92	3,80	8,60	1,98	4,34	8,20	1,55	5,29
35	7,00	2,69	2,60	6,40	1,93	3,32	7,00	1,95	3,59
43	5,25	2,84	1,85	5,40	2,25	2,40	6,00	2,30	2,61

### WH-MDC12H6E5

Tamb	CC	IP	EER	CC	IP	EER	CC	IP	EER
LWC	7	7	7	14	14	14	18	18	18
16	7,86	1,18	6,66	13,15	2,05	6,41	10,00	1,73	5,78
25	12,08	2,90	4,17	15,70	3,05	5,15	10,00	1,97	5,08
35	10,00	3,56	2,81	12,00	3,67	3,27	10,00	2,15	4,65
43	7,80	3,80	2,05	11,10	3,19	3,48	8,00	2,85	2,81

### WH-MDC16H6E5

Tamb	CC	IP	EER	CC	IP	EER	CC	IP	EER
LWC	7	7	7	14	14	14	18	18	18
16	9,20	1,62	5,68	16,40	2,58	6,36	12,20	2,45	4,98
25	14,40	3,92	3,67	19,20	3,83	5,01	12,20	2,79	4,37
35	12,20	4,76	2,56	15,00	4,98	3,01	12,20	2,96	4,12
43	7,75	3,40	2,28	13,80	5,95	2,32	9,70	4,00	2,43

Tamb: Ambient Temperature (°C). LWC: Leaving Water Condenser Temperature (°C). HC: Heating Capacity (kW). CC: Cooling Capacity (kW). IP: Input power (kW). This data is measured by Panasonic in accordance with EN14511-2 standard. This data is for reference purpose only, and does not guarantee the performance.

## Aquarea T-CAP Mono-bloc H Generation Single Phase / Three Phase. Heating and Cooling - MXC • R410A refrigerant

## WH-MXC09H3E5 / WH-MXC09H3E8

Tamb	HC	IP	COP	HC	IP	COP	HC	IP	COP	HC	IP	COP	HC	IP	COP	HC	IP	COP
LWC	30	30	30	35	35	35	40	40	40	45	45	45	50	50	50	55	55	55
-15	9,00	3,24	2,78	9,00	3,51	2,56	9,00	3,91	2,30	9,00	4,30	2,09	9,00	4,73	1,90	9,00	5,16	1,74
-7	9,00	2,71	3,32	9,00	3,16	2,85	9,00	3,62	2,49	9,00	4,07	2,21	9,00	4,27	2,11	9,00	4,46	2,02
2	9,00	2,36	3,81	9,00	2,51	3,59	9,00	2,78	3,24	9,00	3,05	2,95	9,00	3,56	2,53	9,00	4,07	2,21
7	9,00	1,64	5,49	9,00	1,86	4,84	9,00	2,16	4,17	9,00	2,46	3,66	9,00	2,76	3,26	9,00	3,06	2,94
25	13,60	1,50	9,07	13,60	1,71	7,95	13,20	1,93	6,84	12,80	2,14	5,98	12,00	2,41	4,98	11,20	2,67	4,19

## WH-MXC12H6E5

Tamb	HC	IP	COP	HC	IP	COP	HC	IP	COP	HC	IP	COP	HC	IP	COP	HC	IP	COP
LWC	30	30	30	35	35	35	40	40	40	45	45	45	50	50	50	55	55	55
-15	12,00	4,75	2,53	12,00	4,96	2,42	12,00	5,41	2,22	11,00	5,38	2,04	10,80	5,82	1,86	10,50	6,26	1,68
-7	12,00	3,85	3,12	12,00	4,41	2,72	12,00	4,98	2,41	12,00	5,54	2,17	12,00	5,90	2,03	12,00	6,26	1,92
2	12,00	3,19	3,76	12,00	3,49	3,44	12,00	3,87	3,10	12,00	4,25	2,82	12,00	4,86	2,47	12,00	5,47	2,19
7	12,00	2,18	5,50	12,00	2,53	4,74	12,00	2,96	4,05	12,00	3,39	3,54	12,00	3,78	3,17	12,00	4,16	2,88
25	13,60	1,55	8,77	13,60	1,76	7,73	13,40	2,10	6,38	13,20	2,43	5,43	12,60	2,66	4,74	12,00	2,89	4,15

## WH-MXC12H9E8

Tamb	HC	IP	COP	HC	IP	COP	HC	IP	COP	HC	IP	COP	HC	IP	COP	HC	IP	COP
LWC	30	30	30	35	35	35	40	40	40	45	45	45	50	50	50	55	55	55
-15	12,00	4,75	2,53	12,00	4,96	2,42	12,00	5,41	2,22	12,00	5,86	2,05	11,80	6,24	1,89	11,60	6,62	1,75
-7	12,00	3,85	3,12	12,00	4,41	2,72	12,00	4,98	2,41	12,00	5,54	2,17	12,00	5,90	2,03	12,00	6,26	1,92
2	12,00	3,19	3,76	12,00	3,49	3,44	12,00	3,87	3,10	12,00	4,25	2,82	12,00	4,86	2,47	12,00	5,47	2,19
7	12,00	2,18	5,50	12,00	2,53	4,74	12,00	2,96	4,05	12,00	3,39	3,54	12,00	3,78	3,17	12,00	4,16	2,88
25	13,60	1,55	8,77	13,60	1,76	7,73	13,40	2,10	6,38	13,20	2,43	5,43	12,60	2,66	4,74	12,00	2,89	4,15

## WH-MXC16H9E8

Tamb	HC	IP	COP	HC	IP	COP	HC	IP	COP	HC	IP	COP	HC	IP	COP	HC	IP	COP
LWC	30	30	30	35	35	35	40	40	40	45	45	45	50	50	50	55	55	55
-15	16,00	6,30	2,54	16,00	6,89	2,32	16,00	7,45	2,15	16,00	8,10	1,98	16,00	8,48	1,89	15,20	8,96	1,70
-7	16,00	5,85	2,74	16,00	6,42	2,49	16,00	7,00	2,29	16,00	7,57	2,11	16,00	8,10	1,98	16,00	8,62	1,86
2	16,00	4,67	3,43	16,00	5,21	3,07	16,00	5,74	2,79	16,00	6,31	2,54	16,00	6,90	2,32	16,00	7,50	2,13
7	16,00	3,35	4,78	16,00	3,74	4,28	16,00	4,30	3,72	16,00	4,80	3,33	16,00	5,43	2,95	16,00	5,91	2,71
16	16,00	2,59	6,18	16,00	3,18	5,03	16,00	3,71	4,31	16,00	4,27	3,75	16,00	4,86	3,29	16,00	5,22	3,07
25	16,00	2,02	7,92	16,00	2,58	6,20	16,00	2,91	5,50	16,00	3,36	4,76	16,00	3,74	4,28	16,00	4,00	4,00

## Aquarea T-CAP Mono-bloc H Generation Single Phase / Three Phase. Heating and Cooling - MXC • R410A refrigerant

Models	WH-MXC09H3E5									WH-MXC12H6E5								
	Tamb	CC	IP	EER	CC	IP	EER	CC	IP	EER	CC	IP	EER	CC	IP	EER	CC	IP
LWC	7	7	7	14	14	14	18	18	18	7	7	7	14	14	14	18	18	18
18	7,00	1,36	5,15	8,55	1,41	6,06	7,00	1,00	7,00	10,00	1,75	5,71	13,20	1,96	6,73	10,00	1,40	7,14
25	7,65	1,91	4,01	11,10	1,98	5,61	7,00	1,10	6,36	11,20	2,67	4,19	16,50	3,01	5,48	10,00	1,60	6,25
35	7,00	2,21	3,17	9,23	2,37	3,89	7,00	1,35	5,19	10,00	3,56	2,81	12,55	3,63	3,46	10,00	1,95	5,13
43	6,25	2,66	2,35	8,55	2,71	3,15	5,60	1,60	3,50	8,00	3,35	2,39	10,00	3,46	2,89	8,00	2,30	3,48
Models	WH-MXC09H3E8						WH-MXC12H9E8						WH-MXC16H9E8					
	Tamb	CC	IP	EER	CC	IP	EER	CC	IP	EER	CC	IP	EER	CC	IP	EER	CC	IP
LWC	7	7	7	18	18	18	7	7	7	18	18	18	7	7	7	18	18	18
18	7,00	1,36	5,15	—	—	—	7,50	1,41	5,32	—	—	—	8,50	1,70	5,00	10,00	1,70	5,88
25	7,65	1,91	4,01	—	—	—	8,90	2,16	4,12	—	—	—	14,00	4,00	3,50	14,00	2,94	4,76
35	7,00	2,21	3,17	—	—	—	10,00	3,56	2,81	—	—	—	12,20	4,76	2,56	12,20	3,50	3,49
43	6,25	2,66	2,35	—	—	—	8,00	3,01	2,66	—	—	—	7,10	3,31	2,15	9,80	3,31	2,96

Tamb: Ambient Temperature (°C). LWC: Leaving Water Condenser Temperature (°C). HC: Heating Capacity (kW). CC: Cooling Capacity (kW). IP: Input power (kW). This data is measured by Panasonic in accordance with EN14511-2 standard. This data is for reference purpose only, and does not guarantee the performance.

# Heating & Cooling capacity tables

Based on outlet temperature and outside temperature.

## Aquarea HT Bi-bloc F Generation Single Phase / Three Phase. Heating Only • R407C refrigerant

### WH-UH09FE5

Tamb	HC	IP	COP	HC	IP	COP	HC	IP	COP	HC	IP	COP	HC	IP	COP	HC	IP	COP	HC	IP	COP	HC	IP	COP
LWC	30	30	30	35	35	35	40	40	40	45	45	45	50	50	50	55	55	55	60	60	60	65	65	65
-15	9,00	3,46	2,60	9,00	3,71	2,43	9,00	4,01	2,24	8,80	4,26	2,07	8,60	4,61	1,87	8,50	4,91	1,73	8,00	5,06	1,58	7,80	5,86	1,33
-7	9,00	3,06	2,94	9,00	3,29	2,74	9,00	3,56	2,53	8,90	3,83	2,32	8,90	4,11	2,17	8,90	4,46	2,00	8,90	4,96	1,79	8,90	5,46	1,63
2	9,00	2,43	3,70	9,00	2,61	3,45	9,00	2,91	3,09	9,00	3,21	2,80	9,00	3,55	2,54	9,00	3,88	2,32	9,00	4,35	2,07	9,00	4,76	1,89
7	9,00	1,82	4,95	9,00	1,94	4,64	9,00	2,21	4,07	9,00	2,46	3,66	9,00	2,76	3,26	9,00	3,06	2,94	9,00	3,46	2,60	9,00	3,96	2,27
16	9,00	1,46	6,16	9,00	1,56	5,77	9,00	1,81	4,97	8,90	2,02	4,41	8,80	2,31	3,81	8,60	2,52	3,41	8,20	2,77	2,96	8,20	3,18	2,58
25	12,00	1,66	7,23	12,00	1,76	6,82	12,00	2,01	5,97	10,80	2,14	5,05	10,60	2,46	4,31	10,20	2,66	3,83	9,80	2,89	3,39	9,60	3,31	2,90

### WH-UH12FE5

Tamb	HC	IP	COP	HC	IP	COP	HC	IP	COP	HC	IP	COP	HC	IP	COP	HC	IP	COP	HC	IP	COP	HC	IP	COP
LWC	30	30	30	35	35	35	40	40	40	45	45	45	50	50	50	55	55	55	60	60	60	65	65	65
-15	12,00	5,16	2,33	12,00	5,53	2,17	11,00	5,51	2,00	10,60	5,53	1,92	10,30	5,63	1,83	9,70	5,76	1,68	9,00	6,01	1,50	8,00	6,11	1,31
-7	12,00	4,43	2,71	12,00	4,76	2,52	11,50	4,91	2,34	11,20	5,06	2,21	10,80	5,16	2,09	10,10	5,28	1,91	10,00	5,66	1,77	9,60	5,91	1,62
2	12,00	3,42	3,51	12,00	3,68	3,26	11,50	3,86	2,98	11,30	4,14	2,73	11,00	4,51	2,44	10,80	4,86	2,22	10,65	5,31	2,01	10,30	5,59	1,84
7	12,00	2,52	4,76	12,00	2,69	4,46	12,00	3,06	3,92	12,00	3,44	3,49	12,00	3,81	3,15	12,00	4,28	2,80	12,00	4,76	2,52	12,00	5,41	2,22
16	12,00	2,03	5,91	12,00	2,17	5,53	12,00	2,52	4,76	12,00	2,86	4,20	11,50	3,19	3,61	11,50	3,48	3,30	11,00	3,82	2,88	11,00	4,37	2,52
25	12,00	1,66	7,23	12,00	1,76	6,82	12,00	2,01	5,97	11,80	2,41	4,90	11,20	2,64	4,24	10,80	2,86	3,78	10,50	3,11	3,38	10,30	3,62	2,85

### WH-UH09FE8

Tamb	HC	IP	COP	HC	IP	COP	HC	IP	COP	HC	IP	COP	HC	IP	COP	HC	IP	COP	HC	IP	COP	HC	IP	COP
LWC	30	30	30	35	35	35	40	40	40	45	45	45	50	50	50	55	55	55	60	60	60	65	65	65
-15	9,00	3,46	2,60	9,00	3,71	2,43	9,00	4,01	2,24	8,80	4,26	2,07	8,60	4,61	1,87	8,50	4,91	1,73	8,00	5,06	1,58	7,80	5,86	1,33
-7	9,00	3,06	2,94	9,00	3,29	2,74	9,00	3,56	2,53	8,90	3,83	2,32	8,90	4,11	2,17	8,90	4,46	2,00	8,90	4,96	1,79	8,90	5,46	1,63
2	9,00	2,43	3,70	9,00	2,61	3,45	9,00	2,91	3,09	9,00	3,21	2,80	9,00	3,55	2,54	9,00	3,88	2,32	9,00	4,35	2,07	9,00	4,76	1,89
7	9,00	1,82	4,95	9,00	1,94	4,64	9,00	2,21	4,07	9,00	2,46	3,66	9,00	2,76	3,26	9,00	3,06	2,94	9,00	3,46	2,60	9,00	3,96	2,27
16	9,00	1,46	6,16	9,00	1,56	5,77	9,00	1,81	4,97	8,90	2,02	4,41	8,80	2,31	3,81	8,60	2,52	3,41	8,20	2,77	2,96	8,20	3,18	2,58
25	12,00	1,66	7,23	12,00	1,76	6,82	12,00	2,01	5,97	10,80	2,14	5,05	10,60	2,46	4,31	10,20	2,66	3,83	9,80	2,89	3,39	9,60	3,31	2,90

### WH-UH12FE8

Tamb	HC	IP	COP	HC	IP	COP	HC	IP	COP	HC	IP	COP	HC	IP	COP	HC	IP	COP	HC	IP	COP	HC	IP	COP
LWC	30	30	30	35	35	35	40	40	40	45	45	45	50	50	50	55	55	55	60	60	60	65	65	65
-15	12,00	5,16	2,33	12,00	5,53	2,17	11,00	5,51	2,00	10,60	5,53	1,92	10,30	5,63	1,83	9,70	5,76	1,68	9,00	6,01	1,50	8,00	6,11	1,31
-7	12,00	4,43	2,71	12,00	4,76	2,52	11,50	4,91	2,34	11,20	5,06	2,21	10,80	5,16	2,09	10,10	5,28	1,91	10,00	5,66	1,77	9,60	5,91	1,62
2	12,00	3,42	3,51	12,00	3,68	3,26	11,50	3,86	2,98	11,30	4,14	2,73	11,00	4,51	2,44	10,80	4,86	2,22	10,65	5,31	2,01	10,30	5,59	1,84
7	12,00	2,52	4,76	12,00	2,69	4,46	12,00	3,06	3,92	12,00	3,44	3,49	12,00	3,81	3,15	12,00	4,28	2,80	12,00	4,76	2,52	12,00	5,41	2,22
16	12,00	2,03	5,91	12,00	2,17	5,53	12,00	2,52	4,76	12,00	2,86	4,20	11,50	3,19	3,61	11,50	3,48	3,30	11,00	3,82	2,88	11,00	4,37	2,52
25	12,00	1,66	7,23	12,00	1,76	6,82	12,00	2,01	5,97	11,80	2,41	4,90	11,20	2,64	4,24	10,80	2,86	3,78	10,50	3,11	3,38	10,30	3,62	2,85

## Aquarea HT Mono-bloc G Generation Single Phase. Heating Only - MHF • R407C refrigerant

### WH-MHF09G3E5

Tamb	HC	IP	COP	HC	IP	COP	HC	IP	COP	HC	IP	COP	HC	IP	COP	HC	IP	COP	HC	IP	COP			
LWC	30	30	30	35	35	35	40	40	40	45	45	45	50	50	50	55	55	55	55	55	55			
-15	9,00	3,46	2,60	9,00	3,71	2,43	9,00	4,01	2,24	8,80	4,26	2,07	8,50	4,71	1,80	7,80	5,38	1,45						
-7	9,00	3,06	2,94	9,00	3,29	2,74	9,00	3,56	2,53	8,90	3,83	2,32	8,90	4,28	2,08	9,00	5,02	1,79						
2	9,00	2,43	3,70	9,00	2,61	3,45	9,00	2,91	3,09	9,00	3,21	2,80	9,00	3,72	2,42	9,00	4,37	2,06						
7	9,00	1,82	4,95	9,00	1,94	4,64	9,00	2,21	4,07	9,00	2,46	3,66	9,00	2,99	3,01	9,00	3,64	2,47						
25	9,00	1,52	5,92	9,00	1,70	5,29	9,00	1,88	4,79	9,00	2,16	4,17	9,00	2,63	3,42	9,00	3,20	2,81						

### WH-MHF12G6E5

Tamb	HC	IP	COP	HC	IP	COP	HC	IP	COP	HC	IP	COP	HC	IP	COP	HC	IP	COP	HC	IP	COP			
LWC	30	30	30	35	35	35	40	40	40	45	45	45	50	50	50	55	55	55	55	55	55			
-15	12,00	5,16	2,33	12,00	5,53	2,17	11,00	5,51	2,00	10,80	5,49	1,97	9,70	5,52	1,76	8,00	5,61	1,43						
-7	12,00	4,43	2,71	12,00	4,76	2,52	11,50	4,91	2,34	11,20	5,06	2,21	10,10	5,06	2,00	9,60	5,43	1,77						
2	12,00	3,42	3,51	12,00	3,68	3,26	11,50	3,86	2,98	11,30	4,14	2,73	10,80	4,66	2,32	10,30	5,13	2,01						
7	12,00	2,52	4,76	12,00	2,69	4,46	12,00	3,06	3,92	12,00	3,44	3,49	12,00	4,10	2,93	12,00	4,97	2,41						
25	12,00	2,03	5,91	12,00	2,36	5,08	12,00	2,69	4,46	12,00	3,02	3,97	12,00	3,61	3,32	12,00	4,37	2,75						

Tamb: Ambient Temperature (°C). LWC: Leaving Water Condenser Temperature (°C). HC: Heating Capacity (kW). CC: Cooling Capacity (kW). IP: Input power (kW). This data is measured by Panasonic in accordance with EN14511-2 standard. This data is for reference purpose only, and does not guarantee the performance.

# Examples of installations

**Aquarea J and H Generation:**  
Bivalent with buffer tank and mixing valve

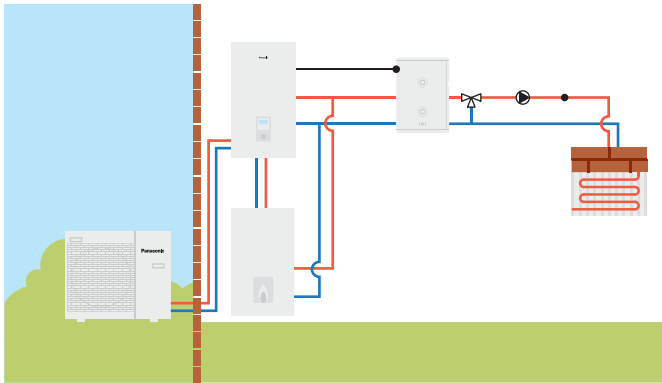

**Aquarea J and H Generation:**  
Buffer tank with solar and mixing valve

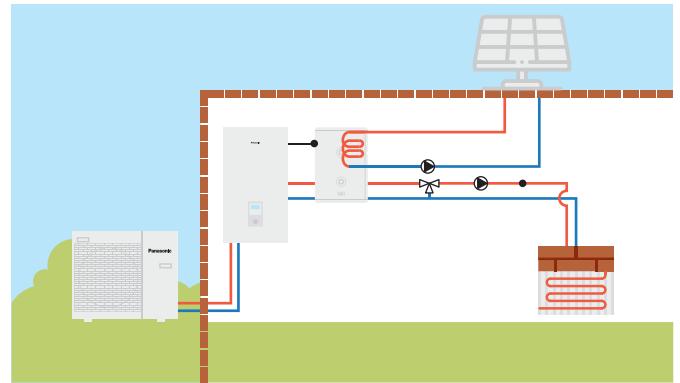

**Aquarea J and H Generation:**  
2 zones with external kit without buffer tank

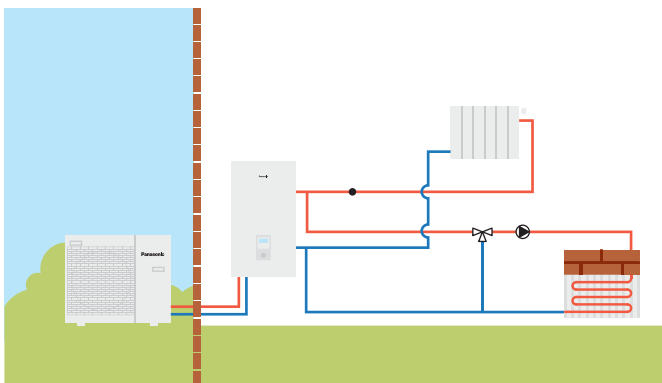

**Aquarea J and H Generation:**  
2 zones with external kit, buffer tank and swimming pool

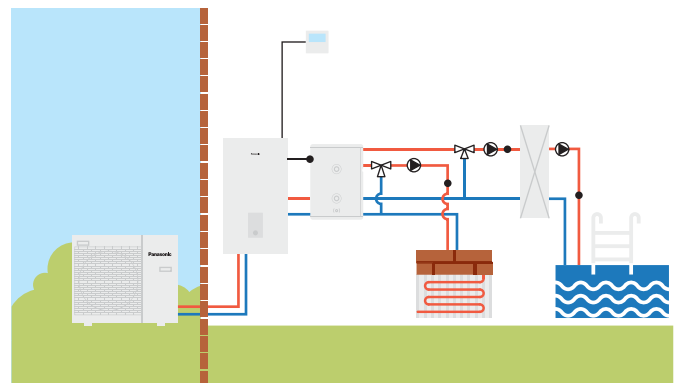

**Aquarea All in One J and H Generation:**  
2 zones with external kit, without buffer tank

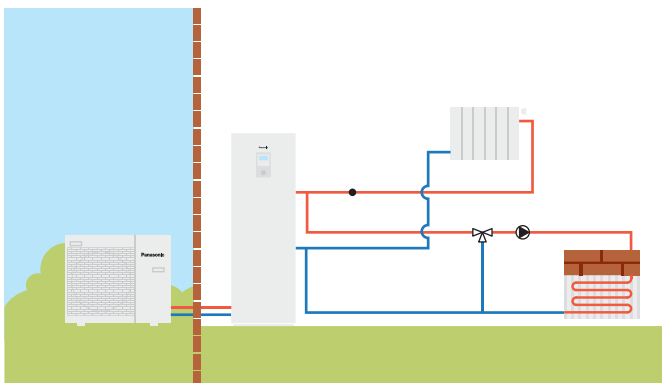

**Aquarea All in One 2 zones J and H Generation:**  
2 zones built-in, without buffer tank

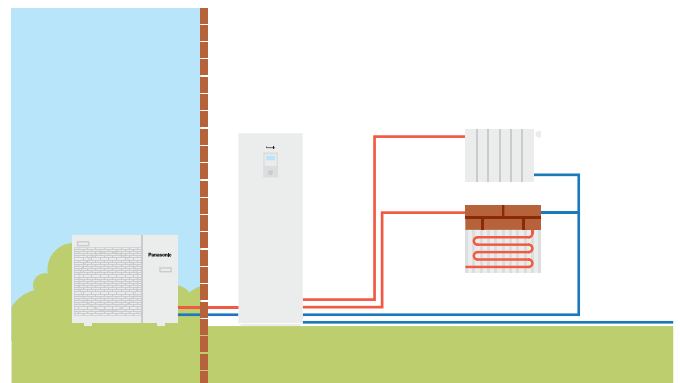



## Panasonic domestic air to air heat pump

Panasonic has developed a range of products designed for you, better than ever before. Above all, it is also a range for air conditioning professionals, such as yourself, thanks to its broad range of products which are capable of conditioning rooms of all sizes – always with optimal efficiency and incomparable ease of installation.

## New HZ Flagship: with nanoe™ X technology.

The new Flagship features an outstanding efficiency A+++ and higher heating capacity, even at very low outdoor temperatures. To improve the quality of the indoor air, the new unit includes the new nanoe X Generator Mark 2.



## New CZ super-compact unit.

The new CZ super-compact wall-mounted unit measure a mere 779 mm, ideal for installations in narrow spaces or above the door. The updated, elegant design is suitable for all types of interiors.

## nanoe™ X: Bringing nature's balance indoors.

Panasonic's nanoe™ X technology brings nature's detergent – hydroxyl radicals – indoors to help create an ideal environment.



## Built in Wi-Fi for Flagship and Etherea.

Flagship and Etherea are ready to connect to internet to be controlled by Panasonic Comfort Cloud, with completely new user interface and controlling all domestic functions.

## Voice Control.

Control without boundaries and get hands-free help to fully access the features of your air conditioners. Maximising your cooling comfort is now a breeze with our Network-Enabled Air Conditioners with Panasonic Comfort Cloud and Voice Control.



# Bringing nature's balance indoors

nanoe™ X, technology with the benefits of hydroxyl radicals.



Hydroxyl radicals contained in water

Hydroxyl radicals inhibit the growth of pollutants such as bacteria, viruses, moulds, and odours, breaking them down and neutralising the unpleasant effects. This naturally occurring process has major benefits to improve indoor environments. By creating hydroxyl radicals contained in tiny water particles, nanoe™ X technology significantly boosts their effectiveness, increasing hydroxyl radicals lifetime from less than a second in nature, to more than 600 seconds – 10 minutes so that nanoe™ X can spread over long distances.

## Panasonic's nanoe™ X technology takes this a step further and brings nature's detergent – hydroxyl radicals – indoors to help create an ideal environment

Thanks to the nanoe™ X properties, several types of pollutants can be deactivated such as bacteria, viruses, mould, allergens, pollen and certain hazardous substances.



nanoe™ X reliably reaches pollutants.

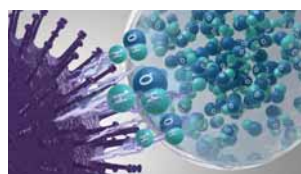

Hydroxyl radicals denature pollutants' proteins.



Pollutants activity is inhibited.

## What is unique about nanoe™ X?

Thanks to this advanced nano technology, even tightly woven fabrics can be treated using this solution, meaning that curtains, blinds, carpets and furniture can all benefit from this technology to inhibit hazardous substances – including on hard surfaces and, of course, the air that we breathe.

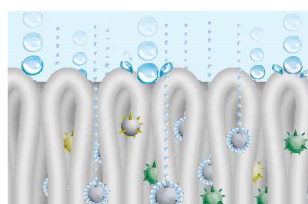

Microscopic scale. At one billionth of a metre, nanoe™ X is much smaller than steam and can deeply penetrate cloth fabrics to deodorise.



nanoe™ X can reach every corner of a space and its surfaces. Contained in tiny water particles, it has a long lifespan and is able to spread over long distances.



High performance. nanoe X Generator Mark 2 produces 9,6 trillion hydroxyl radicals per second. Greater amounts of hydroxyl radicals contained in nanoe™ X lead to outstanding effects in the inhibition of pollutants.



No maintenance. nanoe™ X a not based in filter maintenance-free solution made with titanium.

\* The image shows nanoe X Generator Mark 2.





Hydroxyl radical technology neutralises pollutants, viruses, and bacteria to clean and deodorise fabrics, hard surfaces and, of course, the air that we breathe.

**7 effects of nanoe™ X – technology with the benefits of hydroxyl radicals**

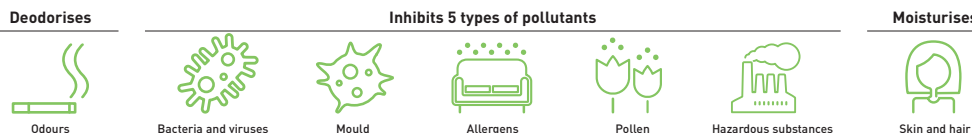

**nanoe™ X, internationally-validated technology**

The effectiveness of nanoe™ X technology has been tested by 3rd party laboratories in Germany, Denmark, Malaysia and Japan.

**99,9 %\***  
**OF CERTAIN BACTERIA INHIBITED**

	Tested contents	Result	Capacity	Time	Testing organisation	Report No.
Airborne	<b>Virus</b> Bacteriophage ΦX174	99,7 % inhibited	Approx. 25 m <sup>3</sup>	6 h	Kitasato Research Center for Environmental Science	24_0300_1
	<b>Bacteria</b> Staphylococcus aureus	99,9 % inhibited	Approx. 25 m <sup>3</sup>	4 h	Kitasato Research Center for Environmental Science	2016_0279
	Feline Coronavirus	99,3 % inhibited	45 L	2 h	Yamaguchi University Faculty of Agriculture	
Adhesive	<b>Virus</b> Xenotropic murine leukemia virus	99,999 % inhibited	45 L	6 h	Charles River Biopharmaceutical Services GmbH	
	Influenza (H1N1 subtype)	99,9 % inhibited	1 m <sup>3</sup>	2 h	Kitasato Research Center for Environmental Science	21_0084_1
	<b>Bacteria</b> Staphylococcus aureus	99,9 % inhibited	20 m <sup>3</sup>	8 h	Danish Technological Institute	868988
	<b>Pollen</b> Ambrosia pollen	99,4 % inhibited	20 m <sup>3</sup>	8 h	Danish Technological Institute	868988
	Cedar	97 % inhibited	Approx. 23 m <sup>3</sup>	8 h	Panasonic Product Analysis Center	4AA33-151001-F01
<b>Odours</b> Cigarette smoke odour	Odour intensity reduced by 2,4 levels	Approx. 23 m <sup>3</sup>	0,2 h	Panasonic Product Analysis Center	4AA33-160615-N04	



More about tests:  
<https://www.panasonic.com/global/consumer/clean.html>

\* Reduction of 99,9% of Staphylococcus aureus after 8 hours of exposure. Testing organisation: Danish Technological Institute. Report no. 868988.

**First nanoe™ device was developed by Panasonic in 2003**

After annual R&D investments, the technology has been improved with launch of nanoe™ X.

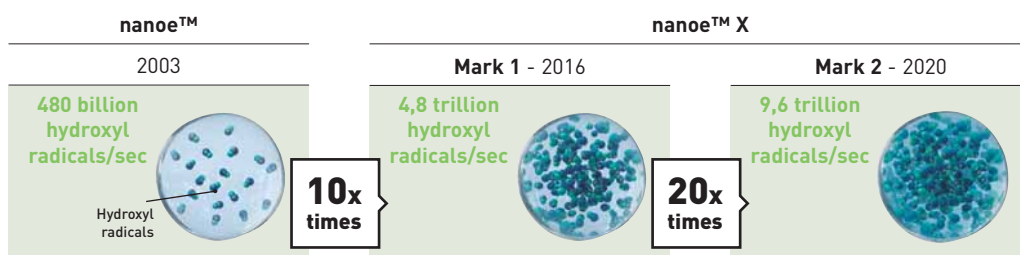

**nanoe X Generator Mark 1 can reduce cigarette smoke odour intensity by 2,4 levels in 12 minutes**

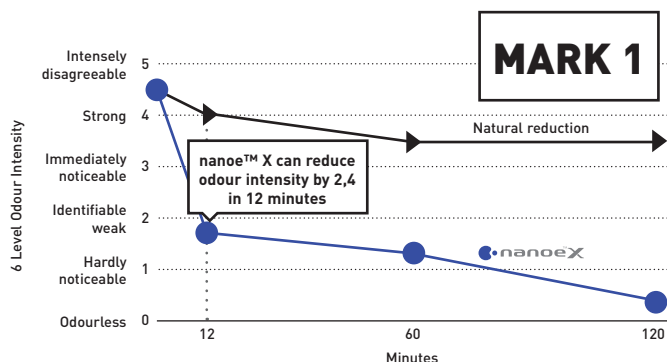

**Deodorisation effect for adhering odour (cigarette smoke).**  
**Deodorisation test.**  
Testing organisation: Panasonic Product Analysis Center. Testing method: Verified using the six-level odour intensity scale method in an approximately 23 m<sup>3</sup> sized test room. Deodorisation method: nanoe™ released. Test substance: Surface-attached cigarette smoke odour. Test result: Odour intensity reduced by 2,4 levels in 12 minutes. (4AA33-160615-N04).

**nanoe X Generator Mark 2 can reduce the aged-related body odour in half of the time**

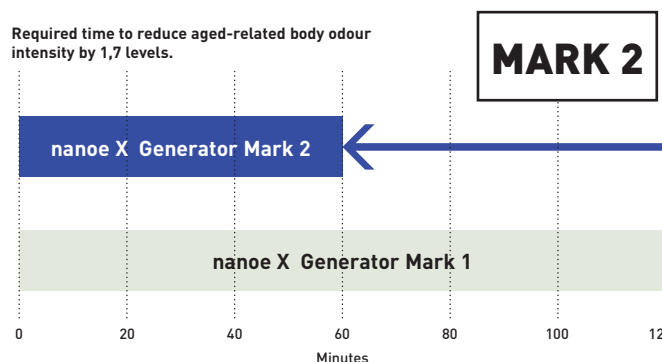

**Deodorisation test.**  
Testing organization: Panasonic Product Analysis Center. Testing method: Verified using the six-level odour intensity scale method in an approximately 23 m<sup>3</sup> sized test room. Deodorisation method: nanoe™ released. Test substance: Surface-attached aged related body odour. Test result: Odour intensity by 1.7 levels reduced in 1 hour (Y18HM059).

# Panasonic Comfort Cloud App. Convenient centralised control



## Advanced smartphone control for domestic range.

Control air to air heat pump operation with Panasonic Comfort Cloud plus additional functions only available through the Cloud from wherever and whenever. One user can manage up to 200 units and also set up different user rights. Also, energy monitoring is possible allowing opportunity to learn how to reduce the operating cost even more.

### 1 Smart Control

In control of cooling comfort anytime, anywhere.

#### Connect & control operation.

- 20 units per location and up to 10 different locations
- Transform multiple remote controls into one device

#### Manage multiple units at once.

- Turn on all AC units at the same time or by group settings
- Set weekly timers for multiple units to cater to your daily routines

### 2 Smart Comfort

Easily manage your comfort and air quality.

#### Adjust set temperature.

Set temperature by monitoring real time indoor and outdoor temperatures.

#### Pre-heat or cool.

Control your house or office comfort before you arrive!

#### nanoe™ X <sup>1)</sup>.

Activate nanoe™ X, the advanced technology to deodorise and create healthier environment.

### 3 Smart Efficiency

More comfort with less wasted energy.

#### Energy usage analysis <sup>2)</sup>.

Monitor energy consumption based on different temperature settings.

#### Energy usage comparison (day/week/month/year).

Compare energy usage history of AC units for better budget planning.

### 4 Smart Assist

Be informed of breakdowns.

#### Error codes notification and identification <sup>3)</sup>.

Launch the App to check error codes for effortless troubleshooting. Help technicians to easily identify the issues.

#### User's control right.

Register multiple users. Set administrator rights and assign users access.

1) nanoe™ X is available in certain series. 2) Estimated energy consumption data accuracy depends on power supply quantity. 3) Contact trained technicians to perform any repairing/service.

Easily control and access all features of remote control anytime, anywhere.

### New possibilities, new applications

**Families:** Different users can be set up, such as each child can manage their own room. In second homes, rooms can be remotely pre-cooled or pre-warmed, or turned off if needed.

**Multi tenant owner:** The ability to manage up to 200 units with just one smartphone. It allows for quick and efficient maintenance through remote error codes and the knowledge of consumption.

**Small and medium sized offices:** Owner can control different rooms of the office easily and give unit by unit access to their staff. Also provides information to know where energy might be wasted for heating and cooling and promoting best comfort practices.

### Smart control at your fingertips

With Panasonic Comfort Cloud, the user can manage all functions of the heat pump such as nanoe™ X, air flow direction, speed, temperature setting, mode, plus more.

### Scalability and users management

Easy to include additional units and locations, as well as the ability to include several users with different access rights. This creates more possibilities to manage the family home, a second house and also provides opportunities for small/medium sized offices or multi-tenant properties.

### Energy monitor and statistics

Knowing the energy each unit uses when operating is key to see opportunities to reduce the energy bill. Panasonic Comfort Cloud stores the energy consumption\* of each unit, which can then be shown in easy and powerful statistics graphs. This function is available from WKE, VKE, TKE and UKE generation. With the weekly timer the operation can be adjusted to optimize the usage of the energy.

\*Estimated energy consumption data accuracy depends on power supply quality.

### Connection Diagram to Panasonic Comfort Cloud

Indoor Unit

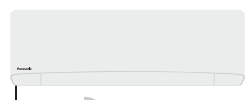

Network

Built-in Wi-Fi in certain models or with optional adaptor CZ-TACG1 connected to port CN-CNT.

Other hardware requirements (purchase and subscribe separately).



Panasonic Cloud Server is designed, operated and managed by Panasonic.

Download free App



Panasonic Comfort Cloud

Compatibility: Most Panasonic Domestic range are compatible with CZ-TACG1 Wi-Fi accessory: CS-VZ\*\*SKE, CS-HZ\*\*WKE, CS-LZ\*\*TKE, CS-NZ\*\*VKE, CS-CZ\*\*WKE, CS-Z\*\*UFEAW-1, CS-Z\*\*TKEA, CS-Z\*\*UB4EAW, CS-Z\*\*UD3EAW, CS-HZ\*\*UKE, CS-CZ\*\*TKE, CS-NZ\*\*TKE, CS-QZ\*\*SKE, CS-E\*\*PKEA, CS-E\*\*PB4EA, CS-E\*\*PD3EA.

Remark: indoor temperature display and some special functions are not available through the App for all models. Languages: Available in 19 European languages: Bulgarian, Croatian, Czech, Danish, Deutsch, English, Estonian, Finnish, French, Greek, Hungarian, Italian, Norwegian, Polish, Portuguese, Slovenian, Spanish, Swedish and Turkish.

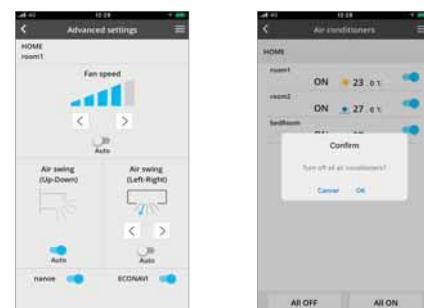
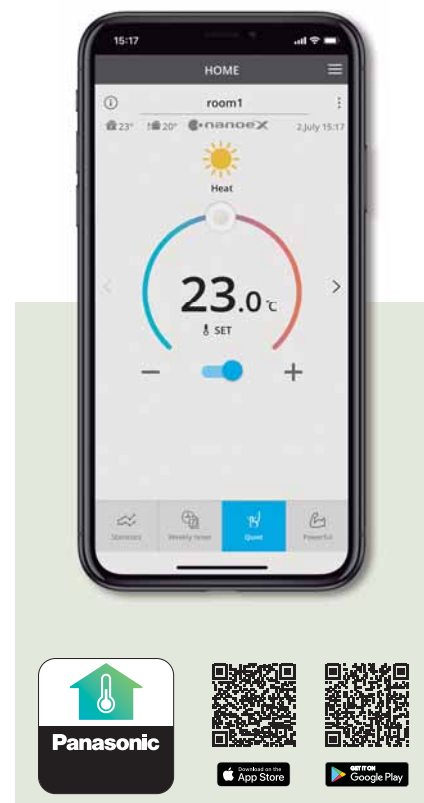

# New Voice Control. Words do more than actions

Operate the air with your voice.  
Enjoy the convenience of accessing these four basic operations with just your voice.



**1 Turn on/off air conditioner**  
**Convenient control for blissful rest.**  
Turn on/off AC with ease when preparing a comfortable space for your little ones.

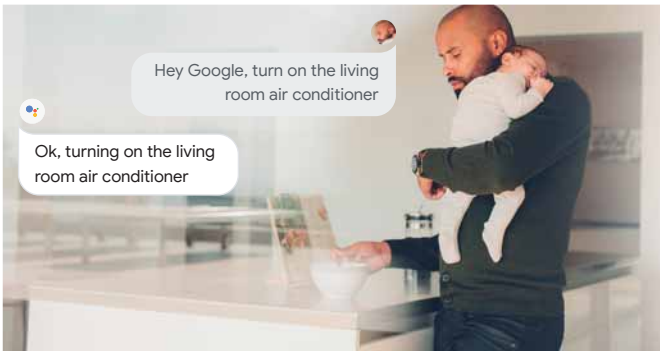

**3 Adjust temperature**  
**Easy control for uninterrupted quality time.**  
Adjust AC temperature to your comfort with a simple voice command.



**2 Change mode**  
**Extra help when you have a hectic day.**  
Conveniently change your AC operation mode to cool / heat / auto when your hands are full.



**4 Check current status**  
**Hands-free comfort for the whole family.**  
Easy access for the elderly to check current AC operation status and adjust AC settings.



Control without boundaries and get hands-free help to fully access the features of your air conditioners. Maximising your cooling comfort is now a breeze with our Network-Enabled air conditioners with Panasonic Comfort Cloud and Voice Control.



### Get multiple things done with your voice

Simplify your day with your personalised routine by grouping individual actions.

### Schedule your routine with your voice.

With the routine function, you can customise voice commands and control multiple voice-controlled devices including our network-enabled air conditioners to help you with your personalised routine.

#### Example of morning routine.

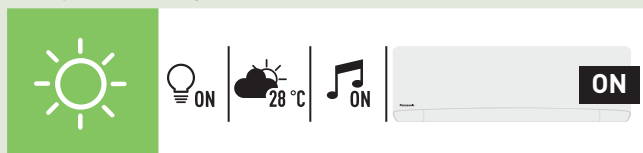

Find out more: [Amazon] <https://www.techhive.com/article/3327501/how-to-use-alexa-routines.html>

#### Example of night routine.

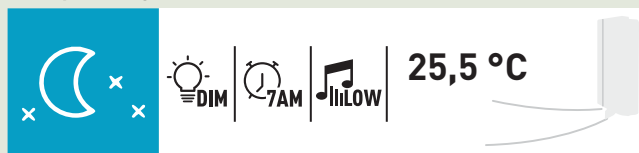

### Voice Control with Network-Enabled air conditioners

Functions	When you are home		When away from home
	Remote Control	Voice Control	Comfort Cloud App
Smart control	Power ON/OFF	✓	✓
	Control multiple AC units in 1 location	—	✓
	Control multiple units in multiple locations	—	✓
	Set up and manage routines	—	✓
Smart comfort	Cooling mode	✓	✓
	Heating mode	✓	✓
	Auto mode	✓	✓
	nanoe™ X mode	✓	—
	Summer House mode	✓	—
	Pre-cool	—	✓
	Change temperature	✓	✓
Smart efficiency	Analyse energy usage patterns	—	✓
	Compare historical usage	—	✓
Smart assist	Receive error notifications	—	✓
	Assign multiple users	—	✓
	Check power ON/OFF	✓	✓
	Check current mode	✓	✓
	Check temperature settings	✓	✓
	Check room temperature	✓	✓

### How to setup

To sync with your Voice Assistant, first the AC unit has to be registered in Panasonic Comfort Cloud.



#### How to sync Comfort Cloud with a Google Nest device.

1. Open the Google Home App.
2. Tap "Account".
3. Choose "Set up or add".
4. Choose "Set up device".
5. Choose "Works with Google; Have something already set up?"
6. Search for "Comfort Cloud".
7. Insert your "Comfort Cloud" username and password.



#### How to sync Comfort Cloud with the Amazon Alexa.

1. Open the Amazon Alexa App.
2. Tap "Devices".
3. Choose "Your Smart Home Skills".
4. Choose "Enable Smart Home Skills".
5. Search for "Comfort Cloud".
6. Insert your "Comfort Cloud" username and password.

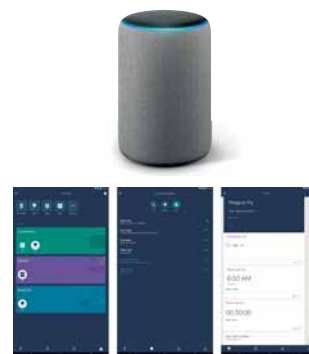

### Compatible device and browsers as of June 2020

1. Android™ 4.4 KitKat®\* or above
2. iOS 9.0 or above

#### Please note:

- This is not a definitive list of all compatible devices, other similar devices which use supported Operating Systems should also work either via dedicated Apps. Please note that user experience may vary slightly depending on hardware and software combination
- Google, Android, Google Play and Google Nest Mini are trademarks of Google LLC.
- Google Assistant is not available in certain languages and countries.
- Amazon, Alexa and all related logos are trademarks of Amazon.com, Inc. or its affiliates
- Availability of Voice Assistant services varies depending on country and language
- More information about set up procedures: <https://aircon.panasonic.com/connectivity/application.html>
- Google Assistant and Alexa are compatible with the models shown on page 84, 88.
- \* Android™ needs to be 5.0 Lollipop or above from September 2020 onward.



## New, super-compact units, redesigned for simple installation and maintenance



CZ's chassis have been carefully re-designed for simple, stress-free installation and ongoing maintenance.

**1 Simple installation**

Thanks to advanced improvements, installation time has been dramatically decreased. The new models have been designed to provide more stability and strength for neat installation, with newly built-in support and convenient access to the drain hose, cabling inserts and larger space for secure installation.

**2 Easy maintenance**

Meticulously designed for both installer and user benefit, the unit features an easy to remove front grille for convenient access to the interior. The inner workings of the unit have also been redesigned to make maintenance quicker and easier. Electronics and wiring components are now on just one side of the unit to simplify maintenance.



**1. Stronger installation plate.**

The new models feature a stronger, solid installation plate that provides more stability and strength. For uneven surfaces, there are 2 additional screws to ensure a neat and secure installation.

Installation plate: Strong and solid.



Screw holder for uneven surface (screws not provided).



**2. One-piece front grille.**

The new model comes with a one-piece front grille design to make servicing easier. First, open the intake grille and remove the screws. Next, slide the three slider locks and remove the front grille.

One-piece front grille: Easy removal.



Slider locks: Easy to unlock / lock.

**3. Built-in support holder.**

The new model features a built-in support holder, making installation easier and providing convenience and workspace improvements.

Convenient installation and serviceability.

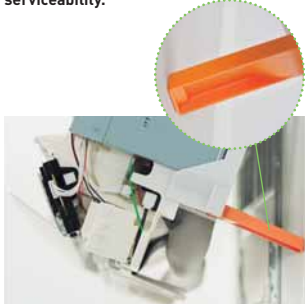

**4. Easy access to drain hose & piping connection.**

With larger piping space, pipes and insulations are securely and neatly hidden. With the new visible piping storage, pipes can easily be inspected for leaks without lifting the unit.

Piping storage: 15% larger.



Bigger working space.

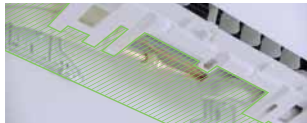

**5. Easy wire insertion & tightening.**

The new models have combined 2 wire inserts into 1, ensuring front visibility and convenience while inserting wires from the back.

Single tunnel: easy wire insert.



Bigger working space for wiring connection.



**6. Easy removal of PCB.**

PCB removal is achieved in just 4 easy steps. Simply remove the control board cover, disconnect all connectors from the indicator, disconnect all connectors and pull out the main PCB.

Simple steps for PCB removal.

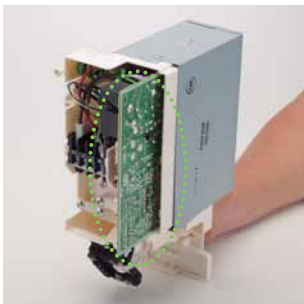

**7. Easy / hidden installation of the Wi-Fi adapter.**

The latest model features a dedicated space for a network adapter. Easy to plug in, the guided wire slots allow for clear, easy installation and can be neatly tucked away - simple and out of sight!

\* Only for models without built-in network adapter.



**8. Cross flow fan removal.**

The new models are carefully designed to make removal of cross flow fans easier compared to the previous models, saving valuable time.

Bigger diameter Ø100.



## A complete selection for Nordic households



Page	Indoor units	2,5 kW	3,5 kW	5,0 kW
P. 82	Wall-mounted Heatcharge VZ Inverter+ • R32 refrigerant 	CS-VZ9SKE CU-VZ9SKE	CS-VZ12SKE CU-VZ12SKE	
P. 84	<b>NEW</b> Wall-mounted HZ Flagship Inverter+ • R32 refrigerant 	CS-HZ25WKE CU-HZ25WKE	CS-HZ35WKE CU-HZ35WKE	
P. 86	Wall-mounted LZ Retro Fit Inverter+ • R32 refrigerant 	CS-LZ25TKE CU-LZ25TKE	CS-LZ35TKE CU-LZ35TKE	
P. 88	Wall-mounted NZ Etherea Inverter+ • R32 refrigerant 	CS-NZ25VKE CU-NZ25VKE	CS-NZ35VKE CU-NZ35VKE	CS-NZ50VKE CU-NZ50VKE
P. 90	<b>NEW</b> Wall-mounted CZ Inverter • R32 refrigerant 	CS-CZ25WKE CU-CZ25WKE	CS-CZ35WKE CU-CZ35WKE	
P. 92	Floor Console Inverter+ • R32 refrigerant 	CS-Z25UFEAW-1 CU-Z25UFEA-1	CS-Z35UFEAW-1 CU-Z35UFEA-1	



### Choose the correct model

In order to maximize comfort and savings, it is important that you choose the correct model of your heat pump. A heat pump with too little or too much power will not be able to provide the desired savings. A heat pump with an insufficient air flow rate will not manage to distribute heat in a larger building. A heat pump without remote control reduces comfort and control in the summer house.

Please contact an installer/dealer for assistance in choosing the correct model or use the guide below.

VZ Heatcharge	HZ Flagship	LZ Retro Fit 249	NZ Etherea	CZ Basic Inverter	Floor Console
					
The top model for cold areas	The best seller for larger houses	The perfect replacement model	The design model	The budget model	The floor model
<b>Tested by 3rd party laboratory down to -35 °C</b>					
✓ SP <sup>1)</sup>		✓ DTI <sup>2)</sup>			✓ DTI <sup>2)</sup>
<b>Lowest sound level (18 dB(A))</b>					
✓	✓	✓			
<b>Air purification</b>					
✓ nanoe™	✓ nanoe™ X Mark 2	✓	✓		✓ nanoe™ X Mark 1
<b>Maximum capacity</b>					
9,20 kW	7.83 kW	7,65 kW	8,20 kW	6,70 kW	6,20 kW
<b>Home 190-230 sq. m</b>					
✓					
<b>Home 150-190 sq. m</b>					
✓	✓	✓			
<b>Home 100-150 sq. m</b>					
	✓	✓	✓		✓
<b>Home 50-100 sq. m</b>					
		✓	✓	✓	✓
<b>Summer House</b>					
	✓		✓	✓	✓
<b>Garage / Shed / Permit-free building</b>					
			✓	✓	✓
<b>SCOP</b>					
6,20 A+++	5.20 <sup>3)</sup> A+++	5,17 <sup>3)</sup> A+++ <sup>4)</sup>	4,70 A++	4.30 A+	4,79 <sup>3)</sup> A++
<b>No cold air dumping when defrosting</b>					
✓					
<b>Highest energy class (A+++)</b>					
✓	✓	✓			
<b>R32 Gas</b>					
✓	✓	✓	✓	✓	✓
<b>Compatible with Internet control</b>					
✓	Included	✓	Included	✓	✓
<b>Summer cottage function</b>					
✓	✓	✓	✓	✓	✓
<b>Econavi</b>					
✓					
<b>Replacement model</b>					
		✓	✓		

1) -35°C tested by SP, in accordance with EN 14511:2013 and SP Method 1721 (this temperature is not guaranteed by the factory). 2) -35°C tested by DTI, an independent test laboratory, in accordance with EN 14511:2013 (this temperature is not guaranteed by the factory). 3) SCOP tested by the independent testing laboratory, DTI, in accordance with EN 14825:2016. 4) A+++ has been calculated on the basis of the SCOP test performed by the Danish Technological Institute. The test report from the Danish Technological Institute can be found at: lz25test.panasonic.se

# Heatcharge. Energy Charge System

heatcharge

Energy class A+++ and offers maximum comfort and energy savings. This powerful air heat pump is designed for commercial and residential climate that places extremely high demands on the heating system.



## 1 Powerful, reliable heating even at low ambient winter temperatures

When the air conditioner is operating, the compressor, which is the power source of the unit, generates heat. Until now, this heat was released into the atmosphere. Panasonic has utilised this waste heat!

### Constant heating.

Using stored heat provides stable heating with less drop in temperature.

Even when heating operation stops during defrost operation, stored heat continues to constantly warm the room. This eliminates the previous discomfort due to the temperature dropping when heating temporarily stops to ensure stable air conditioner heating.



## 2 Panasonic's full line-up of A+++ heat pumps

In response to the Kyoto Protocol, the European Union set some challenging targets for the reduction in greenhouse-gas emissions. By the year 2020, across the member states, the EU wants to have achieved the following objectives:

- A 20 % cut in greenhouse gas emissions (from 1990 base levels)
- The share of renewables in the energy mix to increase by 20 %
- An overall reduction of 20 % in energy consumption

**Conventional.** The room gradually becomes cold.  
Defrost operation: About 11 to 15 min. Fall in room temperature: About 5 to 6 °C.

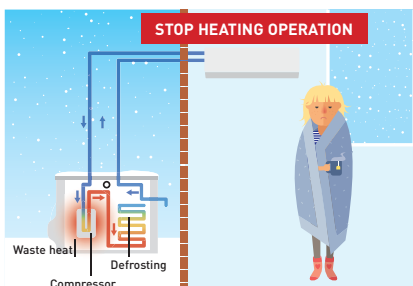

**Heatcharge.** The room is thoroughly warmed.  
Defrost operation: About 5 to 6 min. Fall in room temperature: About 1 to 2 °C.

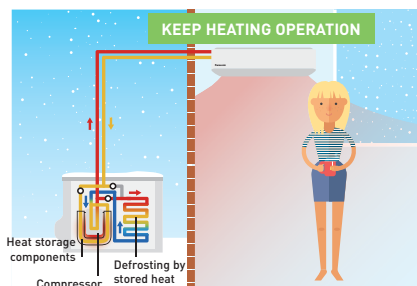

\* Defrost operation time and how low room temperature falls differ depending on the environment in which the unit is being used (how insulated and airtight the room is), operation conditions, and temperature conditions.

\* Output air temperature falls during defrost operation. How low room temperature falls differs depending on the environment in which the unit is being used (how insulated and airtight the room is), operation conditions, and temperature conditions.

\* In environments where a lot of frost accumulates, heating may stop during defrost operation.

## 3 Comfort and efficiency

- nanoe™ with nano-technology nano-sized electrostatic atomised water particles clean the air in the room
- Higher efficiency and comfort with Econavi sunlight detection and human activity detection
- Powerful air flow to quickly reach the desired temperature



**CZ-TACG1**  
Optional Wi-Fi  
Panasonic Comfort  
Cloud for internet  
control.

## Wall-mounted Heatcharge VZ Inverter+ • R32 refrigerant

Maximum capacity			7,80 kW	9,20 kW
Indoor unit			CS-VZ9SKE	CS-VZ12SKE
Outdoor unit			CU-VZ9SKE	CU-VZ12SKE
Heating capacity	Nominal (Min - Max)	kW	3,60 (0,60 - 7,80)	4,20 (0,60 - 9,20)
COP <sup>1)</sup>		W/W	5,63	5,04
Heating capacity at -7 °C		kW	5,00	5,60
COP at -7 °C <sup>1)</sup>		W/W	2,07	2,00
Heating capacity at -15 °C		kW	4,80	5,22
COP at -15 °C <sup>1)</sup>		W/W	1,94	1,90
Heating capacity at -25 °C (tested by SP)		kW	3,72	3,67
COP at -25 °C (tested by SP)		W/W	1,63	1,50
Heating capacity at -35 °C (tested by SP)		kW	2,51	2,44
COP at -35 °C (tested by SP)		W/W	1,32	1,15
<b>SCOP <sup>2)</sup></b>		<b>W/W</b>	<b>6,20 A+++</b>	<b>5,90 A+++</b>
Pdesign at -10 °C		kW	3,60	4,20
Input power heating	Nominal (Min - Max)	kW	0,64 (0,14 - 2,72)	0,83 (0,14 - 3,16)
Annual energy consumption <sup>3)</sup>		kWh/a	812	995
Cooling capacity	Nominal (Min - Max)	kW	2,50 (0,60 - 3,00)	3,50 (0,60 - 4,00)
<b>SEER <sup>1)</sup></b>			<b>10,50 A+++</b>	<b>10,00 A+++</b>
Pdesign (cooling)		kW	2,50	3,50
Input power cooling	Nominal (Min - Max)	kW	0,43 (0,14 - 0,61)	0,80 (0,14 - 0,98)
Annual energy consumption <sup>3)</sup>		kWh/a	83	122
<b>Indoor unit</b>				
Power source		V	230	230
Recommended fuse		A	16	16
Connection indoor / outdoor		mm <sup>2</sup>	4 x 1,5	4 x 1,5
Air volume	Heat / Cool (Hi)	m <sup>3</sup> /min	15,5 / 12,5	15,9 / 12,9
Sound pressure <sup>4)</sup>	Heat (Hi / Lo / Q-Lo)	dB(A)	44 / 26 / 18	45 / 29 / 18
	Cool (Hi / Lo / Q-Lo)	dB(A)	44 / 27 / 18	45 / 33 / 18
Dimension	H x W x D	mm	295 x 798 x 375	295 x 798 x 375
Net weight		kg	14,5	14,5
<b>Outdoor unit</b>				
Air volume	Heat / Cool (Hi)	m <sup>3</sup> /min	33,1 / 33,1	33,9 / 35,4
Sound pressure <sup>4)</sup>	Heat / Cool (Hi)	dB(A)	49 / 49	50 / 50
Dimension <sup>5)</sup>	H x W x D	mm	630 x 799 x 299	630 x 799 x 299
Net weight		kg	39,5	39,5
Piping connections	Liquid pipe	Inch (mm)	1/4 (6,35)	1/4 (6,35)
	Gas pipe	Inch (mm)	3/8 (9,52)	3/8 (9,52)
Pipe length range		m	3 - 15	3 - 15
Elevation difference (in/out) <sup>6)</sup>		m	12	12
Pipe length for additional gas		m	7,5	7,5
Additional gas amount		g/m	20	20
Refrigerant (R32) / CO <sub>2</sub> Eq.		kg / T	1,05 / 0,70875	1,10 / 0,7425
Operating range	Heat Min ~ Max	°C	-30 ~ +24	-30 ~ +24
	Cool Min ~ Max	°C	-10 ~ +43	-10 ~ +43
Lowest outdoor temperature tested by 3rd party laboratory <sup>7)</sup>		°C	-35	-35

### Accessories

<b>CZ-TACG1</b>	Panasonic Comfort Cloud for internet control
<b>CZ-CAPRA1</b>	RAC interface adapter for integration into P-Link

### Accessories

<b>PAW-SMCONTROL</b>	Control by SMS (need additional SIM card)
----------------------	---

1) COP calculation is based in accordance to EN14511. 2) Energy Label Scale from A+++ to D. 3) The annual energy consumption is calculated in accordance to EU/626/2011. 4) The sound pressure of the indoor unit shows the value measured of a position of 1 m in front of the main body and 0,8 m below the unit. For outdoor unit 1 m in front and 1 m in rear side of main body. The sound pressure is measured in accordance with JIS C 9612. Q-Lo: Quiet mode. Lo: The lowest set fan speed. 5) Add 70 mm for piping port. 6) When installing the outdoor unit at a higher position than the indoor unit. 7) Tested by 3rd party laboratory, SP, according to EN14511:2013 and SP Method 1721, this temperature is not guaranteed by Factory.

**P** CERTIFIED **SP** **SE** **RE** The product is P-labelled. The P-labelling means that the product fulfils legal and regulatory requirements, but also in most cases, other, higher requirements that meet market demands. P-labelling means that the product is type approved and that the manufacturer's quality controls are monitored by SP. Certificated No.: SC0450-16. Certificated No.: SC0451-16.



SEER and SCOP: For CS-VZ9SKE. -35°C HEATING MODE: Heating performance tested at -35°C by SP, European 3rd party laboratory. INTERNET CONTROL: Optional.

## New Flagship

FLAGSHIP

Thanks to its exceptional performance and reliability, it is one of the best-selling heat pumps in the Nordic region. Its efficiency helps to quickly reach and maintain a comfortable indoor climate. Energy efficiency class A+++.



**1 New nanoe™ X technology**  Doubled OH radicals, nanoe X Generator Mark 2, realise faster suppression of pollutants and odours.

**2 New improved heating power** Heating capacity has further Improved. Stable and reliable heating is realised even in the extreme low temperature of midwinter.

**3 High Energy efficiency class A+++** Panasonic has combined its finest technology in a heat pump to deliver comfort and high efficiency. Thanks to Panasonic's original Inverter compressor, the heart of a heat pump, high levels of energy efficiency are achieved. As a results, operating costs are substantially reduced.

**4 Built-in Wi-Fi and compatible with Voice Assistant** The unit is ready to connect to the internet and to be controlled by smartphone with Panasonic Comfort Cloud App. Control, monitor, and schedule with easy interface.

By connecting Panasonic Comfort Cloud the unit can be managed by Google Assistant and Amazon Alexa\*.

\* Amazon, Alexa and all related logos are trademarks of Amazon.com, Inc. or its affiliates Google, Android, Google Play and Google Home are trademarks of Google LLC.



### New indoor unit design & controller

#### Indoor unit.

The badge colour has been changed to light warm silver.

A stylish look that blends with any interior.

#### Controller.

Button layout has been changed for easier operation.





Built-in Wi-Fi  
Panasonic Comfort  
Cloud for internet  
control.

## New Wall-mounted HZ Flagship Inverter+ • R32 refrigerant

Maximum capacity			7,40 kW	7,83 kW
Indoor unit			CS-HZ25WKE	CS-HZ35WKE
Outdoor unit			CU-HZ25WKE	CU-HZ35WKE
Heating capacity	Nominal (Min - Max)	kW	3,20 (0,85 - 7,40)	4,20 (0,85 - 7,83)
COP <sup>1)</sup>		W/W	5,61	5,00
Heating capacity at -7 °C <sup>2)</sup>		kW	4,75	4,80
COP at -7 °C <sup>1)</sup>		W/W	2,53	2,53
Heating capacity at -15 °C <sup>2)</sup>		kW	4,60	4,70
COP at -15 °C <sup>1)</sup>		W/W	2,47	2,45
Heating capacity at -20 °C <sup>2)</sup>		kW	4,03	4,08
COP at -20 °C <sup>1)</sup>		W/W	2,33	2,29
Heating capacity at -25 °C <sup>2)</sup>		kW	3,43	3,53
COP at -25 °C <sup>1)</sup>		W/W	2,14	2,13
<b>SCOP<sup>3)</sup></b>			<b>5,20 A+++</b>	<b>5,10 A+++</b>
Pdesign at -10 °C		kW	3,00	4,00
Input power heating	Nominal (Min - Max)	kW	0,57 (0,17 - 2,10)	0,84 (0,17 - 2,19)
Annual energy consumption <sup>4)</sup>		kWh/a	808	1098
Cooling capacity	Nominal (Min - Max)	kW	2,50 (0,85 - 3,00)	3,50 (0,85 - 4,00)
<b>SEER<sup>3)</sup></b>			<b>7,80 A++</b>	<b>7,60 A++</b>
Pdesign (cooling)		kW	2,50	3,50
Input power cooling	Nominal (Min - Max)	kW	0,46 (0,17 - 0,67)	0,83 (0,17 - 0,99)
Annual energy consumption <sup>4)</sup>		kWh/a	112	161
<b>Indoor unit</b>				
Power source		V	230	230
Recommended fuse		A	16	16
Air volume	Heat / Cool	m <sup>3</sup> /min	15,6 / 14,0	15,6 / 14,0
Moisture removal volume		l/h	1,5	2,0
Sound pressure <sup>5)</sup>	Heat (Hi / Lo / Q-Lo)	dB(A)	45 / 24 / 18	45 / 25 / 18
	Cool (Hi / Lo / Q-Lo)	dB(A)	44 / 25 / 20	44 / 28 / 20
Dimension	H x W x D	mm	295 x 870 x 230	295 x 870 x 230
Net weight		kg	10	10
nanoe X Generator			Mark 2	Mark 2
<b>Outdoor unit</b>				
Air volume	Heat / Cool	m <sup>3</sup> /min	32,7 / 32,7	35,6 / 34,4
Sound pressure <sup>5)</sup>	Heat - Cool (Hi / Lo)	dB(A)	47 / 44 - 46 / 43	50 / 47 - 48 / 45
Dimension <sup>6)</sup>	H x W x D	mm	622 x 824 x 299	622 x 824 x 299
Net weight		kg	36	36
Piping connections	Liquid pipe	Inch (mm)	1/4 (6,35)	1/4 (6,35)
	Gas pipe	Inch (mm)	3/8 (9,52)	3/8 (9,52)
Pipe length range		m	3 - 20	3 - 20
Elevation difference (in/out) <sup>7)</sup>		m	10	10
Pipe length for additional gas		m	7,5	7,5
Additional gas amount		g/m	20	20
Refrigerant (R32) / CO <sub>2</sub> Eq.		kg / T	1,12 / 0,756	1,12 / 0,756
Operating range	Heat Min - Max	°C	-25 ~ +24	-25 ~ +24
	Cool Min - Max	°C	+16 ~ +43	+16 ~ +43

### Accessories

**CZ-CAPRA1** RAC interface adapter for integration into P-Link

### Accessories

**CZ-RD514C** Wired remote controller for Wall-mounted and Floor Console

1) COP calculation is based in accordance to EN14511. 2) Capacity of the heat pump is tested with powerful mode with deice mode included. 3) SCOP and SEER values are Panasonic Factory official result, Energy Label Scale from A+++ to D. 4) The annual energy consumption is calculated in accordance to EU/626/2011. 5) The sound pressure of the indoor unit shows the value measured of a position of 1 m in front of the main body and 0,8 m below the unit. For outdoor unit 1 m in front and 1 m in rear side of main body. The sound pressure is measured in accordance with JIS C 9612. Q-Lo: Quiet mode. Lo: The lowest set fan speed. 6) Add 70 mm for piping port. 7) When installing the outdoor unit at a higher position than the indoor unit.



SCOP and SEER: For CS-HZ25WKE. INTERNET CONTROL: Built-in Wi-Fi.

## Wall-mounted LZ Retro Fit

Due to its well-thought-out design, LZ is perfect as a replacement pump. Only 249 mm high.



### 1 The LZ series is perfect for replacing a 7–10 year old heat pump

The LZ models are efficient and reliable even at outdoor temperatures as low as  $-35^{\circ}\text{C}$ . Due to its well-thought-out design, LZ is perfect as a replacement pump.

### 2 Only 249 mm high

Only 249 mm high and fits perfectly above the front door for a discreet installation. Thanks to its thoughtful design, LZ is perfect as a replacement pump.



### 3 Perfect as a replacement pump

LZ's design and dimensions are adapted to facilitate the replacement of an older Panasonic model. For example, the height of the inner section is the same as the older CKP and DKE models. This means that the existing position, e.g. above the outer door, can be retained. This is often not possible as the height of modern inner sections has generally increased. It is not necessary to replace the brackets behind the heat pump either and the pipe size is identical. Replacing a 10 year old heat pump with a new one is often a good investment. Modern heat pumps have a higher energy efficiency which benefits both the environment and your wallet. You will also benefit from new practical functions such as maintenance heating, remote control, better air purification and a timer setting.





**CZ-TACG1**  
Optional Wi-Fi  
Panasonic Comfort  
Cloud for internet  
control.

## Wall-mounted LZ Retro Fit 249 Inverter+ • R32 refrigerant

Maximum capacity			6,55 kW	7,65 kW
Indoor unit			CS-LZ25TKE	CS-LZ35TKE
Outdoor unit			CU-LZ25TKE	CU-LZ35TKE
Heating capacity	Nominal (Min - Max)	kW	3,20 (0,85 - 6,55)	4,20 (0,85 - 7,65)
COP <sup>1)</sup>		W/W	5,12	4,72
Heating capacity at -7 °C <sup>2)</sup>		kW	4,00	4,60
COP at -7 °C <sup>1)</sup>		W/W	2,52	2,35
Heating capacity at -15 °C <sup>2)</sup>		kW	3,90	4,35
COP at -15 °C <sup>1)</sup>		W/W	2,27	2,25
Heating capacity at -20 °C <sup>2)</sup>		kW	3,30	3,70
COP at -20 °C <sup>1)</sup>		W/W	2,04	2,03
Heating capacity at -25 °C <sup>2)</sup>		kW	2,70	3,10
COP at -25 °C <sup>1)</sup>		W/W	1,83	1,83
<b>SCOP <sup>3)</sup></b>			<b>5,00 A++</b>	<b>4,90 A++</b>
SCOP tested by 3rd party laboratory DTI <sup>4)</sup>			5,17 <sup>4)</sup> A+++ <sup>5)</sup>	—
Pdesign at -10 °C		kW	3,00	3,80
Input power heating	Nominal (Min - Max)	kW	0,63 (0,17 - 1,77)	0,89 (0,17 - 2,30)
Annual energy consumption <sup>6)</sup>		kWh/a	840	1086
Cooling capacity	Nominal (Min - Max)	kW	2,50 (0,85 - 3,00)	3,50 (0,85 - 4,00)
<b>SEER <sup>3)</sup></b>			<b>7,60 A++</b>	<b>7,40 A++</b>
Pdesign (cooling)		kW	2,50	3,50
Input power cooling	Nominal (Min - Max)	kW	0,51 (0,17 - 0,70)	0,86 (0,17 - 1,08)
Annual energy consumption <sup>6)</sup>		kWh/a	115	166
<b>Indoor unit</b>				
Power source		V	230	230
Recommended fuse		A	10	10
Air volume	Heat / Cool	m <sup>3</sup> /min	12,5/9,3	13,0/10,5
Moisture removal volume		l/h	1,5	2,0
Sound pressure <sup>7)</sup>	Heat (Hi / Lo / Q-Lo)	dB(A)	45/29/18	46/30/19
	Cool (Hi / Lo / Q-Lo)	dB(A)	40/25/21	43/28/21
Dimension	H x W x D	mm	249 x 790 x 355	249 x 790 x 355
Net weight		kg	11	11
<b>Outdoor unit</b>				
Air volume	Heat / Cool	m <sup>3</sup> /min	34,0/33,1	35,6/34,4
Sound pressure <sup>7)</sup>	Heat / Cool (Hi)	dB(A)	44/43	47/45
Dimension <sup>8)</sup>	H x W x D	mm	622 x 824 x 299	622 x 824 x 299
Net weight		kg	38	38
Piping connections	Liquid pipe	Inch (mm)	1/4 (6,35)	1/4 (6,35)
	Gas pipe	Inch (mm)	3/8 (9,52)	3/8 (9,52)
Pipe length range		m	3 - 20	3 - 20
Elevation difference (in/out) <sup>9)</sup>		m	10	10
Pipe length for additional gas		m	7,5	7,5
Additional gas amount		g/m	20	20
Refrigerant (R32) / CO <sub>2</sub> Eq.		kg / T	1,10 / 0,743	1,10 / 0,743
Operating range	Heat Min - Max	°C	-20 ~ +24	-20 ~ +24
	Cool Min - Max	°C	-15 ~ +43	-15 ~ +43
Lowest outdoor temperature tested by 3rd party laboratory <sup>10)</sup>		°C	-35	—

### Accessories

<b>CZ-TACG1</b>	Panasonic Comfort Cloud for internet control
<b>CZ-CAPRA1</b>	RAC interface adapter for integration into P-Link

### Accessories

<b>PAW-SMSCONTROL</b>	Control by SMS (need additional SIM card)
<b>CZ-RD514C</b>	Wired remote controller for Wall-mounted and Floor Console

1) COP calculation is based in accordance to EN14511. 2) Capacity of the heat pump is tested with powerful mode with deice mode included. 3) Energy Label Scale from A+++ to D. 4) SCOP tested by the independent testing laboratory, DTI, in accordance with EN 14825:2016. 5) A+++ has been calculated on the basis of the SCOP test performed by the Danish Technological Institute. The test report from the Danish Technological Institute can be found at: lz25test.panasonic.se. 6) The annual energy consumption is calculated in accordance to EU/626/2011. 7) The sound pressure of the indoor unit shows the value measured of a position of 1 m in front of the main body and 0,8 m below the unit. For outdoor unit 1 m in front and 1 m in rear side of main body. The sound pressure is measured in accordance with JIS C 9612. Q-Lo: Quiet mode. Lo: The lowest set fan speed. 8) Add 70 mm for piping port. 9) When installing the outdoor unit at a higher position than the indoor unit. 10) Tested by 3rd party laboratory, DTI, according to EN14511:2013, this temperature is not guaranteed by Factory.



SCOP and SEER: For CS-LZ25TKE. SUPER QUIET: For CS-LZ25TKE. -35 °C HEATING MODE: For CS-LZ25TKE heating performance tested at the -35 °C by SP, European 3rd party laboratory. INTERNET CONTROL: Optional. \* SCOP tested by the independent testing laboratory, DTI, in accordance with EN 14825:2016 - A+++ has been calculated on the basis of the SCOP test performed by the Danish Technological Institute. The test report from the Danish Technological Institute can be found at: lz25test.panasonic.se.

# Etherea

—ETHEREA—

The models in the NZ series are powerful, highly efficient, and reliable year-round. The NZ models are efficient and reliable year-round, and are specially designed for the tough Nordic climate. Due to its clever design, the NZ is perfect as a replacement pump.



## 1 Built-in Wi-Fi and compatible with Voice Assistant

The unit is ready to connect to the internet and to be controlled by smartphone with Panasonic Comfort Cloud App. Control, monitor, and schedule with easy interface.

By connecting Panasonic Comfort Cloud the unit can be managed by Google Assistant and Amazon Alexa\*.

\* Amazon, Alexa and all related logos are trademarks of Amazon.com, Inc. or its affiliates. Google, Android, Google Play and Google Home are trademarks of Google LLC.



## 2 Summer House

Keep your summer house, garage, or permit-free auxiliary building frost-free without using a lot of energy.

## 3 New wireless control

Enjoy innovative design at your fingertips with the new stylish and sleek Backlit Sky Controller. Bigger screen and easier to use.



## 4 Etherea maximum savings, outstanding efficiency A++

Highest energy class. Original Panasonic Inverter technology and a high performance compressor provide top-class operating efficiency. This lets you enjoy lower electricity bills while contributing to environmental protection.

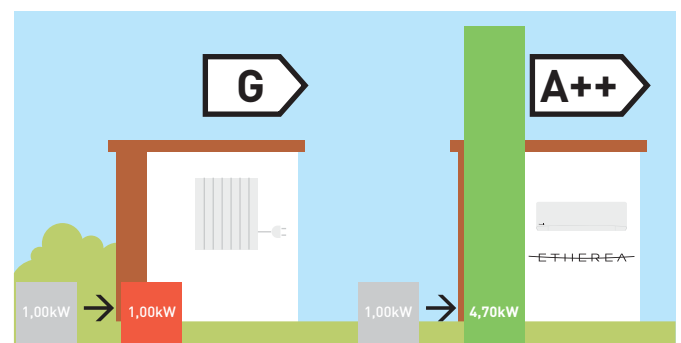

\* SCOP on heating mode for CS-NZ25VKE and CS-NZ50VKE compared with electrical heaters at +7°C.





Built-in Wi-Fi  
Panasonic Comfort  
Cloud for internet  
control.

## Wall-mounted NZ Etherea Inverter+ • R32 refrigerant

Maximum capacity			6,30 kW	7,30 kW	8,20 kW
Indoor unit			CS-NZ25VKE	CS-NZ35VKE	CS-NZ50VKE
Outdoor unit			CU-NZ25VKE	CU-NZ35VKE	CU-NZ50VKE
Heating capacity	Nominal (Min - Max)	kW	3,40 (0,85 - 6,30)	4,00 (0,85 - 7,30)	5,80 (0,98 - 8,20)
COP <sup>1)</sup>		W/W	4,86	4,44	4,23
Heating capacity at -7 °C <sup>2)</sup>		kW	4,00	4,60	5,20
COP at -7 °C <sup>1)</sup>		W/W	2,47	2,12	2,39
Heating capacity at -15 °C <sup>2)</sup>		kW	3,40	4,20	4,90
COP at -15 °C <sup>1)</sup>		W/W	2,19	2,11	2,34
Heating capacity at -20 °C <sup>2)</sup>		kW	2,80	3,60	4,15
COP at -20 °C <sup>1)</sup>		W/W	1,96	2,00	2,17
Heating capacity at -25 °C <sup>2)</sup>		kW	2,20	3,00	3,70
COP at -25 °C <sup>1)</sup>		W/W	1,65	1,84	1,99
<b>SCOP<sup>3)</sup></b>			<b>4,60 A++</b>	<b>4,70 A++</b>	<b>4,70 A++</b>
Pdesign at -10 °C		kW	2,80	3,60	4,40
Input power heating	Nominal (Min - Max)	kW	0,70 (0,17 - 1,73)	0,90 (0,17 - 2,32)	1,37 (0,22 - 2,42)
Annual energy consumption <sup>4)</sup>		kWh/a	852	1072	1311
Cooling capacity	Nominal (Min - Max)	kW	2,50 (0,85 - 3,00)	3,50 (0,85 - 4,00)	5,00 (0,98 - 6,00)
<b>SEER<sup>3)</sup></b>			<b>7,50 A++</b>	<b>7,40 A++</b>	<b>7,50 A++</b>
Pdesign (cooling)		kW	2,50	3,50	5,00
Input power cooling	Nominal (Min - Max)	kW	0,51 (0,17 - 0,70)	0,86 (0,17 - 1,10)	1,34 (0,25 - 1,85)
Annual energy consumption <sup>4)</sup>		kWh/a	117	166	233
<b>Indoor unit</b>					
Power source		V	230	230	230
Recommended fuse		A	10	10	13
Air volume	Heat / Cool	m <sup>3</sup> /min	12,3/10,9	12,4/11,3	20,8/19,6
Moisture removal volume		l/h	1,5	2,0	2,8
Sound pressure <sup>5)</sup>	Heat (Hi / Lo / Q-Lo)	dB(A)	42/27/19	44/30/19	44/37/30
	Cool (Hi / Lo / Q-Lo)	dB(A)	39/25/21	42/28/21	44/37/30
Dimension	H x W x D	mm	295 x 919 x 194	295 x 919 x 194	295 x 1120 x 236
Net weight		kg	9	10	12
<b>Outdoor unit</b>					
Air volume	Heat / Cool	m <sup>3</sup> /min	31,4/31,4	35,1/33,9	38,6/39,7
Sound pressure <sup>5)</sup>	Heat — Cool (Hi / Lo)	dB(A)	48/45 — 46/43	50/47 — 48/45	50/47 — 48/45
Dimension <sup>6)</sup>	H x W x D	mm	622 x 824 x 299	622 x 824 x 299	701 x 875 x 320
Net weight		kg	35	36	47
Piping connections	Liquid pipe	Inch (mm)	1/4 (6,35)	1/4 (6,35)	1/4 (6,35)
	Gas pipe	Inch (mm)	3/8 (9,52)	3/8 (9,52)	1/2 (12,70)
Pipe length range		m	3 - 20	3 - 20	3 - 20
Elevation difference (in/out) <sup>7)</sup>		m	10	10	15
Pipe length for additional gas		m	7,5	7,5	7,5
Additional gas amount		g/m	10	10	15
Refrigerant (R32) / CO <sub>2</sub> Eq.		kg / T	0,96/0,648	1,00/0,675	1,15/0,776
Operating range	Heat Min ~ Max	°C	-25 ~ +24	-25 ~ +24	-25 ~ +24
	Cool Min ~ Max	°C	-15 ~ +43	-15 ~ +43	-15 ~ +43

### Accessories

<b>CZ-CAPRA1</b>	RAC interface adapter for integration into P-Link
<b>PAW-SMSCONTROL</b>	Control by SMS (need additional SIM card)

### Accessories

<b>CZ-RD514C</b>	Wired remote controller for Wall-mounted and Floor Console
------------------	--

1) COP calculation is based in accordance to EN14511. 2) Capacity of the heat pump is tested with powerful mode with deice mode included. 3) Energy Label Scale from A+++ to D. 4) The annual energy consumption is calculated in accordance to EU/626/2011. 5) The sound pressure of the indoor unit shows the value measured of a position of 1 m in front of the main body and 0,8 m below the unit. For outdoor unit 1 m in front and 1 m in rear side of main body. The sound pressure is measured in accordance with JIS C 9612. Q-Lo: Quiet mode. Lo: The lowest set fan speed. 6) Add 70 mm for piping port. 7) When installing the outdoor unit at a higher position than the indoor unit.



SCOP: For CS-NZ35VKE and CS-NZ50VKE. SEER: For CS-NZ25VKE and CS-NZ50VKE. SUPER QUIET: For CS-NZ25VKE and CS-NZ35VKE. INTERNET CONTROL: Built-in Wi-Fi.

## New Wall-mounted CZ super-compact design

The unit's chassis has been carefully re-designed for simple, stress-free installation and ongoing maintenance.

HEATING  
POSSIBLE AT  
**-25 °C**



### 1 New super-compact design

The new compact design of the indoor units have a width of just 779 mm. This allows for more installation possibilities, including the limited space above a door.

New structure for easier installation and servicing. Installation requires fewer steps and less time.



### 2 High heating capacity and SCOP

CZ series heating capacity has further improved and, thanks to the high SCOP, CZ is a perfect solution to achieve high energy savings while keeping a high level of comfort.

### 3 Perfect for your summer house

Thanks to its +8/+15-degree function, you can keep your summer house, garage, or permit-free auxiliary building frost-free without using a lot of energy.

### 4 Panasonic 1x4. Comfort year-round

With an installation you get an ideal indoor climate all year round: heating even at temperatures as low as -25 °C, or cooling, when the weather gets better.

### Concentrated Airflow for more comfortable cooling

There are now two flaps to enable finer control of air flow direction.

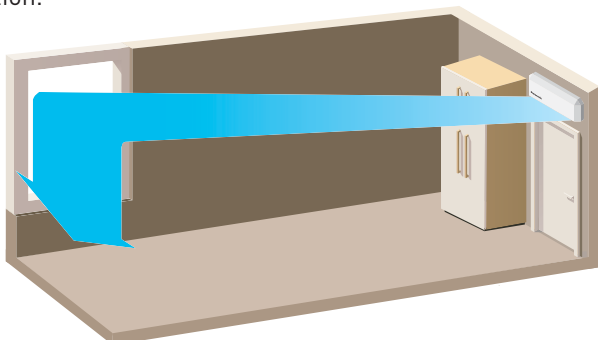

#### Fast cooling.

Aerowings twin flaps direct concentrated airflow downwards to cool you rapidly.

#### Shower cooling.

Shower air flow quickly spreads cool air across a room and up to the walls, and then it showers down gently.

NEW  
2020
**CZ-TACG1**  
Optional Wi-Fi  
Panasonic Comfort  
Cloud for internet  
control.

## New Wall-mounted CZ Inverter • R32 refrigerant

Maximum capacity			5,20 kW	6,70 kW
Indoor unit			CS-CZ25WKE	CS-CZ35WKE
Outdoor unit			CU-CZ25WKE	CU-CZ35WKE
Heating capacity	Nominal (Min - Max)	kW	3,40 (0,85 - 5,20)	4,00 (0,85 - 6,70)
COP <sup>1)</sup>		W/W	4,66	4,08
Heating capacity at -7 °C <sup>2)</sup>		kW	3,30	4,05
COP at -7 °C <sup>1)</sup>		W/W	2,54	2,19
Heating capacity at -15 °C <sup>2)</sup>		kW	2,70	3,60
COP at -15 °C <sup>1)</sup>		W/W	2,25	2,22
Heating capacity at -20 °C <sup>2)</sup>		kW	2,10	3,00
COP at -20 °C <sup>1)</sup>		W/W	1,91	1,90
Heating capacity at -25 °C <sup>2)</sup>		kW	1,50	2,40
COP at -25 °C <sup>1)</sup>		W/W	1,60	1,80
<b>SCOP <sup>3)</sup></b>			<b>4,30 A+</b>	<b>4,30 A+</b>
Pdesign at -10 °C		kW	2,80	3,60
Input power heating	Nominal (Min - Max)	kW	0,73 (0,18 - 1,45)	0,98 (0,18 - 2,00)
Annual energy consumption <sup>4)</sup>		kWh/a	912	1172
Cooling capacity	Nominal (Min - Max)	kW	2,50 (0,85 - 3,00)	3,50 (0,85 - 4,00)
<b>SEER <sup>3)</sup></b>			<b>6,60 A++</b>	<b>6,40 A++</b>
Pdesign (cooling)		kW	2,50	3,50
Input power cooling	Nominal (Min - Max)	kW	0,54 (0,19 - 0,73)	0,94 (0,19 - 1,14)
Annual energy consumption <sup>4)</sup>		kWh/a	133	191
<b>Indoor unit</b>				
Power source		V	230	230
Recommended fuse		A	16	16
Air volume	Heat / Cool	m <sup>3</sup> /min	12,5/11,2	12,8/12,1
Moisture removal volume		l/h	1,5	2,0
Sound pressure <sup>5)</sup>	Heat (Hi / Lo / Q-Lo)	dB(A)	40/27/20	42/33/20
	Cool (Hi / Lo / Q-Lo)	dB(A)	39/25/22	42/28/22
Dimension	H x W x D	mm	290 x 779 x 209	290 x 779 x 209
Net weight		kg	8	8
<b>Outdoor unit</b>				
Air volume	Heat / Cool	m <sup>3</sup> /min	29,7/31,3	30,5/32,9
Sound pressure <sup>5)</sup>	Heat — Cool (Hi / Lo)	dB(A)	47/44 — 46/43	50/47 — 48/45
Dimension <sup>6)</sup>	H x W x D	mm	622 x 824 x 299	622 x 824 x 299
Net weight		kg	33	33
Piping connections	Liquid pipe	Inch (mm)	1/4 (6,35)	1/4 (6,35)
	Gas pipe	Inch (mm)	3/8 (9,52)	3/8 (9,52)
Pipe length range		m	3 ~ 20	3 ~ 20
Elevation difference (in/out) <sup>7)</sup>		m	10	10
Pipe length for additional gas		m	7,5	7,5
Additional gas amount		g/m	10	10
Refrigerant (R32) / CO <sub>2</sub> Eq.		kg / T	0,84 / 0,567	0,84 / 0,567
Operating range	Heat Min ~ Max	°C	-25 ~ +24	-25 ~ +24
	Cool Min ~ Max	°C	+16 ~ +43	+16 ~ +43

### Accessories

<b>CZ-TACG1</b>	Panasonic Comfort Cloud for internet control
<b>CZ-CAPRA1</b>	RAC interface adapter for integration into P-Link

### Accessories

<b>PAW-SMSCONTROL</b>	Control by SMS (need additional SIM card)
<b>CZ-RD514C</b>	Wired remote controller for Wall-mounted and Floor Console

1) COP calculation is based in accordance to EN14511. 2) Capacity of the heat pump is tested with powerful mode with deice mode included. 3) Energy Label Scale from A+++ to D. 4) The annual energy consumption is calculated in accordance to EU/626/2011. 5) The sound pressure of the indoor unit shows the value measured of a position of 1 m in front of the main body and 0,8 m below the unit. For outdoor unit 1 m in front and 1 m in rear side of main body. The sound pressure is measured in accordance with JIS C 9612. Q-Lo: Quiet mode. Lo: The lowest set fan speed. 6) Add 70 mm for piping port. 7) When installing the outdoor unit at a higher position than the indoor unit.

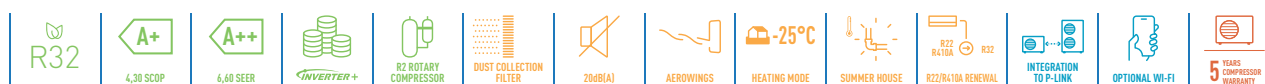

SCOP and SEER: For CS-CZ25WKE. INTERNET CONTROL: Optional.

# Floor Console. Efficient comfort and clean air all year round

Floor Console with new nanoe™ X technology: outstanding efficiency A++, comfort (Super Quiet technology only 20 dB(A)) and healthy air combined in a breakthrough design.



The iF Product Design Awards are among the most prestigious awards for product design excellence. Winning the award thanks to its highly intelligent functionality, the Panasonic Floor Console is the ideal air-conditioning system for domestic and commercial applications.

**1 Cleaner air with nanoe™ X**  nanoe™ X is an outstanding technology with much higher performance for better indoor air quality.

**2 Superquiet operation** When the system reaches its set temperature, the unit will operate at only 20 dB(A). Creating a comfortable home is not only by temperature - a quiet atmosphere is also important.

**3 Designed to follow the high European demands** Superquiet operation, highly efficient and technology to help clean the air.

**4 Stylish infrared control** Enjoy innovative design at your fingertips with the new stylish and sleek Backlit Sky Controller. Bigger screen and easier to use.

## Easy to integrate into your home

A breakthrough design that integrates perfectly with any style. We have carefully selected materials and processes to create an elegant design. Compact in size and with a stylish design, the new Floor Console will easily integrate into your home's interior decoration. There are four options available:



## The perfect solution for the replacement of old boiler heating systems



## High Energy efficiency class A++

Heat pump brings the outdoor heat energy inside. The floor console can provide heat inside even when it is -15 °C outside.

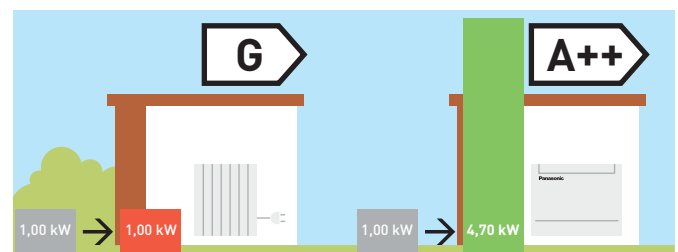

\* SCOP on heating mode for CS-Z25UFEAW-1 compared with electrical heaters at +7 °C.



**CZ-TACG1**  
Optional Wi-Fi  
Panasonic Comfort  
Cloud for internet  
control.

## Floor Console Inverter+ • R32 refrigerant

Maximum capacity			5,50 kW	6,20 kW
Indoor unit			CS-Z25UFEAW-1	CS-Z35UFEAW-1
Outdoor unit			CU-Z25UFEA-1	CU-Z35UFEA-1
Heating capacity	Nominal (Min - Max)	kW	3,40 (0,85 - 5,50)	4,30 (0,85 - 6,20)
COP <sup>1)</sup>		W/W	4,59	4,06
Heating capacity at -7 °C <sup>2)</sup>		kW	3,80	4,20
COP at -7 °C <sup>1)</sup>		W/W	2,53	2,33
Heating capacity at -15 °C <sup>2)</sup>		kW	3,50	3,90
COP at -15 °C <sup>1)</sup>		W/W	2,30	2,15
Heating capacity at -20 °C <sup>2)</sup>		kW	2,90	3,30
COP at -20 °C <sup>1)</sup>		W/W	1,96	1,94
Heating capacity at -25 °C <sup>2)</sup>		kW	2,40	2,85
COP at -25 °C <sup>1)</sup>		W/W	1,68	1,73
<b>SCOP <sup>3)</sup></b>			<b>4,70 A++</b>	<b>4,60 A++</b>
SCOP tested by 3rd party laboratory DTI <sup>4)</sup>			4,79 <sup>4)</sup>	—
Pdesign at -10 °C		kW	3,00	3,60
Input power heating	Nominal (Min - Max)	kW	0,74 (0,17 - 1,51)	1,06 (0,17 - 1,83)
Annual energy consumption <sup>5)</sup>		kWh/a	894	1096
Cooling capacity	Nominal (Min - Max)	kW	2,50 (0,85 - 3,40)	3,50 (0,85 - 3,80)
<b>SEER <sup>3)</sup></b>			<b>8,10 A++</b>	<b>7,80 A++</b>
Pdesign (cooling)		kW	2,50	3,50
Input power cooling	Nominal (Min - Max)	kW	0,51 (0,17 - 0,88)	0,84 (0,17 - 1,04)
Annual energy consumption <sup>5)</sup>		kWh/a	108	157
<b>Indoor unit</b>				
Air volume	Heat / Cool	m <sup>3</sup> /min	9,9/9,6	10,1/9,9
Moisture removal volume		L/h	1,5	2,0
Sound pressure <sup>6)</sup>	Heat (Hi / Lo / Q-Lo)	dB(A)	38/25/19	39/26/19
	Cool (Hi / Lo / Q-Lo)	dB(A)	38/25/20	39/26/20
Dimension	H x W x D	mm	600 x 750 x 207	600 x 750 x 207
Net weight		kg	13	13
nanoe X Generator			Mark 1	Mark 1
<b>Outdoor unit</b>				
Power source		V	230	230
Recommended fuse		A	10	10
Air volume	Heat / Cool	m <sup>3</sup> /min	32,2/32,2	34,4/32,7
Sound pressure <sup>6)</sup>	Heat — Cool (Hi / Lo)	dB(A)	48/45 — 46/43	50/47 — 48/45
Dimension <sup>7)</sup>	H x W x D	mm	622 x 824 x 299	622 x 824 x 299
Net weight		kg	34	37
Piping connections	Liquid pipe	Inch (mm)	1/4 (6,35)	1/4 (6,35)
	Gas pipe	Inch (mm)	3/8 (9,52)	3/8 (9,52)
Pipe length range		m	3 - 20	3 - 20
Elevation difference (in/out) <sup>8)</sup>		m	15	15
Pipe length for additional gas		m	7,5	7,5
Additional gas amount		g/m	10	10
Refrigerant (R32) / CO <sub>2</sub> Eq.		kg / T	0,97/0,65475	1,07/0,72225
Operating range	Heat Min - Max	°C	-25 ~ +24	-25 ~ +24
	Cool Min - Max	°C	-15 ~ +43	-15 ~ +43
Lowest outdoor temperature tested by 3rd party laboratory <sup>9)</sup>		°C	-35	—

### Accessories

<b>CZ-TACG1</b>	Panasonic Comfort Cloud for internet control
<b>CZ-CAPRA1</b>	RAC interface adapter for integration into P-Link

### Accessories

<b>CZ-RD514C</b>	Wired remote controller for Wall-mounted and Floor Console
------------------	--

1) COP calculation is based in accordance to EN14511. 2) Capacity of the heat pump is tested with powerful mode with deice mode included. 3) Energy Label Scale from A+++ to D. 4) SCOP Tested by 3rd Party laboratory DTI under EN14825:2016. 5) The annual energy consumption is calculated in accordance to EU/626/2011. 6) The sound pressure of the units shows the value measured of a position 1 m in front of the main body and 1 m above floor. The sound pressure is measured in accordance with JIS C 9612. Q-Lo: Quiet mode. Lo: The lowest set fan speed. 7) Add 70 mm for piping port. 8) When installing the outdoor unit at a higher position than the indoor unit. 9) Tested by 3rd party laboratory, DTI, according to EN14511:2013, this temperature is not guaranteed by Factory.



SCOP and SEER: For CS-Z25UFEAW-1. -35 °C HEATING MODE: For CS-Z25UFEAW-1 heating performance tested at -35 °C by DTI, European 3rd party laboratory. INTERNET CONTROL: Optional.

# Control and Connectivity

Panasonic offers its customers cutting-edge technology, specially designed to ensure our air conditioning systems deliver even higher performance.

You can properly manage the air conditioning and perform comprehensive monitoring and control, with all of the features the remote controller provides at home, from anywhere in the world thanks to the internet applications Panasonic has created for you.

## Domestic integration to P-Link - CZ-CAPRA1

Can connect RAC range to P-Link. Full control is now possible.

### Integrates any unit in big system control.

- TKEA server room integration
- Small offices with domestic indoors
- Tender for refurbishment (old system domestic and VRF in one installation)

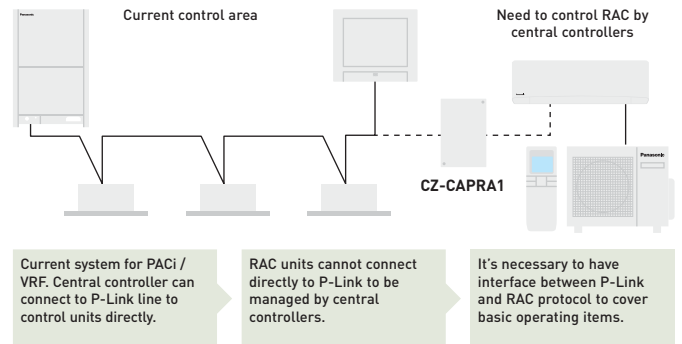

**Basic operation items:** ON/OFF, Mode select, Temperature setting, Fan speed, Flap setting, Remote control prohibit.  
**External input:** ON/OFF control signal, Abnormal stop signal.  
**External output for Relay <sup>1)</sup>:** Operation status (ON/OFF), Alarm status output.

<sup>1)</sup> Because current CN-CNT connector can not provide the power for external output relay, additional Input power for external relay is necessary.

## Connectivity. Control by BMS

Great flexibility for integration into your KNX, Modbus and BACnet projects allows fully bi-directional monitoring and control of all the functioning parameters.

Reference	KNX <sup>®</sup> PAW-AC-KNX-1i	Modbus <sup>®</sup> PAW-AC-MBS-1	BACnet <sup>™</sup> PAW-AC-BAC-1 <sup>1)</sup>
Quick installation and possibility of hidden installation	✓	✓	✓
External power not required	✓	✓	✓
Direct connection to the AC indoor unit	✓ (Split or Multi Split)	✓ (Split or Multi Split)	✓
Control and monitoring of the internal variables of the indoor unit and error codes and indication	✓ Fully compatible	✓ Fully compatible	
Use the AC ambient temperature or the one measured by external sensor	✓	✓	
AC unit can be controlled simultaneously by the remote controller of the AC unit and interface devices	✓	✓	
Advanced control functions	✓	✓	
4 binary inputs. They work as standard interface binary inputs as well as being used to control the AC directly	✓	✓	
Total Control and Supervision. Real states of the AC unit's internal variables			✓

<sup>1)</sup> This interface allows a complete and natural integration of Panasonic air conditioners into either BACnet IP or MS/TP networks. Is a BTL certified device.

## PAW-AC-DIO

Dry contact ON/OFF Interface. Panasonic has developed for hotels applications a dry contact PCB which works with Etherea, RE, UE and YE indoor units in order to control simply the unit centrally.

- ON/OFF signal by 3rd party BMS
- PCB connected to CN-RMT port on indoor unit PCB

Model name	Interface
CZ-TACG1	Panasonic Comfort Cloud for internet control
CZ-CAPRA1	RAC interface adapter for integration into P-Link, plus external input and alarm/status output
PAW-AC-KNX-1i	This interface can be used with all models which have a CN-CNT connector
PAW-AC-MBS-1	This interface can be used with all models which have a CN-CNT connector
PAW-AC-BAC-1	This interface can be used with all models which have a CN-CNT connector

Model name	Interface
PAW-AC-HEAT-1	Heating only PCB for Etherea, 4-Way 60x60 Cassette and Low static pressure hide away
PAW-AC-DIO	This interface can be used with all models which have a CN-RMT connector
PAW-SMSPCONTROL	Control of the Etherea, Flagship and Heatcharge by SMS (need additional SIM card)

# Accessories and control

## Optional PCB's for additional functions



**CZ-TACG1**  
Panasonic Comfort Cloud for internet control.



**CZ-CAPRA1**  
RAC interface adapter for integration into P-Link, plus external input and alarm/status output.



**PAW-AC-KNX-1i**  
This interface can be used with all models which have a CN-CNT connector.



**PAW-AC-MBS-1**  
This interface can be used with all models which have a CN-CNT connector.



**PAW-AC-BAC-1**  
This interface can be used with all models which have a CN-CNT connector.



**PAW-AC-DIO**  
This interface can be used with all models which have a CN-RMT connector.



**PAW-AC-HEAT-1**  
Heating only PCB for Etherea, 4 Way 60x60 Cassette and Hide Away.



**PAW-SMSCONTROL**  
Control of the Etherea, Flagship and Heatcharge by SMS (need additional SIM card).

## Individual Controls



**CZ-RD514C**  
Wired remote controller for Wall-mounted and Floor Console.

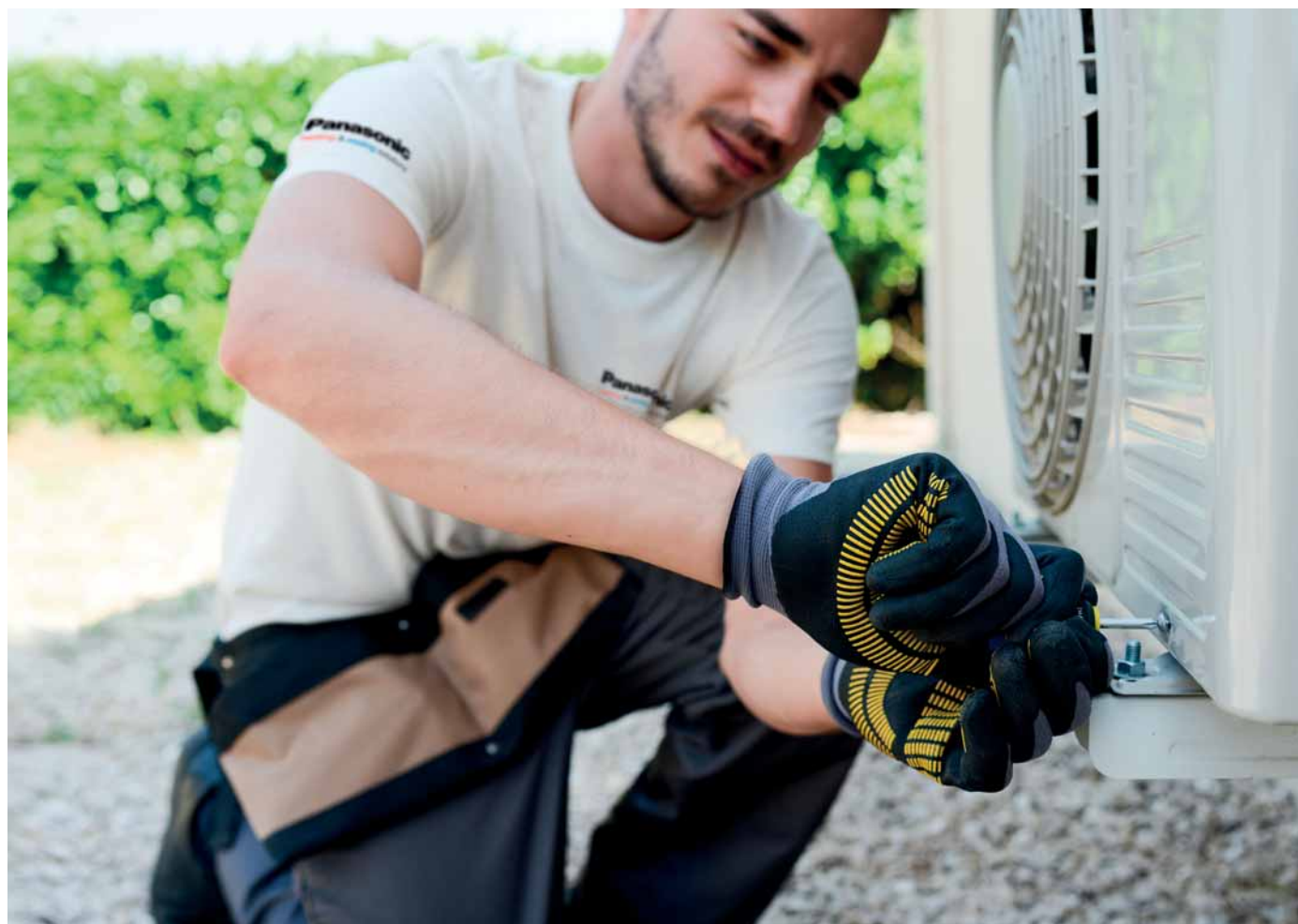



## Panasonic Commercial air to air

Here are some of your new air conditioner's major features.

Panasonic has developed an impressive range of highly efficient Commercial Air Conditioners. This range confirms our commitment to the environment, with our highly efficient inverter compressor technology to optimise performance.



## Panasonic PACi R32 up to 25,0 kW.

Panasonic PACi provides a wide range of heating & cooling solutions with R32 refrigerant from 3,6 to 25,0 kW. From residential to commercial applications, it's the low GWP solution.



## New wired remote controller.

Panasonic has developed the new wired remote controller to meet the modern control needs. The controller provides great accessibility and convenient tools in a stylish design.

## nanoe™ X with PACi 90x90 Cassette.

Thanks to advances in design and technology such as the new high performance turbo fan, which is more efficient and silent, the nanoe™ X air cleaner which provides healthy air, the floor temperature and humidity sensor (provided by Econavi) that gives more control, the new PU2 Panasonic 90 x 90 4 Way Cassette provides a high-class solution for energy savings, healthy environment and comfort.



## R32 Big PACi with a Split-able Hide Away indoor.

New Hide Away indoor. The new light weight and compact body design can be split into 3 components, providing simplified installation within a space with narrow access. IoT solutions by Panasonic such as Panasonic Comfort Cloud control and AC Smart Cloud are both available in this range.

## Highly-Efficient Water Heat Exchanger for PACi series.

This ground-breaking product gives further possibilities of PACi solutions by adding hydronic options. Providing not only an efficient operation with A++ Energy efficiency class\*, but also 2 installation configurations (Wall-mounted and Floor-standing) meeting the needs of various spaces.

\* Scale from A+++ to D.



## Innovative solutions for retail

### Heating and cooling solutions for retail applications

Panasonic has developed solutions for retail applications and office applications where return on investment is a key factor! The comfort inside the shop is key for a good customer experience in the shop.

From local control or from Panasonic new cloud control system, a detail status of the heating and cooling system can be displayed, analysed and optimised in order to improve the efficiency, reduce the running time and increase the life time of the units.

### 8 reason why Panasonic is the best solution for your retail:

- Complete solution
- Flexibility and adaptation
- Go green retail: low CO<sub>2</sub> emissions
- Comfort - high customer satisfaction
- Future expansion
- Panasonic offers efficient systems meeting expectations over the years
- High quality of service with Panasonic pro-partner installation team
- The system will still operate up to 25 % of the connected indoor units. System will not stop when up to 25 % of indoor units have power supply breakdown when they are on mode

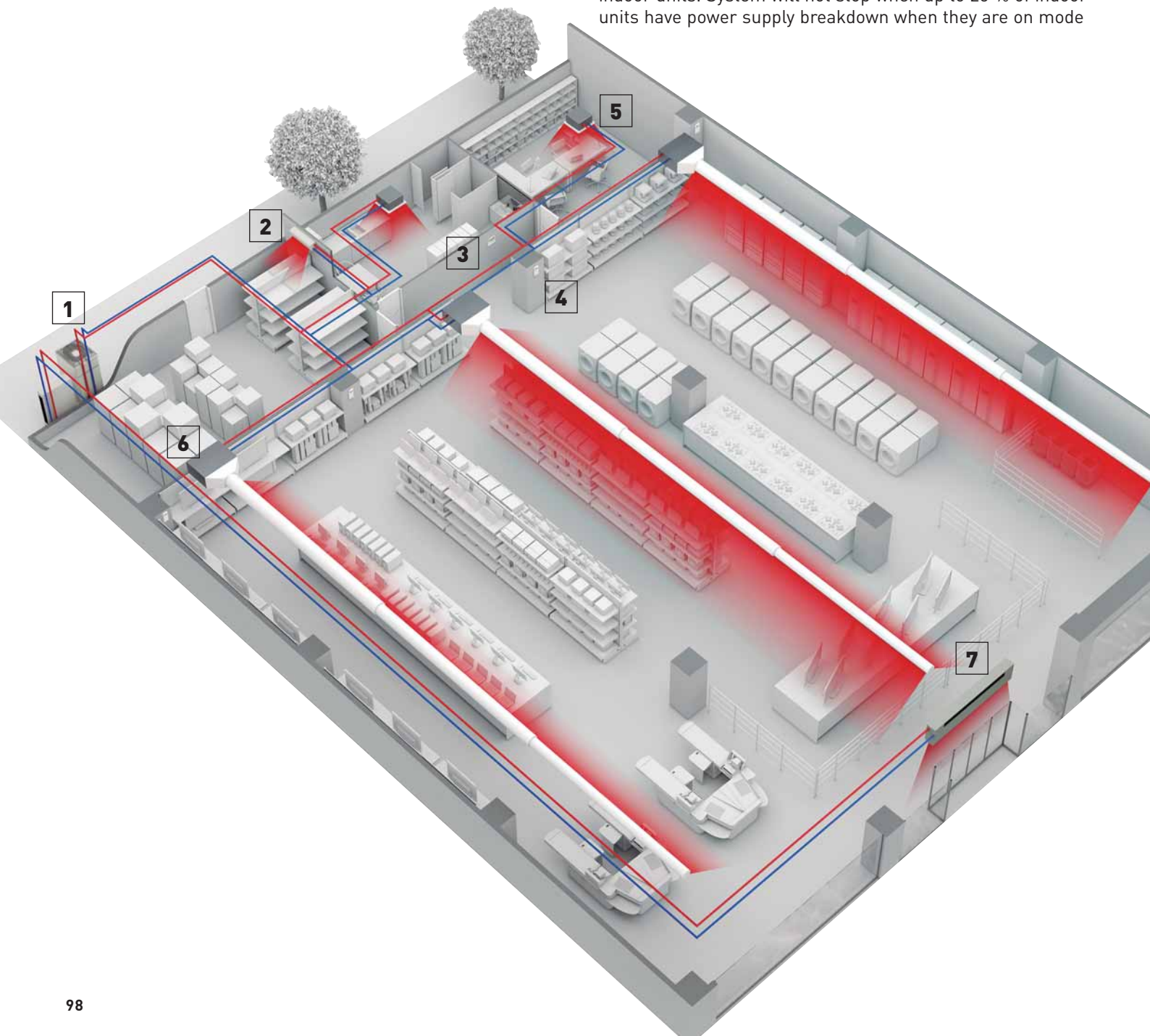



**Multi energy solutions, gas or electric.**

The Multi energy solution (Gas and Electric) from Panasonic provides the best choice in energy saving and on the flexibility of the installation. Panasonic solutions can be connect to direct expansion systems, water chiller installations and ventilation systems as air handling units.

- 1a: Electric VRF. ECOi
- 1b: Electric VRF. Mini ECOi
- 1c: Electric 1x1. PACi
- 1d: Electric A2W. Aquarea



**TKEA outdoor unit for server room.**

Steady cooling, nonstop, even at -20 °C and still with high efficiency. Ready for continuous operation and easy to connect 2 systems to automatically alternate and ensure server rooms are kept cool with maximum operating guaranteed.



**Control your way.**

Wide variety of controls, from simple user control to full system control via remote access functionality. Touch panel and consumption control.



**Econavi Sensor.**

The Econavi Sensor detects presence in the room, and quietly adapts the PACi or VRF air conditioning system in order to improve comfort and energy savings.



**Wide range of indoor units.**

Complete range of indoor units that fits any need. All units provided with supply air temperature sensor and low operation sound level to guarantee guests comfort. From 1,5 kW up to 30,0 kW.



**Hide Away, for power and efficiency.**

Super silent units deliver the ideal air supply. Units available from 1,5 kW providing precise temperature control even in small rooms. Two models available: slim unit for height restricted areas (MM unit only 200 mm deep), another which allows 100 % fresh air (MF).

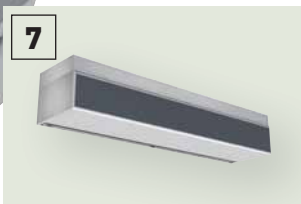

**Air Curtain with DX Coil.**

The Panasonic range of air curtains is designed for smooth operation and efficient performance.



**Protocol friendly.**

Great flexibility for integration into your KNX / Modbus / LonWorks / BACnet projects allows fully bi-directional monitoring and control of all the functioning parameters. Range of solutions to control locally or remotely the full system in bi-directional mode.



**Air Handling Unit kits for efficient ventilation.**

The new AHU kit is specially designed to improve the efficiency of the pre-heating or pre-cooling process of the ventilation.

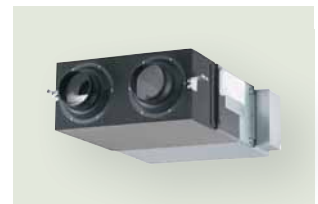

**Energy Recovery unit for high efficiency of the system.**

Panasonic Energy Recovery Ventilators can reduce the outside air load because they efficiently recover the heat lost by ventilation during the heat recovery process.

## Free Multi System

If air conditioning requirements exceed the ambit of a single room, Panasonic offers an extensive range of possibilities with up to 5 indoor units connected to a single outdoor unit.



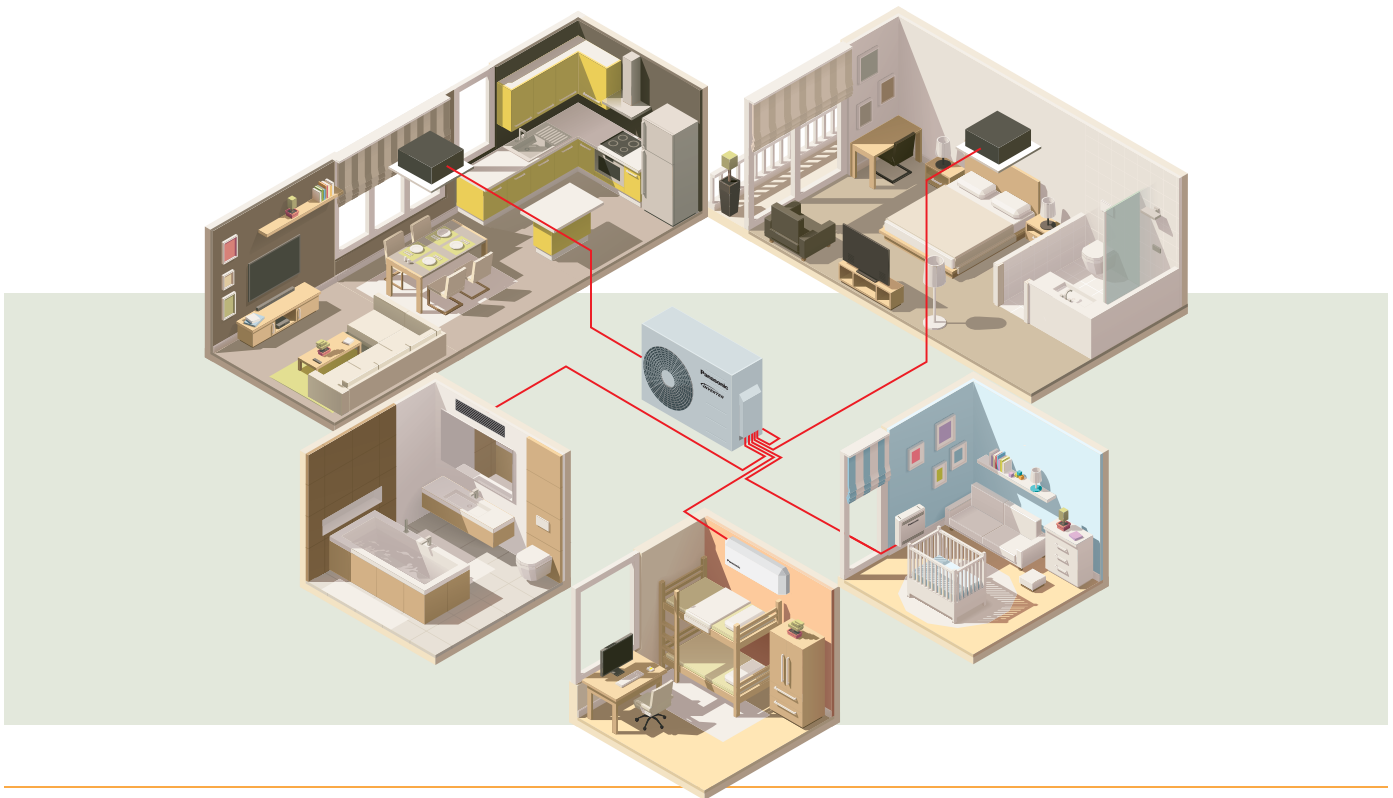

### Panasonic offers widest range in Multi Split systems

2 types of Multi Split range from 3,5 to 9,0 kW for 5 indoor units with one outdoor unit.

#### Free Multi Z

Full flexibility up to 9,0 kW and up to 5 ports with wide range of indoor units including high performance Etherea indoor units, reaching up to A+++ / A++

### Why a Multi Split is better than several separate split units

#### Up to 5 indoor units with a single outdoor unit.

- Just one compact outdoor unit
- Increased comfort in the house since every room has its own indoor unit for heating
- Much more powerful than a single split

- More efficient since the units are always operating at full capacity
- You can connect all types of indoor units, such as wall types and consoles, depending on what suits your house best

#### Solution with single split.

One indoor unit is connected to one outdoor unit. The indoor unit is placed in the main hallway and heats the entire house. Certain rooms may not be perfectly heated, which causes inadequate comfort.

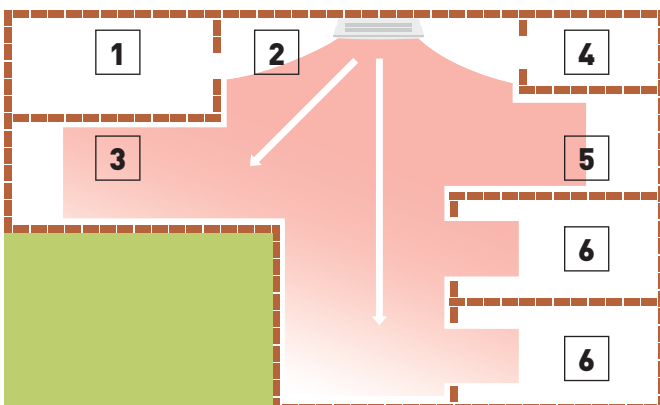

1. Laundry room. 2. Entrance. 3. Kitchen/dining area. 4. Bathroom. 5. Living room. 6. Bedroom.

#### Solution with Multi Split.

With one outdoor unit, you can connect up to five indoor units. There is one indoor unit per room or area. It gives an extreme increase in comfort levels. On the roof, there is only one outdoor unit.

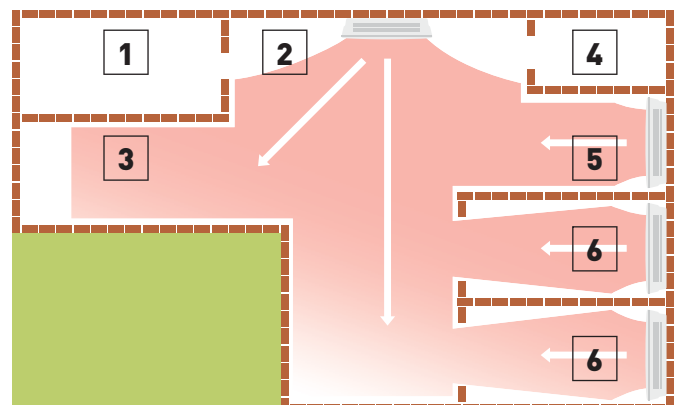



**Outdoor unit Free Multi System Z • R32 refrigerant**

Indoor nominal capacity (Min - Max)			3,2~6,0 kW	3,2~6,0 kW	3,2~7,7 kW	4,5~9,5 kW	4,5~11,2 kW	4,5~11,5 kW	4,5~14,7 kW	4,5~18,3 kW
Unit			CU-2Z35TBE	CU-2Z41TBE	CU-2Z50TBE	CU-3Z52TBE	CU-3Z68TBE	CU-4Z68TBE	CU-4Z80TBE	CU-5Z90TBE
Cooling capacity	Nominal (Min - Max)	kW	3,50(1,50-4,50)	4,10(1,50-5,20)	5,00(1,50-5,40)	5,20(1,80-7,30)	6,80(1,90-8,00)	6,80(1,90-8,80)	8,00(3,00-9,20)	9,00(2,90-11,50)
EER <sup>1)</sup>	Nominal (Min - Max)	W/W	4,86(6,00-4,09)	4,56(6,00-3,80)	4,24(6,00-3,62)	4,77	3,66(7,04-3,38)	4,39(5,59-3,56)	4,04(5,66-3,21)	4,09(5,27-2,98)
SEER <sup>2)</sup>			8,50 A+++	8,50 A+++	8,50 A+++	8,50 A+++	8,00 A++	8,00 A++	7,90 A++	8,50 A+++
Pdesign (cooling)		kW	3,50	4,10	5,00	5,20	6,80	6,80	8,00	9,00
Input power cooling	Nominal (Min - Max)	kW	0,72(0,25-1,10)	0,90(0,25-1,37)	1,18(0,25-1,49)	1,09(0,36-2,18)	1,86(0,27-2,37)	1,55(0,34-2,47)	1,98(0,53-2,87)	2,20(0,55-3,86)
Annual energy consumption <sup>3)</sup>		kWh/a	144	169	206	214	298	298	990	1100
Heating capacity	Nominal (Min - Max)	kW	4,20(1,10-5,60)	4,60(1,10-7,00)	5,60(1,10-7,20)	6,80(1,60-8,30)	8,50(3,30-10,40)	8,50(3,00-10,60)	9,40(4,20-10,60)	10,40(3,40-14,50)
Heating capacity at -7 °C		kW	—	—	—	3,95	4,45	4,45	—	—
COP <sup>1)</sup>	Nominal (Min - Max)	W/W	4,88(5,24-4,18)	4,79(5,24-3,91)	4,63(5,24-4,00)	4,63(5,00-3,82)	3,95(5,32-3,64)	4,47(5,17-3,96)	4,63(6,00-3,46)	4,84(6,42-3,42)
SCOP <sup>2)</sup>			4,60 A++	4,60 A++	4,60 A++	4,20 A+	4,20 A+	4,20 A+	4,70 A++	4,68 A++
Pdesign at -10 °C		kW	3,20	3,50	4,20	5,00	5,20	5,80	6,80	8,50
Input power heating	Nominal (Min - Max)	kW	0,86(0,21-1,34)	0,96(0,21-1,79)	1,21(0,21-1,80)	1,47(0,32-2,17)	2,15(0,62-2,86)	1,90(0,58-2,68)	2,03(0,70-3,06)	2,15(0,53-4,24)
Annual energy consumption <sup>3)</sup>		kWh/a	974	1065	1278	1667	1733	1933	2026	2543
Current	Cool / Heat	A	3,35/4,00	4,15/4,45	5,35/5,50	5,00/6,70	8,40/9,70	7,00/8,60	9,50/9,50	10,50/10,10
Power source		V	230	230	230	230	230	230	230	230
Recommended fuse		A	16	16	16	16	16	20	20	25
Recommended power cable section		mm <sup>2</sup>	2,5	2,5	2,5	2,5	2,5	2,5	2,5	3,5
Sound pressure <sup>4)</sup>	Cool / Heat (Hi)	dB(A)	48/50	48/50	50/52	47/48	51/52	49/50	51/52	53/54
Dimension <sup>5)</sup>	H x W x D	mm	619 x 824 x 299	619 x 824 x 299	619 x 824 x 299	795 x 875 x 320	795 x 875 x 320	795 x 875 x 320	999 x 940 x 340	999 x 940 x 340
Net weight		kg	39	39	39	71	71	72	80	81
Piping connections	Liquid pipe	Inch (mm)	1/4(6,35)	1/4(6,35)	1/4(6,35)	1/4(6,35)	1/4(6,35)	1/4(6,35)	1/4(6,35)	1/4(6,35)
	Gas pipe	Inch (mm)	3/8(9,52)	3/8(9,52)	3/8(9,52)	3/8(9,52)	3/8(9,52)	3/8(9,52)	3/8(9,52)	3/8(9,52)
Pipe length range total <sup>6)</sup>		m	6~30	6~30	6~30	6~50	6~60	6~60	6~70	6~80
Pipe length range to one unit		m	3~20	3~20	3~20	3~25	3~25	3~25	3~25	3~25
Elevation difference (in/out)		m	10	10	10	15	15	15	15	15
Pipe length for additional gas		m	20	20	20	30	30	30	45	45
Additional gas amount		g/m	15	15	15	20	20	20	20	20
Refrigerant (R32) / CO <sub>2</sub> Eq.		kg / T	1,12/0,756	1,12/0,756	1,12/0,756	2,10/1,418	2,10/1,418	2,10/1,418	2,72/1,836	2,72/1,836
Operating range	Cool Min ~ Max	°C	-10~+46	-10~+46	-10~+46	-10~+46	-10~+46	-10~+46	-10~+46	-10~+46
	Heat Min ~ Max	°C	-15~+24	-15~+24	-15~+24	-15~+24	-15~+24	-15~+24	-15~+24	-15~+24

1) EER and COP calculation is based in accordance to EN14511. 2) Energy Label Scale from A+++ to D. 3) The annual energy consumption is calculated in accordance to EU/626/2011. 4) The sound pressure of the units shows the value measured of a position 1 m in front and 1 m in rear side of the main body. The sound pressure is measured in accordance with JIS C 9612. 5) Add 70 or 95 mm for piping port. 6) Minimum piping length is 3 meters per indoor unit.

**Possible outdoor / indoor units combinations • R32 refrigerant**

Rooms	Model	Indoor capacity connected (Min - Max)	NEW Wall-mounted TZ super-compact							Floor Console*							4 Way 60x60 Cassette							Low Static Pressure Hide Away													
			16	20	25	35	42	50	60	71	16	20	25	35	42	50	60	71	16	20	25	35	42	50	60	71	16	20	25	35	42	50	60	71			
2	CU-2Z35TBE	3,2~6,0 kW	✓	✓	✓	✓	✓	✓	✓	✓	✓							✓	✓	✓										✓	✓	✓					
	CU-2Z41TBE	3,2~6,0 kW	✓	✓	✓	✓	✓	✓	✓	✓	✓							✓	✓	✓										✓	✓	✓					
	CU-2Z50TBE	3,2~7,7 kW	✓	✓	✓	✓	✓ <sup>1)</sup>	✓ <sup>1)</sup>	✓	✓	✓	✓						✓	✓	✓	✓ <sup>1)</sup>									✓	✓	✓	✓ <sup>1)</sup>				
3	CU-3Z52TBE	4,5~9,5 kW	✓	✓	✓	✓	✓ <sup>1)</sup>	✓ <sup>1)</sup>	✓	✓	✓						✓	✓	✓	✓ <sup>1)</sup>									✓	✓	✓	✓ <sup>1)</sup>					
	CU-3Z68TBE	4,5~11,2 kW	✓	✓	✓	✓	✓ <sup>1)</sup>	✓ <sup>1)</sup>	✓ <sup>1)</sup>	✓	✓						✓	✓	✓	✓ <sup>1)</sup>	✓ <sup>1)</sup>								✓	✓	✓	✓ <sup>1)</sup>	✓ <sup>1)</sup>				
4	CU-4Z68TBE	4,5~11,5 kW	✓	✓	✓	✓	✓ <sup>1)</sup>	✓ <sup>1)</sup>	✓ <sup>1)</sup>	✓	✓						✓	✓	✓	✓ <sup>1)</sup>	✓ <sup>1)</sup>								✓	✓	✓	✓ <sup>1)</sup>	✓ <sup>1)</sup>				
	CU-4Z80TBE	4,5~14,7 kW	✓	✓	✓	✓	✓ <sup>1)</sup>	✓ <sup>1)</sup>	✓ <sup>1)</sup>	✓	✓						✓	✓	✓	✓ <sup>1)</sup>	✓ <sup>1)</sup>	✓ <sup>1)</sup>							✓	✓	✓	✓ <sup>1)</sup>	✓ <sup>1)</sup>	✓ <sup>1)</sup>			
5	CU-5Z90TBE	4,5~18,3 kW	✓	✓	✓	✓	✓ <sup>1)</sup>	✓ <sup>1)</sup>	✓ <sup>1)</sup>	✓	✓						✓	✓	✓	✓ <sup>1)</sup>	✓ <sup>1)</sup>	✓ <sup>1)</sup>							✓	✓	✓	✓ <sup>1)</sup>	✓ <sup>1)</sup>	✓ <sup>1)</sup>			

1) A CZ-MA1P pipe reducer is needed on the 42 and 50, a CZ-MA2P pipe expander is needed on the 60 and 71, and CZ-MA3P pipe reducer on the 71.

\* Compatible only with 2 ports R32 outdoor CU-2Z35TBE / CU-2Z41TBE / CU-2Z50TBE. Minimum quantity of connection: 2 indoor units. Floor console indoor unit is compatible with R410A outdoors with 3, 4 or 5 ports: CU-3E18PBE, CU-3E23SBE, CU-4E23PBE, CU-4E27PBE and CU-5E34PBE.

**Outdoor Multi combination model**

	Model
CS-MTZ16WKE CS-TZ20WKEW / CS-MZ20UFEA / CS-MZ20UB4EA / CS-MZ20UD3EA CS-TZ25WKEW / CS-Z25UFEAW / CS-Z25UB4EAW / CS-Z25UD3EAW CS-TZ35WKEW / CS-Z35UFEAW / CS-Z35UB4EAW / CS-Z35UD3EAW	CU-2Z35TBE / CU-2Z41TBE / CU-2Z50TBE / CU-3Z52TBE / CU-3Z68TBE / CU-4Z68TBE / CU-4Z80TBE / CU-5Z90TBE
CS-TZ42WKEW CS-TZ50WKEW / CS-Z50UFEAW / CS-Z50UB4EAW / CS-Z50UD3EAW	CU-2Z50TBE / CU-3Z52TBE / CU-3Z68TBE / CU-4Z68TBE / CU-4Z80TBE / CU-5Z90TBE
CS-TZ60WKEW / CS-Z60UB4EAW / CS-Z60UD3EAW	CU-3Z68TBE / CU-4Z68TBE / CU-4Z80TBE / CU-5Z90TBE
CS-TZ71WKEW	CU-4Z80TBE / CU-5Z90TBE

\* For CZ-MA3P necessary to use adaptor CZ-MA2P too.



CZ-MA1P is to be used to reduce the connection size on the indoor unit from 1/2" to 3/8".

CZ-MA2P is to be used to increase the connection size on the outdoor unit from 3/8" to 1/2".

CZ-MA3P is to be used to reduce the connection size on the indoor unit from 5/8" to 1/2".



**CZ-RD514C**  
Optional wired  
remote  
controller.

NEW  
2020

INTERNET CONTROL:  
Built-in Wi-Fi.



NEW Wall-mounted TZ super-compact	Indoor unit	Cooling capacity	Heating capacity	Connection in. / out.	Sound pressure <sup>1)</sup>		Dimension / Net weight		Piping connections	
					Cool — Heat (Hi/Lo/S-Lo)		HxWxD		Liquid / Gas pipe	
					dB(A)		mm / kg		Inch (mm)	
1,6 kW*	CS-MTZ16WKE	1,60	2,60	4 x 1,5	38/27/22 — 39/28/24		290 x 779 x 209 / 8		1/4 (6,35) / 3/8 (9,52)	
2,0 kW	CS-TZ20WKEW	2,00	2,70	4 x 1,5	37/25/20 — 38/26/22		290 x 779 x 209 / 8		1/4 (6,35) / 3/8 (9,52)	
2,5 kW	CS-TZ25WKEW	2,50	3,30	4 x 1,5	40/26/20 — 40/27/22		290 x 779 x 209 / 8		1/4 (6,35) / 3/8 (9,52)	
3,5 kW <sup>2)</sup>	CS-TZ35WKEW	3,50	4,00	4 x 1,5	42/30/20 — 42/33/22		290 x 779 x 209 / 8		1/4 (6,35) / 3/8 (9,52)	
4,2 kW	CS-TZ42WKEW	4,20	5,00	4 x 1,5	44/31/29 — 44/35/34		290 x 779 x 209 / 8		1/4 (6,35) / 1/2 (12,70)	
5,0 kW	CS-TZ50WKEW	5,00	5,80	4 x 2,5	44/37/33 — 44/37/33		290 x 779 x 209 / 8		1/4 (6,35) / 1/2 (12,70)	
6,0 kW	CS-TZ60WKEW	6,00	7,00	4 x 2,5	45/37/34 — 45/37/34		302 x 1102 x 244 / 13		1/4 (6,35) / 1/2 (12,70)	
7,1 kW	CS-TZ71WKEW	7,10	8,60	4 x 2,5	47/38/35 — 47/38/35		302 x 1102 x 244 / 13		1/4 (6,35) / 5/8 (15,88)	



**CZ-RD514C**  
Optional wired  
remote  
controller.

INTERNET CONTROL: Optional.



Floor Console <sup>3)</sup>	Indoor unit	Cooling capacity	Heating capacity	Connection in. / out.	Sound pressure <sup>4)</sup>		Dimension / Net weight		Piping connections	
					Cool — Heat (Hi/Lo/S-Lo)		HxWxD		Liquid / Gas pipe	
					dB(A)		mm / kg		Inch (mm)	
2,5 kW	CS-Z25UFEAW-1	2,50	3,60	4 x 1,5	38/25/20 — 38/25/19		600 x 750 x 207 / 13		1/4 (6,35) / 3/8 (9,52)	
3,5 kW <sup>2)</sup>	CS-Z35UFEAW-1	3,50	4,50	4 x 1,5	39/26/20 — 39/26/19		600 x 750 x 207 / 13		1/4 (6,35) / 3/8 (9,52)	



**CZ-BT20EW**  
RAL9010 panel for 4  
Way 60x60 Cassette  
(sold separately).



**CZ-RD52CP**  
Optional wired  
remote  
controller.

INTERNET CONTROL and BMS CONNECTIVITY: Optional.



4 Way 60x60 Cassette	Indoor unit (Panel CZ-BT20EW)	Cooling capacity	Heating capacity	Connection in. / out.	Sound pressure <sup>4)</sup>		Dimension / Net weight		Piping connections	
					Cool — Heat (Hi/Lo/S-Lo)		Indoor HxWxD		Liquid / Gas pipe	
					dB(A)		mm / kg		Inch (mm)	
2,0 kW	CS-MZ20UB4EA	2,00	3,20	4 x 1,5	35/27/24 — 36/30/27		260 x 575 x 575 / 18		1/4 (6,35) / 3/8 (9,52)	
2,5 kW	CS-Z25UB4EAW	2,50	3,60	4 x 1,5	36/27/24 — 37/30/27		260 x 575 x 575 / 18		1/4 (6,35) / 3/8 (9,52)	
3,5 kW <sup>2)</sup>	CS-Z35UB4EAW	3,50	4,50	4 x 1,5	36/28/25 — 37/30/27		260 x 575 x 575 / 18		1/4 (6,35) / 3/8 (9,52)	
5,0 kW <sup>5)</sup>	CS-Z50UB4EAW	5,00	6,80	4 x 1,5	39/30/27 — 40/31/28		260 x 575 x 575 / 18		1/4 (6,35) / 1/2 (12,70)	
6,0 kW	CS-Z60UB4EAW	6,00	8,50	4 x 1,5	44/34/31 — 45/34/31		260 x 575 x 575 / 18		1/4 (6,35) / 1/2 (12,70)	



**CZ-RL511D**  
Optional  
wireless kit.

INTERNET CONTROL and BMS CONNECTIVITY: Optional.



Low Static Pressure Hide Away	Indoor unit	Cooling capacity	Heating capacity	Connection in. / out.	Sound pressure <sup>7)</sup>		Dimension / Net weight		Piping connections	
					Cool — Heat (Hi/Lo/S-Lo)		HxWxD		Liquid / Gas pipe	
					dB(A)		mm / kg		Inch (mm)	
2,0 kW	CS-MZ20UD3EA	2,00	3,20	4 x 1,5	34/29/26 — 36/29/26		200 x 750 x 640 / 19		1/4 (6,35) / 3/8 (9,52)	
2,5 kW	CS-Z25UD3EAW	2,50	3,60	4 x 1,5	35/29/26 — 37/29/26		200 x 750 x 640 / 19		1/4 (6,35) / 3/8 (9,52)	
3,5 kW <sup>2)</sup>	CS-Z35UD3EAW	3,50	4,50	4 x 1,5	35/29/26 — 37/29/26		200 x 750 x 640 / 19		1/4 (6,35) / 3/8 (9,52)	
5,0 kW <sup>5)</sup>	CS-Z50UD3EAW	5,00	6,80	4 x 1,5	41/31/28 — 41/32/29		200 x 750 x 640 / 19		1/4 (6,35) / 1/2 (12,70)	
6,0 kW	CS-Z60UD3EAW	6,00	8,50	4 x 1,5	43/32/29 — 43/34/31		200 x 750 x 640 / 19		1/4 (6,35) / 1/2 (12,70)	

1) The sound pressure of the indoor unit shows the value measured of a position of 1 m in front of the main body and 0,8 m below the unit. The sound pressure is measured in accordance with JIS C 9612. Q-Lo: Quiet mode. Lo: The lowest set fan speed. 2) The heating capacity is 4,2 kW connected to a CU-Z235TBE. 3) Compatible only with 2 ports R32 outdoor CU-Z235TBE / CU-Z241TBE / CU-Z250TBE. Minimum quantity of connection: 2 indoor units. Floor console indoor unit is compatible with R410A outdoors with 3, 4 or 5 ports: CU-3E18PBE, CU-3E23SBE, CU-4E23PBE, CU-4E27PBE and CU-5E34PBE. 4) The sound pressure of the units shows the value measured of a position 1 m in front of the main body and 1 m above floor. The sound pressure is measured in accordance with JIS C 9612. Q-Lo: Quiet mode. Lo: The lowest set fan speed. 5) The heating capacity is 5,3 kW connected to a CU-Z250TBE. 6) The sound pressure of the indoor unit shows the value measured of a position of 1,5 m below the unit. The sound pressure is measured in accordance with JIS C 9612. Q-Lo: Quiet mode. Lo: The lowest set fan speed. 7) The sound pressure of the indoor unit shows the value measured of a position of 1,5 m below the unit with 1 m duct on the suction side and 2 m duct on the discharge side. The sound pressure is measured in accordance with JIS C 9612. \* Tentative data.

## Free Multi R32 combinations table

### Free Multi 2x1 CU-2Z35TBE. Minimum capacity connected: 3,2 kW. Maximum capacity connected: 6,0 kW • R32 refrigerant

Indoor unit capacity	Cooling capacity (kW). Rooms			EER	SEER <sup>1)</sup>	Input power rating	A.E.C.	Current	Heating capacity (kW). Rooms			COP	SCOP <sup>1)</sup>	Input power rating	A.E.C.	Current
	A	B	Total (Min - Max)						W/W	kW	kWh					
<b>1 Room</b>																
16	1,60		1,60(1,10 - 2,30)	3,90		0,41(0,22 - 0,60)	205	1,95	2,60		2,60(0,70 - 3,80)	3,77		0,69(0,17 - 1,11)	345	3,20
20	2,00		2,00(1,10 - 2,90)	3,85		0,52(0,22 - 0,77)	260	2,45	3,20		3,20(0,70 - 4,80)	3,76		0,85(0,17 - 1,41)	425	3,95
25	2,50		2,50(1,10 - 3,50)	3,73		0,67(0,22 - 1,00)	335	3,15	3,60		3,60(0,70 - 5,50)	3,50		1,03(0,17 - 1,70)	515	4,75
35	3,50		3,50(1,10 - 4,00)	3,47		1,01(0,22 - 1,22)	505	4,70	4,20		4,20(0,70 - 5,60)	3,44		1,22(0,17 - 1,68)	610	5,65
<b>2 Rooms</b>																
16+16	1,60	1,60	3,20(1,50 - 4,00)	4,92	<b>8,50 A+++</b>	0,65(0,25 - 1,00)	325	3,05	2,10	2,10	4,20(1,10 - 5,60)	4,88	<b>4,60 A++</b>	0,86(0,21 - 1,34)	430	4,00
16+20	1,55	1,95	3,50(1,50 - 4,50)	4,86	<b>8,50 A+++</b>	0,72(0,25 - 1,10)	360	3,35	1,85	2,35	4,20(1,10 - 5,60)	4,88	<b>4,60 A++</b>	0,86(0,21 - 1,34)	430	4,00
16+25	1,35	2,15	3,50(1,50 - 4,50)	4,86	<b>8,50 A+++</b>	0,72(0,25 - 1,10)	360	3,35	1,65	2,55	4,20(1,10 - 5,60)	4,88	<b>4,60 A++</b>	0,86(0,21 - 1,34)	430	4,00
16+35	1,10	2,40	3,50(1,50 - 4,50)	4,86	<b>8,50 A+++</b>	0,72(0,25 - 1,10)	360	3,35	1,30	2,90	4,20(1,10 - 5,60)	4,88	<b>4,60 A++</b>	0,86(0,21 - 1,34)	430	4,00
20+20	1,75	1,75	3,50(1,50 - 4,50)	4,86	<b>8,50 A+++</b>	0,72(0,25 - 1,10)	360	3,35	2,10	2,10	4,20(1,10 - 5,60)	4,88	<b>4,60 A++</b>	0,86(0,21 - 1,34)	430	4,00
20+25	1,55	1,95	3,50(1,50 - 4,50)	4,86	<b>8,50 A+++</b>	0,72(0,25 - 1,10)	360	3,35	1,85	2,35	4,20(1,10 - 5,60)	4,88	<b>4,60 A++</b>	0,86(0,21 - 1,34)	430	4,00
20+35	1,25	2,25	3,50(1,50 - 4,50)	5,07	<b>8,50 A+++</b>	0,69(0,25 - 1,05)	345	3,25	1,55	2,65	4,20(1,10 - 5,60)	5,00	<b>4,60 A++</b>	0,84(0,21 - 1,29)	420	3,90
25+25	1,75	1,75	3,50(1,50 - 4,50)	5,07	<b>8,50 A+++</b>	0,69(0,25 - 1,05)	345	3,25	2,10	2,10	4,20(1,10 - 5,60)	5,00	<b>4,60 A++</b>	0,84(0,21 - 1,29)	420	3,90
25+35	1,45	2,05	3,50(1,50 - 4,50)	5,07	<b>8,50 A+++</b>	0,69(0,25 - 1,05)	345	3,25	1,75	2,45	4,20(1,10 - 5,60)	5,00	<b>4,60 A++</b>	0,84(0,21 - 1,29)	420	3,90

### Free Multi 2x1 CU-2Z41TBE. Minimum capacity connected: 3,2 kW. Maximum capacity connected: 6,0 kW • R32 refrigerant

Indoor unit capacity	Cooling capacity (kW). Rooms			EER	SEER <sup>1)</sup>	Input power rating	A.E.C.	Current	Heating capacity (kW). Rooms			COP	SCOP <sup>1)</sup>	Input power rating	A.E.C.	Current
	A	B	Total (Min - Max)						W/W	kW	kWh					
<b>1 Room</b>																
16	1,60		1,60(1,10 - 2,30)	3,90		0,41(0,22 - 0,60)	205	1,95	2,60		2,60(0,70 - 3,80)	3,77		0,69(0,17 - 1,11)	345	3,20
20	2,00		2,00(1,10 - 2,90)	3,85		0,52(0,22 - 0,77)	260	2,45	3,20		3,20(0,70 - 4,80)	3,76		0,85(0,17 - 1,41)	425	3,95
25	2,50		2,50(1,10 - 3,50)	3,73		0,67(0,22 - 1,00)	335	3,15	3,60		3,60(0,70 - 5,50)	3,50		1,03(0,17 - 1,70)	515	4,75
35	3,50		3,50(1,10 - 4,00)	3,47		1,01(0,22 - 1,22)	505	4,70	4,50		4,50(0,70 - 6,20)	3,60		1,25(0,17 - 1,81)	625	5,80
<b>2 Rooms</b>																
16+16	1,60	1,60	3,20(1,50 - 4,00)	4,71	<b>8,50 A+++</b>	0,68(0,25 - 0,99)	340	3,15	2,20	2,20	4,40(1,10 - 7,00)	4,68	<b>4,60 A++</b>	0,94(0,21 - 1,81)	470	4,35
16+20	1,60	2,00	3,60(1,50 - 4,50)	4,62	<b>8,50 A+++</b>	0,78(0,25 - 1,15)	390	3,60	2,05	2,55	4,60(1,10 - 7,00)	4,79	<b>4,60 A++</b>	0,96(0,21 - 1,79)	480	4,45
16+25	1,60	2,50	4,10(1,50 - 5,20)	4,56	<b>8,50 A+++</b>	0,90(0,25 - 1,37)	450	4,15	1,80	2,80	4,60(1,10 - 7,00)	4,79	<b>4,60 A++</b>	0,96(0,21 - 1,79)	480	4,45
16+35	1,30	2,80	4,10(1,50 - 5,20)	4,56	<b>8,50 A+++</b>	0,90(0,25 - 1,37)	450	4,15	1,45	3,15	4,60(1,10 - 7,00)	4,79	<b>4,60 A++</b>	0,96(0,21 - 1,79)	480	4,45
20+20	2,00	2,00	4,00(1,50 - 5,00)	4,49	<b>8,50 A+++</b>	0,89(0,25 - 1,31)	445	4,10	2,30	2,30	4,60(1,10 - 7,00)	4,84	<b>4,60 A++</b>	0,95(0,21 - 1,77)	475	4,40
20+25	1,80	2,30	4,10(1,50 - 5,20)	4,56	<b>8,50 A+++</b>	0,90(0,25 - 1,37)	450	4,15	2,05	2,55	4,60(1,10 - 7,00)	4,84	<b>4,60 A++</b>	0,95(0,21 - 1,77)	475	4,40
20+35	1,50	2,60	4,10(1,50 - 5,20)	4,56	<b>8,50 A+++</b>	0,90(0,25 - 1,37)	450	4,15	1,65	2,95	4,60(1,10 - 7,00)	4,84	<b>4,60 A++</b>	0,95(0,21 - 1,77)	475	4,40
25+25	2,05	2,05	4,10(1,50 - 5,20)	4,56	<b>8,50 A+++</b>	0,90(0,25 - 1,37)	450	4,15	2,30	2,30	4,60(1,10 - 7,00)	4,84	<b>4,60 A++</b>	0,95(0,21 - 1,77)	475	4,40
25+35	1,70	2,40	4,10(1,50 - 5,20)	4,56	<b>8,50 A+++</b>	0,90(0,25 - 1,37)	450	4,15	1,90	2,70	4,60(1,10 - 7,00)	4,84	<b>4,60 A++</b>	0,95(0,21 - 1,77)	475	4,40

### Free Multi 2x1 CU-2Z50TBE. Minimum capacity connected: 3,2 kW. Maximum capacity connected: 7,7 kW • R32 refrigerant

Indoor unit capacity	Cooling capacity (kW). Rooms			EER	SEER <sup>1)</sup>	Input power rating	A.E.C.	Current	Heating capacity (kW). Rooms			COP	SCOP <sup>1)</sup>	Input power rating	A.E.C.	Current
	A	B	Total (Min - Max)						W/W	kW	kWh					
<b>1 Room</b>																
16	1,60		1,60(1,10 - 2,30)	3,90		0,41(0,22 - 0,60)	205	1,95	2,60		2,60(0,70 - 3,80)	3,77		0,69(0,17 - 1,11)	345	3,20
20	2,00		2,00(1,10 - 2,90)	3,85		0,52(0,22 - 0,77)	260	2,45	3,20		3,20(0,70 - 4,80)	3,76		0,85(0,17 - 1,41)	425	3,95
25	2,50		2,50(1,10 - 3,50)	3,73		0,67(0,22 - 1,00)	335	3,15	3,60		3,60(0,70 - 5,50)	3,50		1,03(0,17 - 1,70)	515	4,75
35	3,50		3,50(1,10 - 4,00)	3,47		1,01(0,22 - 1,22)	505	4,70	4,50		4,50(0,70 - 6,20)	3,60		1,25(0,17 - 1,81)	625	5,80
42	4,20		4,20(1,10 - 4,50)	3,09		1,36(0,22 - 1,50)	680	6,35	5,00		5,00(1,10 - 6,40)	3,23		1,55(0,21 - 2,18)	775	7,15
50	5,00		5,00(1,20 - 5,10)	2,96		1,69(0,23 - 1,79)	845	7,80	5,30		5,30(1,10 - 6,80)	3,23		1,64(0,21 - 2,29)	820	7,60
<b>2 Rooms</b>																
16+16	1,60	1,60	3,20(1,50 - 4,00)	4,71	<b>8,50 A+++</b>	0,68(0,25 - 0,99)	340	3,15	2,60	2,60	5,20(1,10 - 7,00)	4,60	<b>4,60 A++</b>	1,13(0,21 - 1,81)	565	5,10
16+20	1,60	2,00	3,60(1,50 - 4,50)	4,62	<b>8,50 A+++</b>	0,78(0,25 - 1,15)	390	3,60	2,40	3,00	5,40(1,10 - 7,00)	4,58	<b>4,60 A++</b>	1,18(0,21 - 1,79)	590	5,35
16+25	1,60	2,50	4,10(1,50 - 5,20)	4,56	<b>8,50 A+++</b>	0,90(0,25 - 1,37)	450	4,15	2,10	3,30	5,40(1,10 - 7,00)	4,58	<b>4,60 A++</b>	1,18(0,21 - 1,79)	590	5,35
16+35	1,55	3,45	5,00(1,50 - 5,20)	4,24	<b>8,50 A+++</b>	1,18(0,25 - 1,37)	590	5,35	1,70	3,70	5,40(1,10 - 7,00)	4,58	<b>4,60 A++</b>	1,18(0,21 - 1,79)	590	5,35
16+42	1,40	3,60	5,00(1,50 - 5,40)	4,24	<b>8,50 A+++</b>	1,18(0,25 - 1,49)	590	5,35	1,55	4,05	5,60(1,10 - 7,20)	4,63	<b>4,60 A++</b>	1,21(0,21 - 1,80)	605	5,50
16+50	1,20	3,80	5,00(1,50 - 5,40)	4,24	<b>8,50 A+++</b>	1,18(0,25 - 1,49)	590	5,35	1,35	4,25	5,60(1,10 - 7,20)	4,63	<b>4,60 A++</b>	1,21(0,21 - 1,80)	605	5,50
20+20	2,00	2,00	4,00(1,50 - 5,00)	4,49	<b>8,50 A+++</b>	0,89(0,25 - 1,31)	445	4,10	2,70	2,70	5,40(1,10 - 7,00)	4,62	<b>4,60 A++</b>	1,17(0,21 - 1,77)	585	5,30
20+25	2,00	2,50	4,50(1,50 - 5,20)	4,37	<b>8,50 A+++</b>	1,03(0,25 - 1,37)	515	4,65	2,40	3,00	5,40(1,10 - 7,00)	4,62	<b>4,60 A++</b>	1,17(0,21 - 1,77)	585	5,30
20+35	1,80	3,20	5,00(1,50 - 5,40)	4,24	<b>8,50 A+++</b>	1,18(0,25 - 1,49)	590	5,35	2,05	3,55	5,60(1,10 - 7,20)	4,63	<b>4,60 A++</b>	1,21(0,21 - 1,80)	605	5,50
20+42	1,60	3,40	5,00(1,50 - 5,40)	4,24	<b>8,50 A+++</b>	1,18(0,25 - 1,49)	590	5,35	1,80	3,80	5,60(1,10 - 7,20)	4,63	<b>4,60 A++</b>	1,21(0,21 - 1,80)	605	5,50
20+50	1,45	3,55	5,00(1,50 - 5,40)	4,24	<b>8,50 A+++</b>	1,18(0,25 - 1,49)	590	5,35	1,60	4,00	5,60(1,10 - 7,20)	4,63	<b>4,60 A++</b>	1,21(0,21 - 1,80)	605	5,50
25+25	2,50	2,50	5,00(1,50 - 5,40)	4,24	<b>8,50 A+++</b>	1,18(0,25 - 1,49)	590	5,35	2,80	2,80	5,60(1,10 - 7,20)	4,63	<b>4,60 A++</b>	1,21(0,21 - 1,80)	605	5,50
25+35	2,10	2,90	5,00(1,50 - 5,40)	4,24	<b>8,50 A+++</b>	1,18(0,25 - 1,49)	590	5,35	2,35	3,25	5,60(1,10 - 7,20)	4,63	<b>4,60 A++</b>	1,21(0,21 - 1,80)	605	5,50
25+42	1,85	3,15	5,00(1,50 - 5,40)	4,24	<b>8,50 A+++</b>	1,18(0,25 - 1,49)	590	5,35	2,10	3,50	5,60(1,10 - 7,20)	4,63	<b>4,60 A++</b>	1,21(0,21 - 1,80)	605	5,50
25+50	1,65	3,35	5,00(1,50 - 5,40)	4,24	<b>8,50 A+++</b>	1,18(0,25 - 1,49)	590	5,35	1,85	3,75	5,60(1,10 - 7,20)	4,63	<b>4,60 A++</b>	1,21(0,21 - 1,80)	605	5,50
35+35	2,50	2,50	5,00(1,50 - 5,40)	4,24	<b>8,50 A+++</b>	1,18(0,25 - 1,49)	590	5,35	2,80	2,80	5,60(1,10 - 7,20)	4,63	<b>4,60 A++</b>	1,21(0,21 - 1,80)	605	5,50
35+42	2,25	2,75	5,00(1,50 - 5,40)	4,24	<b>8,50 A+++</b>	1,18(0,25 - 1,49)	590	5,35	2,55	3,05	5,60(1,10 - 7,20)	4,63	<b>4,60 A++</b>	1,21(0,21 - 1,80)	6	



## Free Multi 3x1 CU-3Z52TBE. Minimum capacity connected: 4,5 kW. Maximum capacity connected: 9,5 kW • R32 refrigerant

Indoor unit capacity	Cooling capacity (kW). Rooms				EER	SEER <sup>1)</sup>	Input power rating			A.E.C.	Current	Heating capacity (kW). Rooms				COP	SCOP <sup>1)</sup>	Input power rating			A.E.C.	Current	
	A	B	C	Total (Min-Max)			W/W	kW				kWh	230V	A	B			C	Total (Min-Max)	W/W			kW
<b>1 Room</b>																							
16	1,60			1,60(1,30-2,30)	4,00		0,40(0,25-0,64)	200	2,00	2,60	2,00	2,60	2,60(1,20-3,20)	4,33		0,60(0,30-0,96)	300	3,00					
20	2,00			2,00(1,80-2,90)	4,00		0,50(0,34-0,81)	250	2,50	3,20		3,20(1,20-4,10)	4,32		0,74(0,30-1,23)	370	3,70						
25	2,50			2,50(1,80-2,90)	3,97		0,63(0,34-0,81)	315	3,00	3,60		3,60(1,20-4,30)	3,83		0,94(0,30-1,23)	470	4,50						
35	3,50			3,50(1,80-3,80)	3,72		0,94(0,34-1,36)	470	4,30	4,50		4,50(1,20-5,80)	3,66		1,23(0,30-2,10)	615	5,80						
42	4,20			4,20(1,80-4,30)	3,07		1,37(0,34-1,99)	685	6,10	5,60		5,60(1,20-6,80)	3,26		1,72(0,30-2,93)	860	7,70						
50	5,00			5,00(1,90-5,70)	3,23		1,55(0,34-2,13)	775	6,80	6,80		6,80(1,20-6,90)	3,24		2,10(0,30-2,52)	1050	9,20						
<b>2 Rooms</b>																							
16+16	1,60	1,60		3,20(1,80-6,20)	5,42	<b>7,00 A++</b>	0,59(0,33-2,09)	295	2,90	2,60	2,60	2,60	5,20(1,40-7,00)	4,13	<b>3,80 A</b>	1,26(0,34-1,99)	630	5,80					
16+20	1,60	2,00		3,60(1,80-6,20)	4,93	<b>7,00 A++</b>	0,73(0,33-2,05)	365	3,50	2,58	3,22	2,58	5,80(1,40-7,00)	4,03	<b>3,80 A</b>	1,44(0,33-1,95)	720	6,60					
16+25	1,60	2,50		4,10(1,80-6,20)	4,66	<b>7,00 A++</b>	0,88(0,33-2,05)	440	4,10	2,42	3,78	2,42	6,20(1,40-7,00)	3,95	<b>3,80 A</b>	1,57(0,33-1,95)	785	7,20					
16+35	1,60	3,50		5,10(1,80-6,30)	3,89	<b>7,00 A++</b>	1,31(0,33-2,06)	655	6,00	2,13	4,67	2,13	6,80(1,40-7,30)	3,89	<b>3,80 A</b>	1,75(0,29-2,05)	875	7,90					
16+42	1,43	3,77		5,20(1,90-6,40)	3,85	<b>7,00 A++</b>	1,35(0,35-2,10)	675	6,20	1,88	4,92	1,88	6,80(1,40-7,30)	3,98	<b>3,80 A</b>	1,71(0,31-2,04)	855	7,80					
16+50	1,26	3,94		5,20(1,90-6,80)	4,44	<b>7,20 A++</b>	1,17(0,34-2,04)	585	5,40	1,65	5,15	1,65	6,80(1,40-8,00)	4,36	<b>4,00 A+</b>	1,56(0,27-2,15)	780	7,10					
20+20	2,00	2,00		4,00(1,80-6,20)	4,71	<b>7,00 A++</b>	0,85(0,33-2,01)	425	4,00	3,20	3,20	3,20	6,40(1,40-7,00)	3,93	<b>3,80 A</b>	1,63(0,32-1,95)	815	7,40					
20+25	2,00	2,50		4,50(1,80-6,20)	4,33	<b>7,00 A++</b>	1,04(0,33-2,01)	520	4,80	3,02	3,78	3,02	6,80(1,40-7,00)	3,86	<b>3,80 A</b>	1,76(0,29-1,95)	880	8,00					
20+35	1,89	3,31		5,20(1,80-6,30)	3,85	<b>7,00 A++</b>	1,35(0,33-2,02)	675	6,20	2,47	4,33	2,47	6,80(1,40-7,30)	3,98	<b>3,80 A</b>	1,71(0,28-2,04)	855	7,80					
20+42	1,68	3,52		5,20(1,90-6,40)	3,94	<b>7,00 A++</b>	1,32(0,35-2,06)	660	6,00	2,19	4,61	2,19	6,80(1,40-7,30)	4,00	<b>3,80 A</b>	1,70(0,30-2,00)	850	7,80					
20+50	1,49	3,71		5,20(1,90-6,80)	4,44	<b>7,20 A++</b>	1,17(0,34-2,04)	585	5,40	1,94	4,86	1,94	6,80(1,40-8,00)	4,36	<b>4,00 A+</b>	1,56(0,27-2,15)	780	7,10					
25+25	2,50	2,50		5,00(1,80-6,20)	3,91	<b>7,00 A++</b>	1,28(0,33-2,01)	640	5,80	3,40	3,40	3,40	6,80(1,40-7,00)	3,86	<b>3,80 A</b>	1,76(0,29-1,95)	880	8,00					
25+35	2,17	3,03		5,20(1,90-6,30)	3,85	<b>7,00 A++</b>	1,35(0,35-2,02)	675	6,20	2,83	3,97	2,83	6,80(1,40-7,30)	3,98	<b>3,80 A</b>	1,71(0,28-2,04)	855	7,80					
25+42	1,94	3,26		5,20(1,90-6,40)	3,94	<b>7,00 A++</b>	1,32(0,35-2,06)	660	6,00	2,54	4,26	2,54	6,80(1,40-7,30)	4,00	<b>3,80 A</b>	1,70(0,28-2,00)	850	7,80					
25+50	1,73	3,47		5,20(1,90-6,80)	4,44	<b>7,20 A++</b>	1,17(0,34-2,04)	585	5,40	2,27	4,53	2,27	6,80(1,40-8,00)	4,36	<b>4,00 A+</b>	1,56(0,24-2,15)	780	7,10					
35+35	2,60	2,60		5,20(1,90-6,40)	4,06	<b>7,00 A++</b>	1,28(0,35-2,02)	640	5,80	3,40	3,40	3,40	6,80(1,40-7,50)	4,02	<b>3,80 A</b>	1,69(0,27-2,06)	845	7,70					
35+42	2,36	2,84		5,20(1,90-6,50)	4,06	<b>7,00 A++</b>	1,28(0,35-2,07)	640	5,80	3,09	3,71	3,09	6,80(1,40-7,50)	4,02	<b>3,80 A</b>	1,69(0,26-2,06)	845	7,70					
35+50	2,14	3,06		5,20(1,90-6,90)	4,60	<b>7,20 A++</b>	1,13(0,36-2,04)	565	5,20	2,80	4,00	2,80	6,80(1,40-8,00)	4,42	<b>4,00 A+</b>	1,54(0,24-2,08)	770	7,00					
42+42	2,60	2,60		5,20(1,90-6,50)	4,06	<b>7,00 A++</b>	1,28(0,35-2,07)	640	5,80	3,40	3,40	3,40	6,80(1,40-7,60)	4,12	<b>3,80 A</b>	1,65(0,26-2,09)	825	7,50					
42+50	2,37	2,83		5,20(1,90-6,90)	4,60	<b>7,20 A++</b>	1,13(0,36-2,04)	565	5,20	3,10	3,70	3,10	6,80(1,40-8,00)	4,44	<b>4,00 A+</b>	1,53(0,24-2,08)	765	7,00					
<b>3 Rooms</b>																							
16+16+16	1,60	1,60	1,60	4,80(1,80-7,20)	5,05	<b>8,50 A+++</b>	0,95(0,36-2,13)	475	4,40	2,26	2,26	2,26	6,78(1,50-8,10)	4,58	<b>4,20 A+</b>	1,48(0,29-2,10)	740	6,80					
16+16+20	1,60	1,60	2,00	5,20(1,80-7,30)	4,77	<b>8,50 A+++</b>	1,09(0,36-2,18)	545	5,00	2,09	2,09	2,62	6,80(1,60-8,30)	4,63	<b>4,20 A+</b>	1,47(0,32-2,17)	735	6,70					
16+16+25	1,46	1,46	2,28	5,20(1,90-7,20)	4,77	<b>8,50 A+++</b>	1,09(0,39-2,09)	545	5,00	1,91	1,91	2,98	6,80(1,60-8,30)	4,63	<b>4,20 A+</b>	1,47(0,32-2,17)	735	6,70					
16+16+35	1,24	1,24	2,72	5,20(1,90-7,20)	4,77	<b>8,50 A+++</b>	1,09(0,39-2,04)	545	5,00	1,62	1,62	3,56	6,80(1,60-8,30)	4,69	<b>4,20 A+</b>	1,45(0,34-2,10)	725	6,60					
16+16+42	1,12	1,12	2,96	5,20(1,80-7,30)	4,77	<b>8,50 A+++</b>	1,09(0,39-2,09)	545	5,00	1,47	1,47	3,86	6,80(1,60-8,30)	4,69	<b>4,20 A+</b>	1,45(0,31-2,10)	725	6,60					
16+16+50	1,01	1,01	3,18	5,20(1,80-7,30)	5,15	<b>8,50 A+++</b>	1,01(0,42-1,91)	505	4,70	1,33	1,33	4,14	6,80(1,60-8,30)	5,07	<b>4,20 A+</b>	1,34(0,33-1,96)	670	6,10					
16+20+20	1,48	1,86	1,86	5,20(1,90-7,20)	4,77	<b>8,50 A+++</b>	1,09(0,39-2,09)	545	5,00	1,94	2,43	2,43	6,80(1,60-8,30)	4,66	<b>4,20 A+</b>	1,46(0,31-2,12)	730	6,70					
16+20+25	1,36	1,70	2,14	5,20(1,90-7,20)	4,77	<b>8,50 A+++</b>	1,09(0,39-2,09)	545	5,00	1,78	2,23	2,79	6,80(1,60-8,30)	4,66	<b>4,20 A+</b>	1,46(0,31-2,12)	730	6,70					
16+20+35	1,17	1,46	2,57	5,20(1,90-7,20)	4,77	<b>8,50 A+++</b>	1,09(0,39-2,00)	545	5,00	1,53	1,92	3,35	6,80(1,60-8,30)	4,69	<b>4,20 A+</b>	1,45(0,34-2,10)	725	6,60					
16+20+42	1,07	1,33	2,80	5,20(1,80-7,30)	4,77	<b>8,50 A+++</b>	1,09(0,39-2,09)	545	5,00	1,39	1,74	3,67	6,80(1,60-8,30)	4,72	<b>4,20 A+</b>	1,44(0,31-2,09)	720	6,60					
16+20+50	0,97	1,21	3,02	5,20(1,80-7,30)	5,15	<b>8,50 A+++</b>	1,01(0,42-1,86)	505	4,70	1,27	1,58	3,95	6,80(1,60-8,30)	5,11	<b>4,20 A+</b>	1,33(0,34-1,95)	665	6,10					
16+25+25	1,26	1,97	1,97	5,20(1,90-7,20)	4,77	<b>8,50 A+++</b>	1,09(0,39-2,09)	545	5,00	1,64	2,58	2,58	6,80(1,60-8,30)	4,66	<b>4,20 A+</b>	1,46(0,31-2,12)	730	6,70					
16+25+35	1,09	1,71	2,40	5,20(1,80-7,30)	4,77	<b>8,50 A+++</b>	1,09(0,39-2,09)	545	5,00	1,43	2,24	3,13	6,80(1,60-8,30)	4,69	<b>4,20 A+</b>	1,45(0,34-2,10)	725	6,60					
16+25+42	1,00	1,57	2,63	5,20(1,80-7,30)	4,77	<b>8,50 A+++</b>	1,09(0,39-2,09)	545	5,00	1,31	2,05	3,44	6,80(1,60-8,30)	4,72	<b>4,20 A+</b>	1,44(0,31-2,09)	720	6,60					
16+25+50	0,91	1,43	2,86	5,20(1,80-7,30)	5,15	<b>8,50 A+++</b>	1,01(0,42-1,86)	505	4,70	1,19	1,87	3,74	6,80(1,60-8,30)	5,11	<b>4,20 A+</b>	1,33(0,34-1,95)	665	6,10					
16+35+35	0,96	2,12	2,12	5,20(1,80-7,30)	4,95	<b>8,50 A+++</b>	1,05(0,39-2,04)	525	4,80	1,26	2,77	2,77	6,80(1,60-8,30)	4,76	<b>4,20 A+</b>	1,43(0,32-2,07)	715	6,50					
16+35+42	0,89	1,96	2,35	5,20(1,80-7,30)	4,95	<b>8,50 A+++</b>	1,05(0,39-2,04)	525	4,80	1,17	2,56	3,07	6,80(1,60-8,30)	4,79	<b>4,20 A+</b>	1,42(0,32-2,06)	710	6,50					
20+20+20	1,73	1,73	1,73	5,19(1,90-7,20)	4,76	<b>8,50 A+++</b>	1,09(0,39-2,04)	545	5,00	2,26	2,26	2,26	6,78(1,60-8,30)	4,64	<b>4,20 A+</b>	1,46(0,31-2,11)	730	6,70					
20+20+25	1,60	1,60	2,00	5,20(1,90-7,20)	4,77	<b>8,50 A+++</b>	1,09(0,39-2,04)	545	5,00	2,09	2,09												

## Free Multi R32 combinations table

## Free Multi 3x1 CU-3Z68TBE. Minimum capacity connected: 4,5 kW. Maximum capacity connected: 11,2 kW • R32 refrigerant

Indoor unit capacity	Cooling capacity (kW). Rooms				EER	SEER <sup>1)</sup>	Input power rating			Heating capacity (kW). Rooms				COP	SCOP <sup>1)</sup>	Input power rating			A.E.C.	Current
	A	B	C	Total (Min - Max)			W/W	kW	kWh	230V	A	B	C			Total (Min - Max)	W/W	kW		
<b>1 Room</b>																				
16	1,60			1,60(1,30-2,30)	4,00		0,40(0,25-0,64)	200	2,00	2,60			2,60(1,20-3,20)	4,33		0,60(0,30-0,96)	300	3,00		
20	2,00			2,00(1,80-2,90)	4,00		0,50(0,34-0,81)	250	2,50	3,20			3,20(1,20-4,10)	4,32		0,74(0,30-1,23)	370	3,70		
25	2,50			2,50(1,80-2,90)	3,97		0,63(0,34-0,81)	315	3,20	3,60			3,60(1,20-4,30)	3,83		0,94(0,30-1,23)	470	4,70		
35	3,50			3,50(1,80-3,80)	3,72		0,94(0,34-1,36)	470	4,50	4,50			4,50(1,20-5,80)	3,66		1,23(0,30-2,10)	615	6,00		
42	4,20			4,20(1,80-4,30)	3,07		1,37(0,34-1,99)	685	6,40	5,60			5,60(1,20-6,80)	3,26		1,72(0,30-2,93)	860	8,00		
50	5,00			5,00(1,90-5,70)	3,23		1,55(0,34-2,13)	775	7,20	6,80			6,80(1,20-6,90)	3,24		2,10(0,30-2,52)	1050	9,70		
60	6,00			6,00(1,90-6,20)	2,96		2,03(0,34-2,33)	1015	9,20	8,50			8,50(1,30-9,00)	3,54		2,40(0,62-2,55)	1200	11,10		
<b>2 Rooms</b>																				
16+16	1,60	1,60		3,20(1,90-6,40)	5,71	6,10 A++	0,56(0,27-2,12)	280	2,80	2,60	2,60		5,20(2,70-9,80)	4,00	3,80 A	1,30(0,66-3,01)	650	5,90		
16+20	1,60	2,00		3,60(1,90-6,40)	5,22	6,10 A++	0,69(0,27-2,08)	345	3,40	2,58	3,22		5,80(2,70-9,80)	3,92	3,80 A	1,48(0,65-3,02)	740	6,80		
16+25	1,60	2,50		4,10(1,90-6,40)	4,94	6,10 A++	0,83(0,27-2,08)	415	3,90	2,42	3,78		6,20(2,70-9,80)	3,85	3,80 A	1,61(0,65-3,02)	805	7,40		
16+35	1,60	3,50		5,10(1,90-6,90)	4,08	6,10 A++	1,25(0,27-2,48)	625	5,70	2,23	4,87		7,10(2,70-9,90)	3,74	3,80 A	1,90(0,63-3,02)	950	8,60		
16+42	1,60	4,20		5,80(1,90-6,90)	3,60	6,10 A++	1,61(0,27-2,44)	805	7,40	2,26	5,94		8,20(2,70-9,90)	3,52	3,80 A	2,33(0,63-3,02)	1165	10,50		
16+50	1,60	5,00		6,60(2,00-7,50)	3,63	6,50 A++	1,82(0,28-2,52)	910	8,20	2,06	6,44		8,50(2,80-10,20)	3,76	3,80 A	2,26(0,56-2,99)	1130	10,20		
16+60	1,43	5,37		6,80(2,00-7,50)	3,49	6,50 A++	1,95(0,28-2,52)	975	8,80	1,79	6,71		8,50(2,80-10,20)	3,76	3,80 A	2,26(0,56-2,99)	1130	10,20		
20+20	2,00	2,00		4,00(1,90-6,40)	5,00	6,10 A++	0,80(0,27-2,04)	400	3,80	3,20	3,20		6,40(2,70-9,80)	3,83	3,80 A	1,67(0,64-3,02)	835	7,60		
20+25	2,00	2,50		4,50(1,90-6,40)	4,59	6,10 A++	0,98(0,27-2,04)	490	4,60	3,02	3,78		6,80(2,70-9,80)	3,78	3,80 A	1,80(0,64-3,02)	900	8,10		
20+35	2,00	3,50		5,50(1,90-6,90)	3,85	6,10 A++	1,43(0,27-2,44)	715	6,50	2,80	4,90		7,70(2,70-9,90)	3,65	3,80 A	2,11(0,63-3,02)	1055	9,50		
20+42	2,00	4,20		6,20(1,90-6,90)	3,35	6,10 A++	1,85(0,27-2,40)	925	8,40	2,74	5,76		8,50(2,70-9,90)	3,48	3,80 A	2,44(0,62-3,03)	1220	11,00		
20+50	1,94	4,86		6,80(2,00-7,50)	3,49	6,50 A++	1,95(0,28-2,48)	975	8,80	2,43	6,07		8,50(2,80-10,20)	3,76	3,80 A	2,26(0,56-2,99)	1130	10,20		
20+60	1,70	5,10		6,80(2,00-7,50)	3,49	6,50 A++	1,95(0,28-2,48)	975	8,80	2,12	6,38		8,50(2,80-10,20)	3,76	3,80 A	2,26(0,56-2,99)	1130	10,20		
25+25	2,50	2,50		5,00(1,90-6,80)	4,13	6,10 A++	1,21(0,27-2,43)	605	5,60	3,60	3,60		7,20(2,70-9,80)	3,71	3,80 A	1,94(0,64-3,02)	970	8,80		
25+35	2,50	3,50		6,00(1,90-6,90)	3,47	6,10 A++	1,73(0,27-2,44)	865	7,90	3,37	4,73		8,10(2,70-9,90)	3,60	3,80 A	2,25(0,63-3,02)	1125	10,20		
25+42	2,50	4,20		6,70(1,90-6,90)	2,94	6,10 A++	2,28(0,27-2,40)	1140	10,30	3,17	5,33		8,50(2,70-9,90)	3,48	3,80 A	2,44(0,62-3,03)	1220	11,00		
25+50	2,27	4,53		6,80(1,90-7,50)	3,49	6,50 A++	1,95(0,26-2,48)	975	8,80	2,83	5,67		8,50(2,80-10,20)	3,76	3,80 A	2,26(0,56-2,99)	1130	10,20		
25+60	2,00	4,80		6,80(1,90-7,50)	3,49	6,50 A++	1,95(0,26-2,48)	975	8,80	2,50	6,00		8,50(2,80-10,20)	3,76	3,80 A	2,26(0,56-2,99)	1130	10,20		
35+35	3,40	3,40		6,80(1,90-7,00)	2,97	6,10 A++	2,29(0,27-2,40)	1145	10,40	4,25	4,25		8,50(2,80-10,00)	3,56	3,80 A	2,39(0,64-3,02)	1195	10,80		
35+42	3,09	3,71		6,80(1,90-7,10)	3,04	6,10 A++	2,24(0,27-2,50)	1120	10,10	3,86	4,64		8,50(2,80-10,00)	3,56	3,80 A	2,39(0,60-3,02)	1195	10,80		
35+50	2,80	4,00		6,80(2,00-7,60)	3,64	6,50 A++	1,87(0,28-2,48)	935	8,50	3,50	5,00		8,50(2,80-10,30)	3,86	3,80 A	2,20(0,54-2,97)	1100	10,00		
35+60	2,51	4,29		6,80(2,00-7,60)	3,64	6,50 A++	1,87(0,28-2,48)	935	8,50	3,13	5,37		8,50(2,80-10,30)	3,86	3,80 A	2,20(0,54-2,97)	1100	10,00		
42+42	3,40	3,40		6,80(1,90-7,10)	3,02	6,10 A++	2,25(0,26-2,45)	1125	10,20	4,25	4,25		8,50(2,80-10,00)	3,57	3,80 A	2,38(0,60-2,98)	1190	10,80		
42+50	3,10	3,70		6,80(2,00-7,60)	3,64	6,50 A++	1,87(0,28-2,44)	935	8,50	3,88	4,62		8,50(2,80-10,30)	3,88	3,80 A	2,19(0,54-2,96)	1095	9,90		
42+60	2,80	4,00		6,80(2,00-7,60)	3,64	6,50 A++	1,87(0,28-2,44)	935	8,50	3,50	5,00		8,50(2,80-10,30)	3,88	3,80 A	2,19(0,54-2,96)	1095	9,90		
50+50	3,40	3,40		6,80(2,10-8,10)	4,10	6,50 A++	1,66(0,32-2,50)	830	7,60	4,25	4,25		8,50(2,80-10,50)	4,15	3,80 A	2,05(0,51-2,87)	1025	9,30		
50+60	3,09	3,71		6,80(2,10-8,10)	4,10	6,50 A++	1,66(0,32-2,50)	830	7,60	3,86	4,64		8,50(2,80-10,50)	4,15	3,80 A	2,05(0,51-2,87)	1025	9,30		
<b>3 Rooms</b>																				
16+16+16	1,60	1,60	1,60	4,80(1,90-8,00)	4,85	8,00 A++	0,99(0,27-2,56)	495	4,60	2,60	2,60	2,60	7,80(3,30-10,40)	3,98	4,20 A+	1,96(0,64-2,95)	980	8,90		
16+16+20	1,60	1,60	2,00	5,20(1,90-8,00)	4,60	8,00 A++	1,13(0,27-2,46)	565	5,20	2,58	2,58	3,24	8,40(3,30-10,40)	3,84	4,20 A+	2,19(0,64-2,94)	1095	9,90		
16+16+25	1,60	1,60	2,50	5,70(1,90-8,00)	4,19	8,00 A++	1,36(0,27-2,46)	680	6,20	2,39	2,39	3,72	8,50(3,30-10,40)	3,81	4,20 A+	2,23(0,64-2,94)	1115	10,10		
16+16+35	1,60	1,60	3,50	6,70(1,90-8,00)	3,68	8,00 A++	1,82(0,27-2,37)	910	8,20	2,03	2,03	4,44	8,50(3,30-10,40)	3,94	4,20 A+	2,16(0,63-2,92)	1080	9,80		
16+16+42	1,47	1,47	3,86	6,80(1,90-8,10)	3,66	8,00 A++	1,86(0,27-2,46)	930	8,40	1,84	1,84	4,82	8,50(3,30-10,50)	3,95	4,20 A+	2,15(0,62-2,95)	1075	9,70		
16+16+50	1,33	1,33	4,14	6,80(2,00-8,50)	3,93	8,00 A++	1,73(0,32-2,42)	865	7,90	1,66	1,66	5,18	8,50(3,20-10,60)	4,21	4,20 A+	2,02(0,60-2,80)	1010	9,10		
16+16+60	1,18	1,18	4,44	6,80(2,00-8,50)	3,93	8,00 A++	1,73(0,32-2,42)	865	7,90	1,48	1,48	5,54	8,50(3,20-10,60)	4,21	4,20 A+	2,02(0,60-2,80)	1010	9,10		
16+20+20	1,60	2,00	2,00	5,60(1,90-8,00)	4,38	8,00 A++	1,28(0,27-2,46)	640	5,80	2,42	3,04	3,04	8,50(3,30-10,40)	3,83	4,20 A+	2,22(0,63-2,93)	1110	10,00		
16+20+25	1,60	2,00	2,50	6,10(1,90-8,00)	4,01	8,00 A++	1,52(0,27-2,46)	760	6,90	2,23	2,79	3,48	8,50(3,30-10,40)	3,83	4,20 A+	2,22(0,63-2,93)	1110	10,00		
16+20+35	1,53	1,92	3,35	6,80(1,90-8,00)	3,66	8,00 A++	1,86(0,27-2,37)	930	8,40	1,92	2,39	4,19	8,50(3,30-10,40)	3,95	4,20 A+	2,15(0,62-2,86)	1075	9,70		
16+20+42	1,39	1,74	3,67	6,80(1,90-8,10)	3,66	8,00 A++	1,86(0,27-2,42)	930	8,40	1,74	2,18	4,58	8,50(3,30-10,50)	3,95	4,20 A+	2,15(0,62-2,90)	1075	9,70		
16+20+50	1,27	1,58	3,95	6,80(2,00-8,50)	4,05	8,00 A++	1,68(0,32-2,42)	840	7,70	1,58	1,98	4,94	8,50(3,20-10,60)	4,23	4,20 A+	2,01(0,60-2,79)	1005	9,10		
16+20+60	1,13	1,42	4,25	6,80(2,00-8,50)	4,05	8,00 A++	1,68(0,32-2,42)	840	7,70	1,42	1,77	5,31	8,50(3,20-10,60)	4,23	4,20 A+	2,01(0,60-2,79)	1005	9,10		
16+25+25	1,60	2,50	2,50	6,60(1,90-8,00)	3,73	8,00 A++	1,77(0,27-2,46)	885	8,00	2,06	3,22	3,22	8,50(3,30-10,40)	3,83	4,20 A+	2,22(0,63-2,93)	1110	10,00		
16+25+35	1,43	2,24	3,13	6,80(1,90-8,00)	3,66	8,00 A++	1,86(0,27-2,37)	930	8,40	1,79	2,80	3,91	8,50(3,30-10,40)	3,95	4,20 A+	2,15(0,62-2,86)	1075	9,70		

## Free Multi 3x1 CU-3Z68TBE. Minimum capacity connected: 4,5 kW. Maximum capacity connected: 11,2 kW • R32 refrigerant

Indoor unit capacity	Cooling capacity (kW). Rooms				EER	SEER <sup>1)</sup>	Input power rating			A.E.C.	Current	Heating capacity (kW). Rooms				COP	SCOP <sup>1)</sup>	Input power rating			A.E.C.	Current
	A	B	C	Total (Min - Max)			W/W	kW	kWh			230V	A	B	C			Total (Min - Max)	W/W	kW		
25+25+35	2,00	2,00	2,80	6,80(1,90-8,00)	3,66	<b>8,00 A++</b>	1,86(0,27-2,32)	930	8,40	2,50	2,50	3,50	8,50(3,30-10,40)	3,95	<b>4,20 A+</b>	2,15(0,62-2,85)	1075	9,70				
25+25+42	1,85	1,85	3,10	6,80(1,90-8,10)	3,74	<b>8,00 A++</b>	1,82(0,29-2,42)	910	8,20	2,31	2,31	3,88	8,50(3,30-10,50)	3,97	<b>4,20 A+</b>	2,14(0,62-2,89)	1070	9,70				
25+25+50	1,70	1,70	3,40	6,80(2,00-8,50)	4,05	<b>8,00 A++</b>	1,68(0,34-2,38)	840	7,70	2,13	2,13	4,24	8,50(3,20-10,60)	4,25	<b>4,20 A+</b>	2,00(0,60-2,78)	1000	9,00				
25+25+60	1,55	1,55	3,70	6,80(2,00-8,50)	4,05	<b>8,00 A++</b>	1,68(0,34-2,38)	840	7,70	1,93	1,93	4,64	8,50(3,20-10,60)	4,25	<b>4,20 A+</b>	2,00(0,60-2,78)	1000	9,00				
25+35+35	1,78	2,51	2,51	6,80(1,90-8,10)	3,74	<b>8,00 A++</b>	1,82(0,29-2,33)	910	8,20	2,24	3,13	3,13	8,50(3,30-10,50)	4,01	<b>4,20 A+</b>	2,12(0,64-2,87)	1060	9,60				
25+35+42	1,67	2,33	2,80	6,80(1,90-8,20)	3,74	<b>8,00 A++</b>	1,82(0,29-2,42)	910	8,20	2,08	2,92	3,50	8,50(3,30-10,50)	4,03	<b>4,20 A+</b>	2,11(0,64-2,86)	1055	9,50				
25+35+50	1,55	2,16	3,09	6,80(2,00-8,50)	4,05	<b>8,00 A++</b>	1,68(0,34-2,33)	840	7,70	1,93	2,70	3,87	8,50(3,20-10,60)	4,29	<b>4,20 A+</b>	1,98(0,60-2,76)	990	9,00				
25+42+42	1,56	2,62	2,62	6,80(1,90-8,20)	3,84	<b>8,00 A++</b>	1,77(0,29-2,37)	885	8,00	1,94	3,28	3,28	8,50(3,30-10,50)	4,05	<b>4,20 A+</b>	2,10(0,63-2,86)	1050	9,50				
35+35+35	2,26	2,26	2,26	6,78(1,90-8,20)	3,83	<b>8,00 A++</b>	1,77(0,29-2,33)	885	8,00	2,83	2,83	2,83	8,49(3,30-10,50)	4,12	<b>4,20 A+</b>	2,06(0,63-2,85)	1030	9,30				
35+35+42	2,13	2,13	2,54	6,80(1,90-8,20)	3,84	<b>8,00 A++</b>	1,77(0,29-2,33)	885	8,00	2,66	2,66	3,18	8,50(3,30-10,50)	4,15	<b>4,20 A+</b>	2,05(0,63-2,80)	1025	9,30				

1) Energy Label Scale from A+++ to D.

## Free Multi 4x1 CU-4Z68TBE. Minimum capacity connected: 4,5 kW. Maximum capacity connected: 11,5 kW • R32 refrigerant

Indoor unit capacity	Cooling capacity (kW). Rooms					EER	SEER <sup>1)</sup>	Input power rating			A.E.C.	Current	Heating capacity (kW). Rooms					COP	SCOP <sup>1)</sup>	Input power rating			A.E.C.	Current		
	A	B	C	D	Total (Min - Max)			W/W	kW	kWh			230V	A	B	C	D			Total (Min - Max)	W/W	kW			kWh	230V
<b>1 Room</b>																										
16	1,60				1,60(1,30-2,30)	4,00		0,40(0,25-0,64)	200	2,00	2,60								2,60(1,20-3,20)	4,33			0,60(0,30-0,96)	300	3,00	
20	2,00				2,00(1,80-2,90)	4,00		0,50(0,34-0,81)	250	2,50	3,20								3,20(1,20-4,10)	4,32			0,74(0,30-1,23)	370	3,70	
25	2,50				2,50(1,80-2,90)	3,97		0,63(0,34-0,81)	315	3,20	3,60								3,60(1,20-4,30)	3,83			0,94(0,30-1,23)	470	4,70	
35	3,50				3,50(1,80-3,80)	3,72		0,94(0,34-1,36)	470	4,50	4,50								4,50(1,20-5,80)	3,66			1,23(0,30-2,10)	615	6,00	
42	4,20				4,20(1,80-4,30)	3,07		1,37(0,34-1,99)	685	6,40	5,60								5,60(1,20-6,80)	3,26			1,72(0,30-2,93)	860	8,00	
50	5,00				5,00(1,90-5,70)	3,23		1,55(0,34-2,13)	775	7,20	6,80								6,80(1,20-6,90)	3,24			2,10(0,30-2,52)	1050	9,70	
60	6,00				6,00(1,90-6,20)	2,96		2,03(0,34-2,33)	1015	9,20	8,50								8,50(1,30-9,00)	3,54			2,40(0,62-2,55)	1200	11,10	
<b>2 Rooms</b>																										
16+16	1,60	1,60			3,20(1,90-6,40)	5,71	<b>6,10 A++</b>	0,56(0,27-2,12)	280	2,80	2,60	2,60							5,20(2,70-9,80)	4,00	<b>3,80 A</b>	1,30(0,66-3,01)	650	5,90		
16+20	1,60	2,00			3,60(1,90-6,40)	5,22	<b>6,10 A++</b>	0,69(0,27-2,08)	345	3,40	2,58	3,22							5,80(2,70-9,80)	3,92	<b>3,80 A</b>	1,48(0,65-3,02)	740	6,80		
16+25	1,60	2,50			4,10(1,90-6,40)	4,94	<b>6,10 A++</b>	0,83(0,27-2,08)	415	3,90	2,42	3,78							6,20(2,70-9,80)	3,85	<b>3,80 A</b>	1,61(0,65-3,02)	805	7,40		
16+35	1,60	3,50			5,10(1,90-6,90)	4,08	<b>6,10 A++</b>	1,25(0,27-2,48)	625	5,70	2,23	4,87							7,10(2,70-9,90)	3,74	<b>3,80 A</b>	1,90(0,63-3,02)	950	8,60		
16+42	1,60	4,20			5,80(1,90-6,90)	3,60	<b>6,10 A++</b>	1,61(0,27-2,44)	805	7,40	2,26	5,94							8,20(2,70-9,90)	3,52	<b>3,80 A</b>	2,33(0,63-3,02)	1165	10,50		
16+50	1,60	5,00			6,60(2,00-7,50)	3,63	<b>6,50 A++</b>	1,82(0,28-2,52)	910	8,20	2,06	6,44							8,50(2,80-10,20)	3,76	<b>3,80 A</b>	2,26(0,56-2,99)	1130	10,20		
16+60	1,43	5,37			6,80(2,00-7,50)	3,49	<b>6,50 A++</b>	1,95(0,28-2,52)	975	8,80	1,79	6,71							8,50(2,80-10,20)	3,76	<b>3,80 A</b>	2,26(0,56-2,99)	1130	10,20		
20+20	2,00	2,00			4,00(1,90-6,40)	5,00	<b>6,10 A++</b>	0,80(0,27-2,04)	400	3,80	3,20	3,20							6,40(2,70-9,80)	3,83	<b>3,80 A</b>	1,67(0,64-3,02)	835	7,60		
20+25	2,00	2,50			4,50(1,90-6,40)	4,59	<b>6,10 A++</b>	0,98(0,27-2,04)	490	4,60	3,02	3,78							6,80(2,70-9,80)	3,78	<b>3,80 A</b>	1,80(0,64-3,02)	900	8,10		
20+35	2,00	3,50			5,50(1,90-6,90)	3,85	<b>6,10 A++</b>	1,43(0,27-2,44)	715	6,50	2,80	4,90							7,70(2,70-9,90)	3,65	<b>3,80 A</b>	2,11(0,63-3,02)	1055	9,50		
20+42	2,00	4,20			6,20(1,90-6,90)	3,35	<b>6,10 A++</b>	1,85(0,27-2,40)	925	8,40	2,74	5,76							8,50(2,70-9,90)	3,48	<b>3,80 A</b>	2,44(0,62-3,03)	1220	11,00		
20+50	1,94	4,86			6,80(2,00-7,50)	3,49	<b>6,50 A++</b>	1,95(0,28-2,48)	975	8,80	2,43	6,07							8,50(2,80-10,20)	3,76	<b>3,80 A</b>	2,26(0,56-2,99)	1130	10,20		
20+60	1,70	5,10			6,80(2,00-7,50)	3,49	<b>6,50 A++</b>	1,95(0,28-2,48)	975	8,80	2,12	6,38							8,50(2,80-10,20)	3,76	<b>3,80 A</b>	2,26(0,56-2,99)	1130	10,20		
25+25	2,50	2,50			5,00(1,90-6,80)	4,13	<b>6,10 A++</b>	1,21(0,27-2,43)	605	5,60	3,60	3,60							7,20(2,70-9,80)	3,71	<b>3,80 A</b>	1,94(0,64-3,02)	970	8,80		
25+35	2,50	3,50			6,00(1,90-6,90)	3,47	<b>6,10 A++</b>	1,73(0,27-2,44)	865	7,90	3,37	4,73							8,10(2,70-9,90)	3,60	<b>3,80 A</b>	2,25(0,63-3,02)	1125	10,20		
25+42	2,50	4,20			6,70(1,90-6,90)	2,94	<b>6,10 A++</b>	2,28(0,27-2,40)	1140	10,30	3,17	5,33							8,50(2,70-9,90)	3,48	<b>3,80 A</b>	2,44(0,62-3,03)	1220	11,00		
25+50	2,27	4,53			6,80(1,90-7,50)	3,49	<b>6,50 A++</b>	1,95(0,26-2,48)	975	8,80	2,83	5,67							8,50(2,80-10,20)	3,76	<b>3,80 A</b>	2,26(0,56-2,99)	1130	10,20		
25+60	2,00	4,80			6,80(1,90-7,50)	3,49	<b>6,50 A++</b>	1,95(0,26-2,48)	975	8,80	2,50	6,00							8,50(2,80-10,20)	3,76	<b>3,80 A</b>	2,26(0,56-2,99)	1130	10,20		
35+35	3,40	3,40			6,80(1,90-7,00)	2,97	<b>6,10 A++</b>	2,29(0,27-2,40)	1145	10,40	4,25	4,25							8,50(2,80-10,00)	3,56	<b>3,80 A</b>	2,39(0,64-3,02)	1195	10,80		
35+42	3,09	3,71			6,80(1,90-7,10)	3,04	<b>6,10 A++</b>	2,24(0,27-2,50)	1120	10,10	3,86	4,64							8,50(2,80-10,00)	3,56	<b>3,80 A</b>	2,39(0,60-3,02)	1195	10,80		
35+50	2,80	4,00			6,80(2,00-7,60)	3,64	<b>6,50 A++</b>	1,87(0,28-2,48)	935	8,50	3,50	5,00							8,50(2,80-10,30)	3,86	<b>3,80 A</b>	2,20(0,54-2,97)	1100	10,00		
35+60	2,51	4,29			6,80(2,00-7,60)	3,64	<b>6,50 A++</b>	1,87(0,28-2,48)	935	8,50	3,13	5,37							8,50(2,80-10,30)	3,86	<b>3,80 A</b>	2,20(0,54-2,97)	1100	10,00		
42+42	3,40	3,40			6,80(1,90-7,10)	3,02	<b>6,10 A++</b>	2,25(0,26-2,45)	1125	10,20	4,25	4,25							8,50(2,80-10,00)	3,57	<b>3,80 A</b>	2,38(0,60-2,98)	1190	10,80		
42+50	3,10	3,70			6,80(2,00-7,60)	3,64	<b>6,50 A++</b>	1,87(0,28-2,44)	935	8,50	3,88	4,62							8,50(2,80-10,30)	3,88	<b>3,80 A</b>	2,19(0,54-2,96)	1095	9,90		
42+60	2,80	4,00			6,80(2,00-7,60)	3,64	<b>6,50 A++</b>	1,87(0,28-2,44)	935	8,50	3,50	5,00							8,50(2,80-10,30)	3,88	<b>3,80 A</b>	2,19(0,54-2,96)	1095	9,90		
50+50	3,40	3,40			6,80(2,10-8,10)	4,10	<b>6,50 A++</b>	1,66(0,32-2,50)	830	7,60	4,25	4,25							8,50(2,80-10,50)	4,15	<b>3,80 A</b>	2,05(0,51-2,87)	1025	9,30		
50+60	3,09	3,71			6,80(2,10-8,10)	4,10	<b>6,50 A++</b>	1,66(0,32-2,50)	830	7,60	3,86	4,64							8							

Free Multi R32 combinations table

Free Multi 4x1 CU-4Z68TBE. Minimum capacity connected: 4,5 kW. Maximum capacity connected: 11,5 kW • R32 refrigerant

Table with columns: Indoor unit capacity, Cooling capacity (kW), Rooms, EER, SEER, Input power rating, A.E.C., Current, Heating capacity (kW), Rooms, COP, SCOP, Input power rating, A.E.C., Current. Rows include various combinations of indoor units and room counts.

1) Energy Label Scale from A+++ to D.

## Free Multi 4x1 CU-4Z80TBE. Minimum capacity connected: 4,5 kW. Maximum capacity connected: 14,7 kW • R32 refrigerant

Indoor unit capacity	Cooling capacity (kW). Rooms					EER	SEER <sup>1)</sup>	Input power rating			A.E.C.	Current	Heating capacity (kW). Rooms					COP	SCOP <sup>1)</sup>	Input power rating			A.E.C.	Current							
	A	B	C	D	Total (Min - Max)			W/W	kW	kWh			230V	A	B	C	D			Total (Min - Max)	W/W	kW			kWh	230V					
<b>1 Room</b>																															
16	1,60				1,60 (1,30 - 2,30)	4,00		0,40	0,25	0,64	200	2,00	2,60			2,60 (1,20 - 3,20)	4,33		0,60	0,30	0,96	300	3,00								
20	2,00				2,00 (1,80 - 2,90)	4,00		0,50	0,34	0,81	250	2,50	3,20			3,20 (1,20 - 4,10)	4,32		0,74	0,30	1,23	370	3,70								
25	2,50				2,50 (1,80 - 2,90)	3,97		0,63	0,34	0,81	315	3,20	3,60			3,60 (1,20 - 4,30)	3,83		0,94	0,30	1,23	470	4,70								
35	3,50				3,50 (1,80 - 4,10)	3,72		0,94	0,34	1,36	470	4,50	4,50			4,50 (1,20 - 5,80)	3,66		1,23	0,30	2,10	615	6,00								
42	4,20				4,20 (1,80 - 4,50)	3,07		1,37	0,34	1,99	685	6,40	5,60			5,60 (1,20 - 6,80)	3,26		1,72	0,30	2,93	860	8,00								
50	5,00				5,00 (1,90 - 5,70)	3,23		1,55	0,34	2,13	775	7,20	6,80			6,80 (1,20 - 6,90)	3,24		2,10	0,30	2,52	1050	9,70								
60	6,00				6,00 (1,90 - 6,20)	2,96		2,03	0,34	2,33	1015	9,20	8,50			8,50 (1,30 - 9,00)	3,54		2,40	0,62	2,55	1200	11,10								
71	7,10				7,10 (2,00 - 7,20)	2,81		2,53	0,37	2,77	1265	11,40	8,70			8,70 (1,40 - 9,20)	3,41		2,55	0,68	2,72	1275	11,80								
<b>2 Rooms</b>																															
16+16	1,60	1,60			3,20 (2,40 - 5,80)	4,38	<b>5,60 A+</b>	0,73	0,38	1,99	365	3,70	2,60	2,60		5,20 (2,20 - 8,20)	3,33	<b>3,90 A</b>	1,56	0,43	2,84	780	7,40								
16+20	1,60	2,00			3,60 (2,40 - 5,80)	4,14	<b>5,60 A+</b>	0,87	0,38	1,99	435	4,30	2,58	3,22		5,80 (2,20 - 8,20)	3,45	<b>3,90 A</b>	1,68	0,43	2,83	840	8,00								
16+25	1,60	2,50			4,10 (2,40 - 5,80)	3,83	<b>5,60 A+</b>	1,07	0,38	1,99	535	5,20	2,42	3,78		6,20 (2,20 - 8,20)	3,41	<b>3,90 A</b>	1,82	0,43	2,83	910	8,60								
16+35	1,60	3,50			5,10 (2,40 - 5,80)	3,45	<b>5,60 A+</b>	1,48	0,37	1,92	740	7,20	2,23	4,87		7,10 (2,20 - 8,60)	3,57	<b>3,90 A</b>	1,99	0,38	2,91	995	9,40								
16+42	1,60	4,20			5,80 (2,40 - 6,70)	3,19	<b>5,60 A+</b>	1,82	0,37	2,48	910	8,70	2,26	5,94		8,20 (2,20 - 9,80)	3,46	<b>3,90 A</b>	2,37	0,37	3,44	1185	11,10								
16+50	1,60	5,00			6,60 (2,40 - 7,20)	3,20	<b>6,10 A++</b>	2,06	0,35	2,48	1030	9,90	2,28	7,12		9,40 (2,20 - 10,00)	3,82	<b>4,10 A+</b>	2,46	0,32	3,25	1230	11,60								
16+60	1,60	6,00			7,60 (2,40 - 8,50)	2,83	<b>6,10 A++</b>	2,69	0,35	3,49	1345	12,90	1,98	7,42		9,40 (2,20 - 10,00)	3,82	<b>4,10 A+</b>	2,46	0,33	3,25	1230	11,60								
16+71	1,47	6,53			8,00 (2,50 - 8,50)	2,82	<b>6,10 A++</b>	2,84	0,38	3,34	1420	13,60	1,73	7,67		9,40 (2,20 - 10,30)	3,92	<b>4,10 A+</b>	2,40	0,32	3,42	1200	11,30								
20+20	2,00	2,00			4,00 (2,40 - 5,80)	3,96	<b>5,60 A+</b>	1,01	0,38	1,93	505	5,00	3,20	3,20		6,40 (2,20 - 8,20)	3,44	<b>3,90 A</b>	1,86	0,39	2,82	930	8,70								
20+25	2,00	2,50			4,50 (2,40 - 5,80)	3,63	<b>5,60 A+</b>	1,24	0,38	1,93	620	6,00	3,02	3,78		6,80 (2,20 - 8,20)	3,54	<b>3,90 A</b>	1,92	0,39	2,82	960	9,00								
20+35	2,00	3,50			5,50 (2,40 - 5,80)	3,33	<b>5,60 A+</b>	1,65	0,37	1,86	825	8,00	2,80	4,90		7,70 (2,20 - 8,60)	3,55	<b>3,90 A</b>	2,17	0,37	2,85	1085	10,20								
20+42	2,00	4,20			6,20 (2,40 - 7,20)	3,00	<b>5,60 A+</b>	2,07	0,37	2,90	1035	9,90	2,84	5,96		8,80 (2,20 - 10,00)	3,64	<b>3,90 A</b>	2,42	0,37	3,55	1210	11,40								
20+50	2,00	5,00			7,00 (2,40 - 8,10)	3,17	<b>6,10 A++</b>	2,21	0,35	3,10	1105	10,60	2,69	6,71		9,40 (2,20 - 10,00)	3,84	<b>4,10 A+</b>	2,45	0,32	3,23	1225	11,50								
20+60	2,00	6,00			8,00 (2,40 - 8,50)	2,75	<b>6,10 A++</b>	2,91	0,35	3,49	1455	13,90	2,35	7,05		9,40 (2,20 - 10,00)	3,84	<b>4,10 A+</b>	2,45	0,32	3,23	1225	11,50								
20+71	1,76	6,24			8,00 (2,50 - 8,50)	2,89	<b>6,10 A++</b>	2,77	0,38	3,34	1385	13,30	2,07	7,33		9,40 (2,20 - 10,30)	3,93	<b>4,10 A+</b>	2,39	0,32	3,40	1195	11,20								
25+25	2,50	2,50			5,00 (2,40 - 5,80)	3,50	<b>5,60 A+</b>	1,43	0,38	1,93	715	6,90	3,60	3,60		7,20 (2,20 - 8,60)	3,51	<b>3,90 A</b>	2,05	0,39	2,93	1025	9,60								
25+35	2,50	3,50			6,00 (2,40 - 6,70)	3,09	<b>5,60 A+</b>	1,94	0,37	2,48	970	9,30	3,37	4,73		8,10 (2,20 - 9,80)	3,49	<b>3,90 A</b>	2,32	0,37	3,44	1160	10,90								
25+42	2,50	4,20			6,70 (2,40 - 7,20)	2,78	<b>5,60 A+</b>	2,41	0,37	2,90	1205	11,50	3,43	5,77		9,20 (2,20 - 10,00)	3,58	<b>3,90 A</b>	2,57	0,37	3,55	1285	12,10								
25+50	2,50	5,00			7,50 (2,40 - 8,50)	2,94	<b>6,10 A++</b>	2,55	0,35	3,49	1275	12,20	3,13	6,27		9,40 (2,20 - 10,00)	3,84	<b>4,10 A+</b>	2,45	0,32	3,23	1225	11,50								
25+60	2,35	5,65			8,00 (2,50 - 8,50)	2,75	<b>6,10 A++</b>	2,91	0,39	3,49	1455	13,90	2,76	6,64		9,40 (2,20 - 10,00)	3,84	<b>4,10 A+</b>	2,45	0,32	3,23	1225	11,50								
25+71	2,08	5,92			8,00 (2,50 - 8,50)	2,89	<b>6,10 A++</b>	2,77	0,38	3,34	1385	13,30	2,45	6,95		9,40 (2,20 - 10,30)	3,93	<b>4,10 A+</b>	2,39	0,32	3,40	1195	11,20								
35+35	3,50	3,50			7,00 (2,40 - 8,10)	2,75	<b>5,60 A+</b>	2,55	0,37	3,63	1275	12,20	4,50	4,50		9,00 (2,20 - 10,00)	3,67	<b>3,90 A</b>	2,45	0,36	3,47	1225	11,50								
35+42	3,50	4,20			7,70 (2,40 - 8,50)	2,53	<b>5,60 A+</b>	3,04	0,37	4,12	1520	14,60	4,27	5,13		9,40 (2,20 - 10,00)	3,63	<b>3,90 A</b>	2,59	0,35	3,46	1295	12,20								
35+50	3,29	4,71			8,00 (2,50 - 8,50)	2,89	<b>6,10 A++</b>	2,77	0,38	3,34	1385	13,30	3,87	5,53		9,40 (2,20 - 10,00)	3,95	<b>4,10 A+</b>	2,38	0,32	3,20	1190	11,20								
35+60	2,95	5,05			8,00 (2,50 - 8,50)	2,89	<b>6,10 A++</b>	2,77	0,38	3,34	1385	13,30	3,46	5,94		9,40 (2,20 - 10,30)	3,95	<b>4,10 A+</b>	2,38	0,32	3,32	1190	11,20								
35+71	2,64	5,36			8,00 (2,50 - 8,60)	2,96	<b>6,10 A++</b>	2,70	0,38	3,34	1350	12,90	3,10	6,30		9,40 (2,20 - 10,50)	3,98	<b>4,10 A+</b>	2,36	0,31	3,43	1180	11,10								
42+42	4,00	4,00			8,00 (2,50 - 8,50)	2,40	<b>5,60 A+</b>	3,34	0,40	4,04	1670	16,00	4,70	4,70		9,40 (2,20 - 10,00)	3,64	<b>3,90 A</b>	2,58	0,35	3,45	1290	12,10								
42+50	3,65	4,35			8,00 (2,50 - 8,50)	2,89	<b>6,10 A++</b>	2,77	0,38	3,34	1385	13,30	4,29	5,11		9,40 (2,20 - 10,30)	3,98	<b>4,10 A+</b>	2,36	0,32	3,31	1180	11,10								
42+60	3,29	4,71			8,00 (2,50 - 8,60)	2,89	<b>6,10 A++</b>	2,77	0,38	3,42	1385	13,30	3,87	5,53		9,40 (2,20 - 10,30)	3,98	<b>4,10 A+</b>	2,36	0,32	3,31	1180	11,10								
42+71	2,97	5,03			8,00 (2,50 - 8,60)	2,96	<b>6,10 A++</b>	2,70	0,38	3,26	1350	12,90	3,49	5,91		9,40 (2,20 - 10,50)	4,00	<b>4,10 A+</b>	2,35	0,31	3,42	1175	11,00								
50+50	4,00	4,00			8,00 (2,50 - 8,60)	3,31	<b>6,10 A++</b>	2,42	0,38	2,95	1210	11,60	4,70	4,70		9,40 (2,20 - 10,30)	4,27	<b>4,10 A+</b>	2,20	0,31	3,09	1100	10,30								
50+60	3,64	4,36			8,00 (2,50 - 8,60)	3,31	<b>6,10 A++</b>	2,42	0,38	2,95	1210	11,60	4,27	5,13		9,40 (2,20 - 10,50)															

## Free Multi R32 combinations table

## Free Multi 4x1 CU-4Z80TBE. Minimum capacity connected: 4,5 kW. Maximum capacity connected: 14,7 kW • R32 refrigerant

Indoor unit capacity	Cooling capacity (kW). Rooms					EER	SEER <sup>1)</sup>	Input power rating			A.E.C.	Current	Heating capacity (kW). Rooms					COP	SCOP <sup>1)</sup>	Input power rating			A.E.C.	Current
	A	B	C	D	Total (Min - Max)			W/W	kW	kWh			230V	A	B	C	D			Total (Min - Max)	W/W	kW		
16+50+60	1,02	3,17	3,81		8,00(3,00-9,00)	4,17	<b>7,40 A++</b>	1,92(0,57-2,65)	960	9,20	1,19	3,73	4,48	9,40(3,20-10,60)	4,70	<b>4,40 A+</b>	2,00(0,57-2,93)	1000	9,40					
16+50+71	0,93	2,92	4,15		8,00(3,00-9,00)	4,17	<b>7,40 A++</b>	1,92(0,57-2,65)	960	9,20	1,10	3,43	4,87	9,40(3,20-10,60)	4,72	<b>4,40 A+</b>	1,99(0,59-2,92)	995	9,40					
16+60+60	0,94	3,53	3,53		8,00(3,00-9,00)	4,17	<b>7,40 A++</b>	1,92(0,57-2,65)	960	9,20	1,10	4,15	4,15	9,40(3,20-10,60)	4,70	<b>4,40 A+</b>	2,00(0,57-2,93)	1000	9,40					
16+60+71	0,87	3,27	3,86		8,00(3,00-9,00)	4,17	<b>7,40 A++</b>	1,92(0,57-2,65)	960	9,20	1,02	3,84	4,54	9,40(3,20-10,60)	4,72	<b>4,40 A+</b>	1,99(0,59-2,92)	995	9,40					
20+20+20	2,00	2,00	2,00		6,00(3,00-8,50)	4,00	<b>7,40 A++</b>	1,50(0,48-3,03)	750	7,30	3,13	3,13	3,13	9,39(3,20-10,40)	4,15	<b>4,30 A+</b>	2,26(0,49-3,24)	1130	10,60					
20+20+25	2,00	2,00	2,50		6,50(3,00-8,50)	3,76	<b>7,40 A++</b>	1,73(0,48-3,03)	865	8,40	2,89	2,89	3,62	9,40(3,20-10,40)	4,16	<b>4,30 A+</b>	2,26(0,49-3,24)	1130	10,60					
20+20+35	2,00	2,00	3,50		7,50(3,00-8,50)	3,64	<b>7,40 A++</b>	2,06(0,48-2,95)	1030	9,90	2,51	2,51	4,38	9,40(3,20-10,40)	4,22	<b>4,30 A+</b>	2,23(0,49-3,20)	1115	10,50					
20+20+42	1,95	1,95	4,10		8,00(3,00-8,60)	3,49	<b>7,40 A++</b>	2,29(0,48-3,03)	1145	11,00	2,29	2,29	4,82	9,40(3,20-10,40)	4,23	<b>4,40 A+</b>	2,22(0,48-3,19)	1110	10,40					
20+20+50	1,78	1,78	4,44		8,00(3,00-8,60)	3,92	<b>7,40 A++</b>	2,04(0,52-2,65)	1020	9,80	2,09	2,09	5,22	9,40(3,20-10,50)	4,45	<b>4,40 A+</b>	2,11(0,51-3,03)	1055	9,90					
20+20+60	1,60	1,60	4,80		8,00(3,00-8,80)	3,92	<b>7,40 A++</b>	2,04(0,52-2,80)	1020	9,80	1,88	1,88	5,64	9,40(3,20-10,50)	4,45	<b>4,40 A+</b>	2,11(0,51-3,03)	1055	9,90					
20+20+71	1,44	1,44	5,12		8,00(3,00-8,80)	3,92	<b>7,40 A++</b>	2,04(0,52-2,72)	1020	9,80	1,69	1,69	6,02	9,40(3,20-10,60)	4,48	<b>4,40 A+</b>	2,10(0,51-3,08)	1050	9,90					
20+25+25	2,00	2,50	2,50		7,00(3,00-8,50)	3,70	<b>7,40 A++</b>	1,89(0,48-3,03)	945	9,00	2,68	3,36	3,36	9,40(3,20-10,40)	4,16	<b>4,30 A+</b>	2,26(0,49-3,24)	1130	10,60					
20+25+35	2,00	2,50	3,50		8,00(3,00-8,60)	3,49	<b>7,40 A++</b>	2,29(0,48-3,03)	1145	11,00	2,35	2,94	4,11	9,40(3,20-10,40)	4,22	<b>4,40 A+</b>	2,23(0,49-3,20)	1115	10,50					
20+25+42	1,84	2,30	3,86		8,00(3,00-8,60)	3,49	<b>7,40 A++</b>	2,29(0,48-3,03)	1145	11,00	2,16	2,70	4,54	9,40(3,20-10,50)	4,23	<b>4,40 A+</b>	2,22(0,48-3,25)	1110	10,40					
20+25+50	1,68	2,11	4,21		8,00(3,00-8,60)	3,92	<b>7,40 A++</b>	2,04(0,52-2,65)	1020	9,80	1,98	2,47	4,95	9,40(3,20-10,50)	4,45	<b>4,40 A+</b>	2,11(0,51-3,03)	1055	9,90					
20+25+60	1,52	1,90	4,58		8,00(3,00-8,80)	3,92	<b>7,40 A++</b>	2,04(0,52-2,80)	1020	9,80	1,79	2,24	5,37	9,40(3,20-10,50)	4,45	<b>4,40 A+</b>	2,11(0,51-3,03)	1055	9,90					
20+25+71	1,38	1,72	4,90		8,00(3,00-8,80)	3,92	<b>7,40 A++</b>	2,04(0,52-2,72)	1020	9,80	1,62	2,03	5,75	9,40(3,20-10,60)	4,48	<b>4,40 A+</b>	2,10(0,51-3,08)	1050	9,90					
20+35+35	1,78	3,11	3,11		8,00(3,00-8,60)	3,59	<b>7,40 A++</b>	2,23(0,48-2,95)	1115	10,70	2,08	3,66	3,66	9,40(3,20-10,50)	4,27	<b>4,40 A+</b>	2,20(0,48-3,16)	1100	10,30					
20+35+42	1,65	2,89	3,46		8,00(3,00-8,60)	3,59	<b>7,40 A++</b>	2,23(0,48-2,95)	1115	10,70	1,94	3,39	4,07	9,40(3,20-10,50)	4,29	<b>4,40 A+</b>	2,19(0,48-3,15)	1095	10,30					
20+35+50	1,52	2,67	3,81		8,00(3,00-8,80)	3,92	<b>7,40 A++</b>	2,04(0,52-2,80)	1020	9,80	1,79	3,13	4,48	9,40(3,20-10,50)	4,50	<b>4,40 A+</b>	2,09(0,51-3,00)	1045	9,80					
20+35+60	1,39	2,43	4,18		8,00(3,00-8,80)	3,92	<b>7,40 A++</b>	2,04(0,52-2,80)	1020	9,80	1,63	2,86	4,91	9,40(3,20-10,60)	4,50	<b>4,40 A+</b>	2,09(0,51-3,06)	1045	9,80					
20+35+71	1,27	2,22	4,51		8,00(3,00-9,00)	4,04	<b>7,40 A++</b>	1,98(0,52-2,80)	990	9,50	1,49	2,61	5,30	9,40(3,20-10,60)	4,54	<b>4,40 A+</b>	2,07(0,51-3,04)	1035	9,70					
20+42+42	1,54	3,23	3,23		8,00(3,00-8,80)	3,59	<b>7,40 A++</b>	2,23(0,48-3,03)	1115	10,70	1,80	3,80	3,80	9,40(3,20-10,50)	4,31	<b>4,40 A+</b>	2,18(0,48-3,14)	1090	10,20					
20+42+50	1,43	3,00	3,57		8,00(3,00-8,80)	3,92	<b>7,40 A++</b>	2,04(0,52-2,72)	1020	9,80	1,68	3,53	4,19	9,40(3,20-10,60)	4,52	<b>4,40 A+</b>	2,08(0,51-3,05)	1040	9,80					
20+42+60	1,31	2,75	3,94		8,00(3,00-9,00)	3,92	<b>7,40 A++</b>	2,04(0,52-2,87)	1020	9,80	1,54	3,24	4,62	9,40(3,20-10,60)	4,52	<b>4,40 A+</b>	2,08(0,51-3,05)	1040	9,80					
20+42+71	1,20	2,53	4,27		8,00(3,00-9,00)	4,04	<b>7,40 A++</b>	1,98(0,52-2,80)	990	9,50	1,41	2,97	5,02	9,40(3,20-10,60)	4,54	<b>4,40 A+</b>	2,07(0,52-3,03)	1035	9,70					
20+50+50	1,33	3,33	3,33		7,99(3,00-9,00)	4,16	<b>7,40 A++</b>	1,92(0,57-2,65)	960	9,20	1,56	3,92	3,92	9,40(3,20-10,60)	4,72	<b>4,40 A+</b>	1,99(0,59-2,92)	995	9,40					
20+50+60	1,23	3,08	3,69		8,00(3,00-9,00)	4,17	<b>7,40 A++</b>	1,92(0,57-2,65)	960	9,20	1,45	3,62	4,33	9,40(3,20-10,60)	4,72	<b>4,40 A+</b>	1,99(0,59-2,92)	995	9,40					
20+50+71	1,13	2,84	4,03		8,00(3,00-9,00)	4,17	<b>7,40 A++</b>	1,92(0,57-2,65)	960	9,20	1,33	3,33	4,74	9,40(3,20-10,60)	4,75	<b>4,40 A+</b>	1,98(0,60-2,91)	990	9,30					
20+60+60	1,14	3,43	3,43		8,00(3,00-9,00)	4,17	<b>7,40 A++</b>	1,92(0,57-2,65)	960	9,20	1,34	4,03	4,03	9,40(3,20-10,60)	4,72	<b>4,40 A+</b>	1,99(0,59-2,92)	995	9,40					
25+25+25	2,50	2,50	2,50		7,50(3,00-8,50)	3,52	<b>7,40 A++</b>	2,13(0,48-3,03)	1065	10,20	3,13	3,13	3,13	9,39(3,20-10,40)	4,15	<b>4,30 A+</b>	2,26(0,49-3,24)	1130	10,60					
25+25+35	2,35	2,35	3,30		8,00(3,00-8,60)	3,49	<b>7,40 A++</b>	2,29(0,48-3,03)	1145	11,00	2,76	2,76	3,88	9,40(3,20-10,40)	4,22	<b>4,40 A+</b>	2,23(0,49-3,20)	1115	10,50					
25+25+42	2,17	2,17	3,66		8,00(3,00-8,60)	3,49	<b>7,40 A++</b>	2,29(0,48-3,03)	1145	11,00	2,55	2,55	4,30	9,40(3,20-10,50)	4,23	<b>4,40 A+</b>	2,22(0,48-3,25)	1110	10,40					
25+25+50	2,00	2,00	4,00		8,00(3,00-8,80)	3,92	<b>7,40 A++</b>	2,04(0,52-2,80)	1020	9,80	2,35	2,35	4,70	9,40(3,20-10,50)	4,45	<b>4,40 A+</b>	2,11(0,51-3,03)	1055	9,90					
25+25+60	1,82	1,82	4,36		8,00(3,00-8,80)	3,92	<b>7,40 A++</b>	2,04(0,52-2,80)	1020	9,80	2,14	2,14	5,12	9,40(3,20-10,50)	4,45	<b>4,40 A+</b>	2,11(0,51-3,03)	1055	9,90					
25+25+71	1,65	1,65	4,70		8,00(3,00-9,00)	3,92	<b>7,40 A++</b>	2,04(0,52-2,87)	1020	9,80	1,94	1,94	5,52	9,40(3,20-10,60)	4,48	<b>4,40 A+</b>	2,10(0,51-3,08)	1050	9,90					
25+35+35	2,10	2,95	2,95		8,00(3,00-8,60)	3,59	<b>7,40 A++</b>	2,23(0,48-2,95)	1115	10,70	2,48	3,46	3,46	9,40(3,20-10,50)	4,27	<b>4,40 A+</b>	2,20(0,48-3,16)	1100	10,30					
25+35+42	1,96	2,75	3,29		8,00(3,00-8,80)	3,59	<b>7,40 A++</b>	2,23(0,48-3,10)	1115	10,70	2,30	3,23	3,87	9,40(3,20-10,50)	4,29	<b>4,40 A+</b>	2,19(0,48-3,15)	1095	10,30					
25+35+50	1,82	2,55	3,63		8,00(3,00-8,80)	3,92	<b>7,40 A++</b>	2,04(0,52-2,80)	1020	9,80	2,14	2,99	4,27	9,40(3,20-10,50)	4,50	<b>4,40 A+</b>	2,09(0,51-3,00)	1045	9,80					
25+35+60	1,67	2,33	4,00		8,00(3,00-9,00)	3,92	<b>7,40 A++</b>	2,04(0,52-2,87)	1020	9,80	1,96	2,74	4,70	9,40(3,20-10,60)	4,50	<b>4,40 A+</b>	2,09(0,51-3,06)	1045	9,80					
25+35+71	1,53	2,14	4,33		8,00(3,00-9,00)	4,04	<b>7,40 A++</b>	1,98(0,52-2,80)	990	9,50	1,79	2,51	5,10	9,40(3,20-10,60)	4,54	<b>4,40 A+</b>	2,07(0,51-3,04)	1035	9,70					
25+42+42	1,84	3,08	3,08		8,00(3,00-8,80)	3,59	<b>7,40 A++</b>	2,23(0,48-3,03)	1115	10,70	2,16	3,62	3,62	9,40(3,20-10,50)	4,31	<b>4,40 A+</b>	2,18(0,48-3,14)	1090	10,20					
25+42+50	1,71	2,87	3,42		8,00(3,00-8,80)	3,92	<b>7,40 A++</b>	2,04(0,52-2,72)	1020	9,80	2,01	3,37	4,02	9,40(3,20-10,60)	4,52	<b>4,40 A+</b>	2,08(0,51-3,05)	1040	9,80					
25+42+60	1,57	2,65	3,78		8,00(3,00-9,00)	3,92	<b>7,40 A++</b>	2,04(0,52-2,87)	1020	9,80	1,85	3,11	4,44	9,40(3,20-10,60)	4,52	<b>4,40 A+</b>	2,08(0,51-3,05)	1040	9,80					
25+42+71	1,45	2,43	4,12		8,00(3,00-9,00)	4,04	<b>7,40 A++</b>	1,98(0,52-2,80)	990	9,50	1,70	2,86	4,84	9,40(3,20-10,60)	4,54	<b>4,40 A+</b>	2,07(0,52-3,03)	1035	9,70					
25+50+50	1,60	3,20	3,20		8,00(3,00-9,00)	4,17	<b>7,40 A++</b>	1,92(0,57-2,65)	960	9,20	1,88	3,76	3,76	9,40(3,20-10,60)	4,72	<b>4,40 A+</b>	1,99(0,59-2,92)	995	9,40					
25+50+60	1,48	2,96	3,56		8,00(3,00-9,00)	4,17	<b>7,40 A++</b>	1,92(0,57-2,65)	960	9,20	1,74	3,48	4,18	9,40(3,20-10,60)	4,72	<b>4,40 A+</b>	1,99(0,59-2,92)	995	9,40					
25+50+71	1,37	2,74	3,89		8,00(3,00-9,00)	4,17	<b>7,40 A++</b>	1,92(0,57-2,65)	960	9,20	1,61	3,22	4,57	9,40(3,20-10,60)	4,75	<b>4,40 A+</b>	1,98(0,60-2,91)	990	9,30					
25+60+60	1,38	3,31	3,31		8,00(3,00-9,00)	4,17	<b>7,40 A++</b>	1,92(0,57-2,65)	960	9,20	1,62	3,89	3,89	9,40(3,20-10,60)	4,72	<b>4,40 A+</b>	1,99(0,59-2,92)	995	9,40					
35+35+35	2,66	2,66	2,66		7,98(3,00-8,80)	3,68	<b>7,40 A++</b>	2,17(0,48-3,03)	1085	10,40	3,13	3,13	3,13	9,39(3,20-10,50)	4,31	<b>4,40 A+</b>	2,18(0,48-3,13)	1090	10,20					
35+35+42	2,50	2,50	3,00		8,0																			

## Free Multi 4x1 CU-4Z80TBE. Minimum capacity connected: 4,5 kW. Maximum capacity connected: 14,7 kW • R32 refrigerant

Indoor unit capacity	Cooling capacity (kW). Rooms					EER	SEER <sup>1)</sup>	Input power rating			A.E.C.	Current	Heating capacity (kW). Rooms					COP	SCOP <sup>1)</sup>	Input power rating			A.E.C.	Current			
	A	B	C	D	Total (Min - Max)			W/W	kW				W/W	A	B	C	D			Total (Min - Max)	W/W	kW					
										kWh			230V													kWh	230V
16+16+20+71	1,04	1,04	1,30	4,62	8,00(3,00-9,20)	4,28	<b>7,90 A++</b>	1,87(0,62-2,66)	935	9,00	1,22	1,22	1,53	5,43	9,40(4,20-10,60)	4,75	<b>4,70 A++</b>	1,98(0,79-2,90)	990	9,30							
16+16+25+25	1,56	1,56	2,44	2,44	8,00(3,00-9,20)	4,04	<b>7,90 A++</b>	1,98(0,53-2,87)	990	9,50	1,83	1,83	2,87	2,87	9,40(4,20-10,60)	4,59	<b>4,70 A++</b>	2,05(0,68-3,01)	1025	9,60							
16+16+25+35	1,39	1,39	2,17	3,05	8,00(3,00-9,20)	4,17	<b>7,90 A++</b>	1,92(0,53-2,87)	960	9,20	1,63	1,63	2,55	3,59	9,40(4,20-10,60)	4,63	<b>4,70 A++</b>	2,03(0,69-2,98)	1015	9,50							
16+16+25+42	1,29	1,29	2,02	3,40	8,00(3,00-9,20)	4,17	<b>7,90 A++</b>	1,92(0,56-2,87)	960	9,20	1,52	1,52	2,37	3,99	9,40(4,20-10,60)	4,65	<b>4,70 A++</b>	2,02(0,71-2,97)	1010	9,50							
16+16+25+50	1,20	1,20	1,87	3,73	8,00(3,00-9,20)	4,28	<b>7,90 A++</b>	1,87(0,62-2,65)	935	9,00	1,41	1,41	2,20	4,38	9,40(4,20-10,60)	4,72	<b>4,70 A++</b>	1,99(0,77-2,85)	995	9,40							
16+16+25+60	1,09	1,09	1,71	4,11	8,00(3,00-9,20)	4,28	<b>7,90 A++</b>	1,87(0,62-2,65)	935	9,00	1,29	1,29	2,01	4,81	9,40(4,20-10,60)	4,72	<b>4,70 A++</b>	1,99(0,77-2,85)	995	9,40							
16+16+25+71	1,00	1,00	1,56	4,44	8,00(3,00-9,20)	4,28	<b>7,90 A++</b>	1,87(0,62-2,66)	935	9,00	1,18	1,18	1,84	5,20	9,40(4,20-10,60)	4,75	<b>4,70 A++</b>	1,98(0,79-2,90)	990	9,30							
16+16+35+35	1,25	1,25	2,75	2,75	8,00(3,00-9,20)	4,17	<b>7,90 A++</b>	1,92(0,57-2,80)	960	9,20	1,47	1,47	3,23	3,23	9,40(4,20-10,60)	4,68	<b>4,70 A++</b>	2,01(0,72-2,95)	1005	9,40							
16+16+35+42	1,17	1,17	2,57	3,09	8,00(3,00-9,20)	4,17	<b>7,90 A++</b>	1,92(0,57-2,80)	960	9,20	1,38	1,38	3,02	3,62	9,40(4,20-10,60)	4,70	<b>4,70 A++</b>	2,00(0,72-2,94)	1000	9,40							
16+16+35+50	1,09	1,09	2,39	3,43	8,00(3,00-9,20)	4,28	<b>7,90 A++</b>	1,87(0,62-2,66)	935	9,00	1,29	1,29	2,81	4,01	9,40(4,20-10,60)	4,75	<b>4,70 A++</b>	1,98(0,80-2,89)	990	9,30							
16+16+35+60	1,01	1,01	2,20	3,78	8,00(3,00-9,20)	4,28	<b>7,90 A++</b>	1,87(0,62-2,66)	935	9,00	1,18	1,18	2,59	4,45	9,40(4,20-10,60)	4,75	<b>4,70 A++</b>	1,98(0,80-2,89)	990	9,30							
16+16+35+71	0,93	0,93	2,03	4,11	8,00(3,00-9,20)	4,28	<b>7,90 A++</b>	1,87(0,63-2,66)	935	9,00	1,09	1,09	2,38	4,84	9,40(4,20-10,60)	4,77	<b>4,70 A++</b>	1,97(0,80-2,87)	985	9,30							
16+16+42+42	1,10	1,10	2,90	2,90	8,00(3,00-9,20)	4,17	<b>7,90 A++</b>	1,92(0,57-2,80)	960	9,20	1,30	1,30	3,40	3,40	9,40(4,20-10,60)	4,70	<b>4,70 A++</b>	2,00(0,72-2,93)	1000	9,40							
16+16+42+50	1,03	1,03	2,71	3,23	8,00(3,00-9,20)	4,28	<b>7,90 A++</b>	1,87(0,62-2,66)	935	9,00	1,21	1,21	3,18	3,80	9,40(4,20-10,60)	4,77	<b>4,70 A++</b>	1,97(0,80-2,88)	985	9,30							
16+16+42+60	0,96	0,96	2,51	3,57	8,00(3,00-9,20)	4,28	<b>7,90 A++</b>	1,87(0,62-2,66)	935	9,00	1,12	1,12	2,95	4,21	9,40(4,20-10,60)	4,77	<b>4,70 A++</b>	1,97(0,80-2,88)	985	9,30							
16+16+42+71	0,88	0,88	2,32	3,92	8,00(3,00-9,20)	4,28	<b>7,90 A++</b>	1,87(0,63-2,66)	935	9,00	1,04	1,04	2,72	4,60	9,40(4,20-10,60)	4,77	<b>4,70 A++</b>	1,97(0,81-2,87)	985	9,30							
16+16+50+50	0,97	0,97	3,03	3,03	8,00(3,00-9,20)	4,26	<b>7,90 A++</b>	1,88(0,69-2,60)	940	9,00	1,14	1,14	3,56	3,56	9,40(4,20-10,60)	4,68	<b>4,70 A++</b>	2,01(0,92-2,85)	1005	9,40							
16+16+50+60	0,90	0,90	2,82	3,38	8,00(3,00-9,20)	4,26	<b>7,90 A++</b>	1,88(0,69-2,60)	940	9,00	1,06	1,06	3,31	3,97	9,40(4,20-10,60)	4,68	<b>4,70 A++</b>	2,01(0,92-2,85)	1005	9,40							
16+20+20+20	1,60	2,00	2,00	2,00	7,60(3,00-9,20)	4,06	<b>7,90 A++</b>	1,87(0,53-2,87)	935	9,00	1,99	2,47	2,47	2,47	9,40(4,20-10,60)	4,61	<b>4,70 A++</b>	2,04(0,69-3,00)	1020	9,60							
16+20+20+25	1,58	1,98	1,98	2,46	8,00(3,00-9,20)	4,04	<b>7,90 A++</b>	1,98(0,53-2,87)	990	9,50	1,86	2,32	2,32	2,90	9,40(4,20-10,60)	4,61	<b>4,70 A++</b>	2,04(0,69-3,00)	1020	9,60							
16+20+20+35	1,41	1,76	1,76	3,07	8,00(3,00-9,20)	4,17	<b>7,90 A++</b>	1,92(0,57-2,80)	960	9,20	1,65	2,07	2,07	3,61	9,40(4,20-10,60)	4,65	<b>4,70 A++</b>	2,02(0,71-2,97)	1010	9,50							
16+20+20+42	1,31	1,63	1,63	3,43	8,00(3,00-9,20)	4,17	<b>7,90 A++</b>	1,92(0,57-2,80)	960	9,20	1,53	1,92	1,92	4,03	9,40(4,20-10,60)	4,68	<b>4,70 A++</b>	2,01(0,71-2,96)	1005	9,40							
16+20+20+50	1,21	1,51	1,51	3,77	8,00(3,00-9,20)	4,28	<b>7,90 A++</b>	1,87(0,62-2,65)	935	9,00	1,42	1,77	1,77	4,44	9,40(4,20-10,60)	4,72	<b>4,70 A++</b>	1,99(0,79-2,90)	995	9,40							
16+20+20+60	1,10	1,38	1,38	4,14	8,00(3,00-9,20)	4,28	<b>7,90 A++</b>	1,87(0,62-2,65)	935	9,00	1,30	1,62	1,62	4,86	9,40(4,20-10,60)	4,72	<b>4,70 A++</b>	1,99(0,79-2,90)	995	9,40							
16+20+20+71	1,01	1,26	1,26	4,47	8,00(3,00-9,20)	4,28	<b>7,90 A++</b>	1,87(0,63-2,66)	935	9,00	1,18	1,48	1,48	5,26	9,40(4,20-10,60)	4,75	<b>4,70 A++</b>	1,98(0,80-2,89)	990	9,30							
16+20+25+25	1,48	1,86	2,33	2,33	8,00(3,00-9,20)	4,04	<b>7,90 A++</b>	1,98(0,53-2,87)	990	9,50	1,75	2,19	2,73	2,73	9,40(4,20-10,60)	4,61	<b>4,70 A++</b>	2,04(0,69-3,00)	1020	9,60							
16+20+25+35	1,33	1,67	2,08	2,92	8,00(3,00-9,20)	4,17	<b>7,90 A++</b>	1,92(0,57-2,80)	960	9,20	1,57	1,96	2,45	3,42	9,40(4,20-10,60)	4,65	<b>4,70 A++</b>	2,02(0,71-2,97)	1010	9,50							
16+20+25+42	1,24	1,55	1,94	3,27	8,00(3,00-9,20)	4,17	<b>7,90 A++</b>	1,92(0,57-2,80)	960	9,20	1,46	1,83	2,28	3,83	9,40(4,20-10,60)	4,68	<b>4,70 A++</b>	2,01(0,71-2,96)	1005	9,40							
16+20+25+50	1,15	1,44	1,80	3,61	8,00(3,00-9,20)	4,28	<b>7,90 A++</b>	1,87(0,62-2,65)	935	9,00	1,35	1,69	2,12	4,24	9,40(4,20-10,60)	4,72	<b>4,70 A++</b>	1,99(0,79-2,90)	995	9,40							
16+20+25+60	1,06	1,32	1,65	3,97	8,00(3,00-9,20)	4,28	<b>7,90 A++</b>	1,87(0,62-2,65)	935	9,00	1,24	1,55	1,94	4,67	9,40(4,20-10,60)	4,72	<b>4,70 A++</b>	1,99(0,79-2,90)	995	9,40							
16+20+25+71	0,97	1,21	1,52	4,30	8,00(3,00-9,20)	4,28	<b>7,90 A++</b>	1,87(0,63-2,66)	935	9,00	1,14	1,42	1,78	5,06	9,40(4,20-10,60)	4,75	<b>4,70 A++</b>	1,98(0,80-2,89)	990	9,30							
16+20+35+35	1,21	1,51	2,64	2,64	8,00(3,00-9,20)	4,17	<b>7,90 A++</b>	1,92(0,57-2,80)	960	9,20	1,42	1,78	3,10	3,10	9,40(4,20-10,60)	4,70	<b>4,70 A++</b>	2,00(0,72-2,94)	1000	9,40							
16+20+35+42	1,13	1,42	2,48	2,97	8,00(3,00-9,20)	4,17	<b>7,90 A++</b>	1,92(0,57-2,80)	960	9,20	1,33	1,66	2,91	3,50	9,40(4,20-10,60)	4,70	<b>4,70 A++</b>	2,00(0,72-2,93)	1000	9,40							
16+20+35+50	1,06	1,32	2,31	3,31	8,00(3,00-9,20)	4,28	<b>7,90 A++</b>	1,87(0,63-2,66)	935	9,00	1,24	1,55	2,72	3,89	9,40(4,20-10,60)	4,77	<b>4,70 A++</b>	1,97(0,80-2,88)	985	9,30							
16+20+35+60	0,98	1,22	2,14	3,66	8,00(3,00-9,20)	4,28	<b>7,90 A++</b>	1,87(0,63-2,66)	935	9,00	1,15	1,44	2,51	4,30	9,40(4,20-10,60)	4,77	<b>4,70 A++</b>	1,97(0,80-2,88)	985	9,30							
16+20+35+71	0,90	1,13	1,97	4,00	8,00(3,00-9,20)	4,28	<b>7,90 A++</b>	1,87(0,63-2,66)	935	9,00	1,06	1,32	2,32	4,70	9,40(4,20-10,60)	4,77	<b>4,70 A++</b>	1,97(0,81-2,87)	985	9,30							
16+20+42+42	1,07	1,33	2,80	2,80	8,00(3,00-9,20)	4,17	<b>7,90 A++</b>	1,92(0,57-2,80)	960	9,20	1,25	1,57	3,29	3,29	9,40(4,20-10,60)	4,72	<b>4,70 A++</b>	1,99(0,72-2,92)	995	9,40							
16+20+42+50	1,00	1,25	2,63	3,12	8,00(3,00-9,20)	4,28	<b>7,90 A++</b>	1,87(0,63-2,66)	935	9,00	1,18	1,47	3,08	3,67	9,40(4,20-10,60)	4,77	<b>4,70 A++</b>	1,97(0,81-2,87)	985	9,30							
16+20+42+60	0,93	1,16	2,43	3,48	8,00(3,00-9,20)	4,28	<b>7,90 A++</b>	1,87(0,63-2,66)	935	9,00	1,09	1,36	2,86	4,09	9,40(4,20-10,60)	4,77	<b>4,70 A++</b>	1,97(0,81-2,87)	985	9,30							
16+20+50+50	0,94	1,18	2,94	2,94	8,00(3,00-9,20)	4,23	<b>7,90 A++</b>	1,89(0,69-2,60)	945	9,00	1,10	1,38	3,46	3,46	9,40(4,20-10,60)	4,68	<b>4,70 A++</b>	2,01(0,93-2,90)	1005	9,40							
16+20+50+60	0,88	1,10	2,74	3,28	8,00(3,00-9,20)	4,23	<b>7,90 A++</b>	1,89(0,69-2,60)	945	9,00	1,03	1,29	3,22	3,86	9,40(4,20-10,60)	4,68	<b>4,70 A++</b>	2,01(0,93-2,90)	1005	9,40							
16+25+25+25	1,40	2,20	2,20	2,20	8,00(3,00-9,20)	4,04	<b>7,90 A++</b>	1,98(0,53-2,87)	990	9,50	1,66	2,58	2,58	2,58	9,40(4,20-10,60)	4,61	<b>4,70 A++</b>	2,04(0,69-3,00)	1020	9,60							
16+25+25+35	1,27	1,98	1,98	2,77	8,00(3,00-9,20)	4,17	<b>7,90 A++</b>	1,92(0,57-2,80)	960	9,20	1,49	2,33	3,33	3,25	9,40(4,20-10,60)	4,65	<b>4,70 A++</b>	2,02(0,71-2,97)	1010	9,50							
16+25+25+42	1,19	1,85	1,85	3,11	8,00(3,00-9,20)	4,17	<b>7,90 A++</b>	1,92(0,57-2,80)	960	9,20	1,39	2,18	2,18	3,65	9,40(4,20-10,60)	4,68	<b>4,70 A++</b>	2,01(0,71-2,96)	1005	9,40							
16+25+25+50	1,10	1,72	1,72	3,46	8,00(3,00-9,20)	4,28	<b>7,90 A++</b>	1,87(0,62-2,65)	935	9,00	1,30	2,03	2,03	4,04	9,40(4,20-10,60)	4,72	<b>4,70 A++</b>	1,99(0,79-2,90)	995	9,40							
16+25+25+60	1,02	1,59	1,59	3,80	8,00(3,00-9,20)	4,28	<b>7,90 A++</b>	1,87(0,62-2,65)	935	9,00	1,19	1,87	1,87	4,47	9,40(4,20-10,60)	4,72	<b>4,70 A++</b>	1,99(0,79-2,90)	995	9,40							
16+25+25+71	0,93	1,46	1,46	4,15	8,00(3,00-9,20)	4,28	<b>7,90 A++</b>	1,87(0,63-2,66)	935	9,00	1,10	1,72	1,72	4,86													

## Free Multi R32 combinations table

## Free Multi 4x1 CU-4Z80TBE. Minimum capacity connected: 4,5 kW. Maximum capacity connected: 14,7 kW • R32 refrigerant

Indoor unit capacity	Cooling capacity (kW). Rooms					EER	SEER <sup>1)</sup>	Input power rating			Heating capacity (kW). Rooms					COP	SCOP <sup>1)</sup>	Input power rating			A.E.C.	Current
	A	B	C	D	Total (Min - Max)			W/W	kW	kWh	230V	A	B	C	D			Total (Min - Max)	W/W	kW		
20+20+35+50	1,28	1,28	2,24	3,20	8,00(3,00-9,20)	4,28	<b>7,90 A++</b>	1,87(0,63-2,66)	935	9,00	1,50	1,50	2,63	3,77	9,40(4,20-10,60)	4,77	<b>4,70 A++</b>	1,97(0,81-2,87)	985	9,30		
20+20+35+60	1,19	1,19	2,07	3,55	8,00(3,00-9,20)	4,28	<b>7,90 A++</b>	1,87(0,63-2,66)	935	9,00	1,39	1,39	2,44	4,18	9,40(4,20-10,60)	4,77	<b>4,70 A++</b>	1,97(0,81-2,87)	985	9,30		
20+20+35+71	1,10	1,10	1,92	3,88	8,00(3,00-9,20)	4,28	<b>7,90 A++</b>	1,87(0,63-2,66)	935	9,00	1,29	1,29	2,25	4,57	9,40(4,20-10,60)	4,70	<b>4,70 A++</b>	2,00(0,83-2,86)	1000	9,40		
20+20+42+42	1,29	1,29	2,71	2,71	8,00(3,00-9,20)	4,17	<b>7,90 A++</b>	1,92(0,57-2,80)	960	9,20	1,52	1,52	3,18	3,18	9,40(4,20-10,60)	4,75	<b>4,70 A++</b>	1,98(0,72-2,91)	990	9,30		
20+20+42+50	1,21	1,21	2,55	3,03	8,00(3,00-9,20)	4,28	<b>7,90 A++</b>	1,87(0,63-2,66)	935	9,00	1,42	1,42	2,99	3,57	9,40(4,20-10,60)	4,70	<b>4,70 A++</b>	2,00(0,81-2,86)	1000	9,40		
20+20+42+60	1,13	1,13	2,37	3,37	8,00(3,00-9,20)	4,28	<b>7,90 A++</b>	1,87(0,63-2,66)	935	9,00	1,32	1,32	2,78	3,98	9,40(4,20-10,60)	4,70	<b>4,70 A++</b>	2,00(0,81-2,86)	1000	9,40		
20+20+50+50	1,14	1,14	2,86	2,86	8,00(3,00-9,20)	4,23	<b>7,90 A++</b>	1,89(0,70-2,60)	945	9,00	1,34	1,34	3,36	3,36	9,40(4,20-10,60)	4,68	<b>4,70 A++</b>	2,01(0,94-2,89)	1005	9,40		
20+25+25+25	1,67	2,11	2,11	2,11	8,00(3,00-9,20)	4,04	<b>7,90 A++</b>	1,98(0,53-2,87)	990	9,50	1,99	2,47	2,47	2,47	9,40(4,20-10,60)	4,63	<b>4,70 A++</b>	2,03(0,69-2,99)	1015	9,50		
20+25+25+35	1,52	1,90	1,90	2,68	8,00(3,00-9,20)	4,17	<b>7,90 A++</b>	1,92(0,57-2,80)	960	9,20	1,79	2,24	2,24	3,13	9,40(4,20-10,60)	4,68	<b>4,70 A++</b>	2,01(0,71-2,96)	1005	9,40		
20+25+25+42	1,43	1,79	1,79	2,99	8,00(3,00-9,20)	4,17	<b>7,90 A++</b>	1,92(0,57-2,80)	960	9,20	1,68	2,10	2,10	3,52	9,40(4,20-10,60)	4,68	<b>4,70 A++</b>	2,01(0,72-2,95)	1005	9,40		
20+25+25+50	1,33	1,67	1,67	3,33	8,00(3,00-9,20)	4,28	<b>7,90 A++</b>	1,87(0,62-2,65)	935	9,00	1,57	1,96	1,96	3,91	9,40(4,20-10,60)	4,75	<b>4,70 A++</b>	1,98(0,80-2,89)	990	9,30		
20+25+25+60	1,23	1,54	1,54	3,69	8,00(3,00-9,20)	4,28	<b>7,90 A++</b>	1,87(0,62-2,65)	935	9,00	1,45	1,81	1,81	4,33	9,40(4,20-10,60)	4,75	<b>4,70 A++</b>	1,98(0,80-2,89)	990	9,30		
20+25+25+71	1,13	1,42	1,42	4,03	8,00(3,00-9,20)	4,28	<b>7,90 A++</b>	1,87(0,63-2,66)	935	9,00	1,33	1,67	1,67	4,73	9,40(4,20-10,60)	4,77	<b>4,70 A++</b>	1,97(0,80-2,88)	985	9,30		
20+25+35+35	1,39	1,75	2,43	2,43	8,00(3,00-9,20)	4,17	<b>7,90 A++</b>	1,92(0,57-2,80)	960	9,20	1,63	2,05	2,86	2,86	9,40(4,20-10,60)	4,70	<b>4,70 A++</b>	2,00(0,72-2,93)	1000	9,40		
20+25+35+42	1,31	1,64	2,30	2,75	8,00(3,00-9,20)	4,17	<b>7,90 A++</b>	1,92(0,57-2,80)	960	9,20	1,54	1,93	2,70	3,23	9,40(4,20-10,60)	4,72	<b>4,70 A++</b>	1,99(0,72-2,92)	995	9,40		
20+25+35+50	1,23	1,54	2,15	3,08	8,00(3,00-9,20)	4,28	<b>7,90 A++</b>	1,87(0,63-2,66)	935	9,00	1,45	1,81	2,53	3,61	9,40(4,20-10,60)	4,77	<b>4,70 A++</b>	1,97(0,81-2,87)	985	9,30		
20+25+35+60	1,14	1,43	2,00	3,43	8,00(3,00-9,20)	4,28	<b>7,90 A++</b>	1,87(0,63-2,66)	935	9,00	1,34	1,68	2,35	4,03	9,40(4,20-10,60)	4,77	<b>4,70 A++</b>	1,97(0,81-2,87)	985	9,30		
20+25+42+42	1,24	1,56	2,60	2,60	8,00(3,00-9,20)	4,17	<b>7,90 A++</b>	1,92(0,57-2,80)	960	9,20	1,46	1,82	3,06	3,06	9,40(4,20-10,60)	4,75	<b>4,70 A++</b>	1,98(0,72-2,91)	990	9,30		
20+25+42+50	1,17	1,46	2,45	2,92	8,00(3,00-9,20)	4,28	<b>7,90 A++</b>	1,87(0,63-2,66)	935	9,00	1,37	1,72	2,88	3,43	9,40(4,20-10,60)	4,70	<b>4,70 A++</b>	2,00(0,81-2,86)	1000	9,40		
20+25+42+60	1,09	1,36	2,29	3,26	8,00(3,00-9,20)	4,28	<b>7,90 A++</b>	1,87(0,63-2,66)	935	9,00	1,28	1,60	2,69	3,83	9,40(4,20-10,60)	4,70	<b>4,70 A++</b>	2,00(0,81-2,86)	1000	9,40		
20+25+50+50	1,10	1,38	2,76	2,76	8,00(3,00-9,20)	4,23	<b>7,90 A++</b>	1,89(0,70-2,60)	945	9,00	1,30	1,62	3,24	3,24	9,40(4,20-10,60)	4,68	<b>4,70 A++</b>	2,01(0,94-2,89)	1005	9,40		
20+35+35+35	1,28	2,24	2,24	2,24	8,00(3,00-9,20)	4,17	<b>7,90 A++</b>	1,92(0,57-2,72)	960	9,20	1,51	2,63	2,63	2,63	9,40(4,20-10,60)	4,75	<b>4,70 A++</b>	1,98(0,75-2,90)	990	9,30		
20+35+35+42	1,21	2,12	2,12	2,55	8,00(3,00-9,20)	4,17	<b>7,90 A++</b>	1,92(0,57-2,72)	960	9,20	1,42	2,49	2,49	3,00	9,40(4,20-10,60)	4,77	<b>4,70 A++</b>	1,97(0,75-2,89)	985	9,30		
20+35+35+50	1,14	2,00	2,00	2,86	8,00(3,00-9,20)	4,28	<b>7,90 A++</b>	1,87(0,63-2,66)	935	9,00	1,34	2,35	2,35	3,36	9,40(4,20-10,60)	4,70	<b>4,70 A++</b>	2,00(0,84-2,85)	1000	9,40		
20+35+42+42	1,15	2,01	2,42	2,42	8,00(3,00-9,20)	4,17	<b>7,90 A++</b>	1,92(0,57-2,72)	960	9,20	1,35	2,37	2,84	2,84	9,40(4,20-10,60)	4,77	<b>4,70 A++</b>	1,97(0,76-2,88)	985	9,30		
20+35+42+50	1,09	1,90	2,29	2,72	8,00(3,00-9,20)	4,28	<b>7,90 A++</b>	1,87(0,63-2,66)	935	9,00	1,28	2,24	2,69	3,19	9,40(4,20-10,60)	4,72	<b>4,70 A++</b>	1,99(0,85-2,84)	995	9,40		
20+42+42+42	1,10	2,30	2,30	2,30	8,00(3,00-9,20)	4,28	<b>7,90 A++</b>	1,87(0,58-2,72)	935	9,00	1,30	2,70	2,70	2,70	9,40(4,20-10,60)	4,70	<b>4,70 A++</b>	2,00(0,76-2,87)	1000	9,40		
25+25+25+25	2,00	2,00	2,00	2,00	8,00(3,00-9,20)	4,04	<b>7,90 A++</b>	1,98(0,53-2,87)	990	9,50	2,35	2,35	2,35	2,35	9,40(4,20-10,60)	4,63	<b>4,70 A++</b>	2,03(0,69-2,99)	1015	9,50		
25+25+25+35	1,82	1,82	1,82	2,54	8,00(3,00-9,20)	4,17	<b>7,90 A++</b>	1,92(0,57-2,80)	960	9,20	2,14	2,14	2,14	2,98	9,40(4,20-10,60)	4,68	<b>4,70 A++</b>	2,01(0,71-2,96)	1005	9,40		
25+25+25+42	1,71	1,71	1,71	2,87	8,00(3,00-9,20)	4,17	<b>7,90 A++</b>	1,92(0,57-2,80)	960	9,20	2,01	2,01	2,01	3,37	9,40(4,20-10,60)	4,68	<b>4,70 A++</b>	2,01(0,72-2,95)	1005	9,40		
25+25+25+50	1,60	1,60	1,60	3,20	8,00(3,00-9,20)	4,28	<b>7,90 A++</b>	1,87(0,62-2,65)	935	9,00	1,88	1,88	1,88	3,76	9,40(4,20-10,60)	4,75	<b>4,70 A++</b>	1,98(0,80-2,89)	990	9,30		
25+25+25+60	1,48	1,48	1,48	3,56	8,00(3,00-9,20)	4,28	<b>7,90 A++</b>	1,87(0,62-2,65)	935	9,00	1,74	1,74	1,74	4,18	9,40(4,20-10,60)	4,75	<b>4,70 A++</b>	1,98(0,80-2,89)	990	9,30		
25+25+25+71	1,37	1,37	1,37	3,89	8,00(3,00-9,20)	4,28	<b>7,90 A++</b>	1,87(0,63-2,66)	935	9,00	1,61	1,61	1,61	4,57	9,40(4,20-10,60)	4,77	<b>4,70 A++</b>	1,97(0,80-2,88)	985	9,30		
25+25+35+35	1,67	1,67	2,33	2,33	8,00(3,00-9,20)	4,17	<b>7,90 A++</b>	1,92(0,57-2,80)	960	9,20	1,96	1,96	2,74	2,74	9,40(4,20-10,60)	4,70	<b>4,70 A++</b>	2,00(0,72-2,93)	1000	9,40		
25+25+35+42	1,57	1,57	2,20	2,66	8,00(3,00-9,20)	4,17	<b>7,90 A++</b>	1,92(0,57-2,80)	960	9,20	1,85	1,85	2,59	3,11	9,40(4,20-10,60)	4,72	<b>4,70 A++</b>	1,99(0,72-2,92)	995	9,40		
25+25+35+50	1,48	1,48	2,07	2,97	8,00(3,00-9,20)	4,28	<b>7,90 A++</b>	1,87(0,63-2,66)	935	9,00	1,74	1,74	2,44	3,48	9,40(4,20-10,60)	4,77	<b>4,70 A++</b>	1,97(0,81-2,87)	985	9,30		
25+25+35+60	1,38	1,38	1,93	3,31	8,00(3,00-9,20)	4,28	<b>7,90 A++</b>	1,87(0,63-2,66)	935	9,00	1,62	1,62	2,27	3,89	9,40(4,20-10,60)	4,77	<b>4,70 A++</b>	1,97(0,81-2,87)	985	9,30		
25+25+42+42	1,49	1,49	2,51	2,51	8,00(3,00-9,20)	4,17	<b>7,90 A++</b>	1,92(0,57-2,80)	960	9,20	1,75	1,75	2,95	2,95	9,40(4,20-10,60)	4,75	<b>4,70 A++</b>	1,98(0,72-2,91)	990	9,30		
25+25+42+50	1,41	1,41	2,37	2,81	8,00(3,00-9,20)	4,28	<b>7,90 A++</b>	1,87(0,63-2,66)	935	9,00	1,65	1,65	2,78	3,32	9,40(4,20-10,60)	4,70	<b>4,70 A++</b>	2,00(0,81-2,86)	1000	9,40		
25+35+35+35	1,55	2,15	2,15	2,15	8,00(3,00-9,20)	4,17	<b>7,90 A++</b>	1,92(0,57-2,72)	960	9,20	1,81	2,53	2,53	2,53	9,40(4,20-10,60)	4,75	<b>4,70 A++</b>	1,98(0,75-2,90)	990	9,30		
25+35+35+42	1,46	2,04	2,04	2,46	8,00(3,00-9,20)	4,17	<b>7,90 A++</b>	1,92(0,57-2,72)	960	9,20	1,72	2,40	2,40	2,88	9,40(4,20-10,60)	4,77	<b>4,70 A++</b>	1,97(0,75-2,89)	985	9,30		
25+35+35+50	1,38	1,93	1,93	2,76	8,00(3,00-9,20)	4,28	<b>7,90 A++</b>	1,87(0,63-2,66)	935	9,00	1,62	2,27	2,27	3,24	9,40(4,20-10,60)	4,70	<b>4,70 A++</b>	2,00(0,84-2,85)	1000	9,40		
25+35+42+42	1,39	1,95	2,33	2,33	8,00(3,00-9,20)	4,17	<b>7,90 A++</b>	1,92(0,57-2,72)	960	9,20	1,63	2,29	2,74	2,74	9,40(4,20-10,60)	4,77	<b>4,70 A++</b>	1,97(0,76-2,88)	985	9,30		
35+35+35+35	2,00	2,00	2,00	2,00	8,00(3,00-9,20)	4,28	<b>7,90 A++</b>	1,87(0,58-2,72)	935	9,00	2,35	2,35	2,35	2,35	9,40(4,20-10,60)	4,70	<b>4,70 A++</b>	2,00(0,76-2,87)	1000	9,40		
35+35+35+42	1,90	1,90	1,90	2,30	8,00(3,00-9,20)	4,28	<b>7,90 A++</b>	1,87(0,58-2,72)	935	9,00	2,24	2,24	2,24	2,68	9,40(4,20-10,60)	4,70	<b>4,70 A++</b>	2,00(0,76-2,86)	1000	9,40		

1) Energy Label Scale from A+++ to D.





# Free Multi R32 combinations table

## Free Multi 5x1 CU-5Z90TBE. Minimum capacity connected: 4,5 kW. Maximum capacity connected: 18,3 kW • R32 refrigerant

Indoor unit capacity	Cooling capacity (kW). Rooms					EER	SEER <sup>1)</sup>	Input power A.E.C. Current rating			Heating capacity (kW). Rooms					COP	SCOP <sup>1)</sup>	Input power A.E.C. Current rating				
	A	B	C	D	E			Total (Min - Max)	W/W	kW	kWh	230V	A	B	C			D	E	Total (Min - Max)	W/W	kW
16+60+71	0,98	3,67	4,35			9,00(3,00-10,70)	4,15	<b>7,20 A++</b>	2,17(0,40-2,87)	1085	10,40	1,13	4,24	5,03			10,40(2,70-14,10)	4,81	<b>4,20 A+</b>	2,16(0,31-3,65)	1080	10,20
16+71+71	0,92	4,04	4,04			9,00(3,00-10,70)	4,27	<b>7,20 A++</b>	2,11(0,40-2,81)	1055	10,10	1,06	4,67	4,67			10,40(2,70-14,40)	4,75	<b>4,20 A+</b>	2,19(0,32-3,75)	1095	10,30
20+20+20	2,00	2,00	2,00			6,00(2,90-8,50)	4,32	<b>7,20 A++</b>	1,39(0,31-2,55)	695	6,70	2,86	2,86	2,86			8,58(2,70-12,30)	4,33	<b>4,10 A+</b>	1,98(0,23-3,35)	990	9,30
20+20+25	2,00	2,00	2,50			6,50(2,90-8,50)	4,06	<b>7,20 A++</b>	1,60(0,31-2,55)	800	7,70	2,77	2,77	3,46			9,00(2,70-12,30)	4,25	<b>4,10 A+</b>	2,12(0,23-3,35)	1060	10,00
20+20+35	2,00	2,00	3,50			7,50(2,90-8,50)	3,85	<b>7,20 A++</b>	1,95(0,34-2,49)	975	9,30	2,61	2,61	4,58			9,80(2,70-12,30)	4,12	<b>4,10 A+</b>	2,38(0,23-3,26)	1190	11,20
20+20+42	2,00	2,00	4,20			8,20(2,90-8,70)	3,57	<b>7,20 A++</b>	2,30(0,34-2,54)	1150	11,00	2,54	2,54	5,32			10,40(2,70-12,90)	4,24	<b>4,10 A+</b>	2,45(0,23-3,53)	1225	11,50
20+20+50	2,00	2,00	5,00			9,00(2,90-9,60)	3,73	<b>7,20 A++</b>	2,41(0,34-2,62)	1205	11,50	2,31	2,31	5,78			10,40(2,70-13,60)	4,54	<b>4,20 A+</b>	2,29(0,25-3,62)	1145	10,80
20+20+60	1,80	1,80	5,00			9,00(2,90-10,70)	3,73	<b>7,20 A++</b>	2,41(0,34-3,41)	1205	11,50	2,08	2,08	6,24			10,40(2,70-13,60)	4,54	<b>4,20 A+</b>	2,29(0,25-3,62)	1145	10,80
20+20+71	1,62	1,62	5,76			9,00(2,90-10,70)	3,83	<b>7,20 A++</b>	2,35(0,34-3,27)	1175	11,20	1,87	1,87	6,66			10,40(2,70-13,80)	4,56	<b>4,20 A+</b>	2,28(0,25-3,71)	1140	10,70
20+25+25	2,00	2,50	2,50			7,00(2,90-8,50)	3,93	<b>7,20 A++</b>	1,78(0,31-2,55)	890	8,50	2,68	3,36	3,36			9,40(2,70-12,30)	4,16	<b>4,10 A+</b>	2,26(0,23-3,35)	1130	10,60
20+25+35	2,00	2,50	3,50			8,00(2,90-8,50)	3,67	<b>7,20 A++</b>	2,18(0,34-2,49)	1090	10,40	2,55	3,19	4,46			10,20(2,70-12,90)	4,16	<b>4,10 A+</b>	2,45(0,23-3,54)	1225	11,50
20+25+42	2,00	2,50	4,20			8,70(2,90-9,60)	3,43	<b>7,20 A++</b>	2,54(0,34-3,00)	1270	12,20	2,39	2,99	5,02			10,40(2,70-13,60)	4,24	<b>4,20 A+</b>	2,45(0,23-3,87)	1225	11,50
20+25+50	1,89	2,37	4,74			9,00(2,90-10,10)	3,73	<b>7,20 A++</b>	2,41(0,34-2,94)	1205	11,50	2,19	2,74	5,47			10,40(2,70-13,60)	4,54	<b>4,20 A+</b>	2,29(0,25-3,62)	1145	10,80
20+25+60	1,71	2,14	5,15			9,00(2,90-10,70)	3,73	<b>7,20 A++</b>	2,41(0,34-3,41)	1205	11,50	1,98	2,48	5,94			10,40(2,70-13,80)	4,54	<b>4,20 A+</b>	2,29(0,25-3,73)	1145	10,80
20+25+71	1,55	1,94	5,51			9,00(2,90-10,70)	3,83	<b>7,20 A++</b>	2,35(0,34-3,27)	1175	11,20	1,79	2,24	6,37			10,40(2,70-13,80)	4,56	<b>4,20 A+</b>	2,28(0,25-3,71)	1140	10,70
20+35+35	2,00	3,50	3,50			9,00(2,90-9,60)	3,38	<b>7,20 A++</b>	2,66(0,34-2,93)	1330	12,70	2,32	4,04	4,04			10,40(2,70-13,60)	4,28	<b>4,20 A+</b>	2,43(0,24-3,85)	1215	11,40
20+35+42	1,85	3,25	3,90			9,00(2,90-10,70)	3,38	<b>7,20 A++</b>	2,66(0,34-3,91)	1330	12,70	2,14	3,75	4,51			10,40(2,70-13,60)	4,30	<b>4,20 A+</b>	2,42(0,24-3,78)	1210	11,40
20+35+50	1,71	3,00	4,29			9,00(2,90-10,70)	3,83	<b>7,20 A++</b>	2,35(0,34-3,34)	1175	11,20	1,98	3,47	4,95			10,40(2,70-13,80)	4,60	<b>4,20 A+</b>	2,26(0,27-3,70)	1130	10,60
20+35+60	1,56	2,74	4,07			9,00(2,90-10,70)	3,83	<b>7,20 A++</b>	2,35(0,34-3,34)	1175	11,20	1,81	3,17	5,42			10,40(2,70-13,80)	4,60	<b>4,20 A+</b>	2,26(0,27-3,70)	1130	10,60
20+35+71	1,43	2,50	5,07			9,00(2,90-10,70)	3,95	<b>7,20 A++</b>	2,28(0,37-3,20)	1140	10,90	1,65	2,89	5,86			10,40(2,70-13,80)	4,62	<b>4,20 A+</b>	2,25(0,27-3,68)	1125	10,60
20+42+42	1,74	3,63	3,63			9,00(2,90-10,70)	3,46	<b>7,20 A++</b>	2,60(0,34-3,91)	1300	12,40	2,00	4,20	4,20			10,40(2,70-13,60)	4,32	<b>4,20 A+</b>	2,41(0,24-3,77)	1205	11,30
20+42+50	1,60	3,38	4,02			9,00(2,90-10,70)	3,83	<b>7,20 A++</b>	2,35(0,34-3,27)	1175	11,20	1,86	3,90	4,64			10,40(2,70-13,80)	4,60	<b>4,20 A+</b>	2,26(0,27-3,68)	1130	10,60
20+42+60	1,47	3,10	4,43			9,00(2,90-10,70)	3,83	<b>7,20 A++</b>	2,35(0,34-3,27)	1175	11,20	1,70	3,58	5,12			10,40(2,70-13,80)	4,60	<b>4,20 A+</b>	2,26(0,27-3,68)	1130	10,60
20+42+71	1,35	2,84	4,81			9,00(2,90-10,70)	3,95	<b>7,20 A++</b>	2,28(0,37-3,20)	1140	10,90	1,56	3,28	5,56			10,40(2,70-14,10)	4,64	<b>4,20 A+</b>	2,24(0,27-3,78)	1120	10,50
20+50+50	1,50	3,75	3,75			9,00(2,90-10,70)	4,17	<b>7,20 A++</b>	2,16(0,37-2,94)	1080	10,30	1,74	4,33	4,33			10,40(2,70-13,80)	4,81	<b>4,20 A+</b>	2,16(0,31-3,48)	1080	10,20
20+50+60	1,38	3,46	4,16			9,00(2,90-10,70)	4,17	<b>7,20 A++</b>	2,16(0,37-2,94)	1080	10,30	1,60	4,00	4,80			10,40(2,70-14,10)	4,81	<b>4,20 A+</b>	2,16(0,31-3,65)	1080	10,20
20+50+71	1,28	3,19	4,53			9,00(3,00-10,70)	4,15	<b>7,20 A++</b>	2,17(0,40-2,87)	1085	10,40	1,48	3,69	5,23			10,40(2,70-14,10)	4,75	<b>4,20 A+</b>	2,19(0,32-3,64)	1095	10,30
20+60+60	1,28	3,86	3,86			9,00(3,00-10,70)	4,17	<b>7,20 A++</b>	2,16(0,40-2,94)	1080	10,30	1,48	4,46	4,46			10,40(2,70-14,10)	4,81	<b>4,20 A+</b>	2,16(0,31-3,65)	1080	10,20
20+60+71	1,19	3,58	4,23			9,00(3,00-10,70)	4,15	<b>7,20 A++</b>	2,17(0,40-2,87)	1085	10,40	1,38	4,13	4,89			10,40(2,70-14,40)	4,75	<b>4,20 A+</b>	2,19(0,32-3,75)	1095	10,30
20+71+71	1,12	3,94	3,94			9,00(3,00-10,70)	4,27	<b>7,20 A++</b>	2,11(0,41-2,81)	1055	10,10	1,28	4,56	4,56			10,40(2,70-14,40)	4,77	<b>4,20 A+</b>	2,18(0,33-3,74)	1090	10,20
25+25+25	2,12	3,50	2,50			7,50(2,90-8,50)	3,73	<b>7,20 A++</b>	2,11(0,31-2,55)	1005	9,60	3,23	3,23	3,23			9,69(2,70-12,30)	4,02	<b>4,10 A+</b>	2,49(0,23-3,35)	1205	11,30
25+25+35	2,50	2,50	3,50			8,50(2,90-9,60)	3,41	<b>7,20 A++</b>	2,49(0,34-3,00)	1245	11,90	3,06	3,06	4,28			10,40(2,70-13,60)	4,23	<b>4,20 A+</b>	2,46(0,23-3,89)	1230	11,60
25+25+42	2,45	2,45	4,10			9,00(2,90-10,10)	3,30	<b>7,20 A++</b>	2,73(0,34-3,40)	1365	13,10	2,83	2,83	4,74			10,40(2,70-13,60)	4,24	<b>4,20 A+</b>	2,45(0,23-3,87)	1225	11,50
25+25+50	2,25	2,25	4,50			9,00(2,90-10,70)	3,73	<b>7,20 A++</b>	2,41(0,34-3,41)	1305	11,50	2,60	2,60	5,20			10,40(2,70-13,60)	4,54	<b>4,20 A+</b>	2,29(0,25-3,62)	1145	10,80
25+25+60	2,05	2,05	4,90			9,00(2,90-10,70)	3,73	<b>7,20 A++</b>	2,41(0,34-3,41)	1205	11,50	2,36	2,36	5,68			10,40(2,70-13,80)	4,54	<b>4,20 A+</b>	2,29(0,25-3,73)	1145	10,80
25+25+71	1,86	1,86	5,28			9,00(2,90-10,70)	3,83	<b>7,20 A++</b>	2,35(0,34-3,27)	1175	11,20	2,15	2,15	6,10			10,40(2,70-13,80)	4,56	<b>4,20 A+</b>	2,28(0,25-3,71)	1140	10,70
25+35+35	2,36	3,32	3,32			9,00(2,90-10,10)	3,38	<b>7,20 A++</b>	2,66(0,34-3,33)	1330	12,70	2,74	3,83	3,83			10,40(2,70-13,60)	4,28	<b>4,20 A+</b>	2,43(0,24-3,85)	1215	11,40
25+35+42	2,20	3,09	3,71			9,00(2,90-10,70)	3,38	<b>7,20 A++</b>	2,66(0,34-3,91)	1330	12,70	2,55	3,57	4,28			10,40(2,70-13,60)	4,30	<b>4,20 A+</b>	2,42(0,24-3,78)	1210	11,40
25+35+50	2,05	2,86	4,09			9,00(2,90-10,70)	3,83	<b>7,20 A++</b>	2,35(0,34-3,34)	1175	11,20	2,36	3,31	4,73			10,40(2,70-13,80)	4,60	<b>4,20 A+</b>	2,26(0,27-3,70)	1130	10,60
25+35+60	1,87	2,63	4,50			9,00(2,90-10,70)	3,83	<b>7,20 A++</b>	2,35(0,34-3,34)	1175	11,20	2,17	3,03	4,20			10,40(2,70-13,80)	4,60	<b>4,20 A+</b>	2,26(0,27-3,70)	1130	10,60
25+35+71	1,72	2,40	4,88			9,00(2,90-10,70)	3,95	<b>7,20 A++</b>	2,28(0,37-3,20)	1140	10,90	1,98	2,78	5,64			10,40(2,70-14,10)	4,62	<b>4,20 A+</b>	2,25(0,27-3,80)	1125	10,60
25+42+42	2,06	3,47	3,47			9,00(2,90-10,70)	3,46	<b>7,20 A++</b>	2,60(0,34-3,91)	1300	12,40	2,38	4,01	4,01			10,40(2,70-13,80)	4,32	<b>4,20 A+</b>	2,41(0,24-3,89)	1205	11,30
25+42+50	1,92	3,23	3,85			9,00(2,90-10,70)	3,83	<b>7,20 A++</b>	2,35(0,34-3,27)	1175	11,20	2,22	3,73	4,45			10,40(2,70-13,80)	4,60	<b>4,20 A+</b>	2,26(0,27-3,68)	1130	10,60
25+42+60	1,77	2,98	4,25			9,00(2,90-10,70)	3,83	<b>7,20 A++</b>	2,35(0,34-3,27)	1175	11,20	2,05	3,44	4,91			10,40(2,70-14,10)	4,60	<b>4,20 A+</b>	2,26(0,27-3,80)	1130	10,60
25+42+71	1,63	2,74	4,63			9,00(3,00-10,70)	3,95	<b>7,20 A++</b>	2,28(0,37-3,20)	1140	10,90	1,88	3,17	5,35			10,40(2,70-14,10)	4,64	<b>4,20 A+</b>	2,24(0,27-3,78)	1120	10,50
25+50+50	1,80	3,60	3,60			9,00(2,90-10,70)	4,17	<b>7,20 A++</b>	2,16(0,37-2,94)	1080	10,30	2,08	4,16	4,16			10,40(2,70-13,80)	4,81	<b>4,20 A+</b>	2,16(0,31-3,48)	1080	10,20
25+50+60	1,67	3,33	4,00			9,00(3,00-10,70)	4,17	<b>7,20 A++</b>	2,16(0,40-2,94)	1080	10,30	1,93	3,85	4,62			10,40(2,70-14,10)	4,81	<b>4,20 A+</b>	2,16(0,31-3,65)	1080	10,20
25+50+71	1,54																					



# Free Multi R32 combinations table

## Free Multi 5x1 CU-5Z90TBE. Minimum capacity connected: 4,5 kW. Maximum capacity connected: 18,3 kW • R32 refrigerant

Indoor unit capacity	Cooling capacity (kW). Rooms					EER	SEER <sup>1)</sup>	Input power			A.E.C.	Current	Heating capacity (kW). Rooms					COP	SCOP <sup>1)</sup>	Input power			A.E.C.	Current				
	A	B	C	D	E			Total (Min - Max)	W/W	kW			A	B	C	D	E			Total (Min - Max)	W/W	kW						
										kWh			230V													kWh	230V	
16+25+50+60	0,95	1,49	2,98	3,58		9,00	(3,00 - 11,00)	4,07	<b>8,00 A++</b>	2,21	(0,49 - 3,12)	1105	10,60	1,10	1,72	3,44	4,14	10,40	(3,40 - 14,40)	4,84	<b>4,40 A+</b>	2,15	(0,50 - 3,56)	1075	10,10			
16+25+50+71	0,89	1,39	2,78	3,94		9,00	(3,00 - 11,20)	4,07	<b>8,00 A++</b>	2,21	(0,52 - 3,20)	1105	10,60	1,03	1,60	3,21	4,56	10,40	(3,40 - 14,40)	4,84	<b>4,40 A+</b>	2,15	(0,51 - 3,60)	1075	10,10			
16+25+60+60	0,89	1,41	3,35	3,35		9,00	(3,00 - 11,20)	4,07	<b>8,00 A++</b>	2,21	(0,49 - 3,19)	1105	10,60	1,03	1,61	3,88	3,88	10,40	(3,40 - 14,40)	4,84	<b>4,40 A+</b>	2,15	(0,50 - 3,56)	1075	10,10			
16+25+60+71	0,83	1,31	3,14	3,72		9,00	(3,00 - 11,20)	4,07	<b>8,00 A++</b>	2,21	(0,52 - 3,20)	1105	10,60	0,97	1,51	3,63	4,29	10,40	(3,40 - 14,40)	4,84	<b>4,40 A+</b>	2,15	(0,51 - 3,60)	1075	10,10			
16+25+71+71	0,79	1,23	3,49	3,49		9,00	(3,00 - 11,20)	4,17	<b>8,00 A++</b>	2,16	(0,53 - 3,20)	1080	10,30	0,91	1,43	4,03	4,03	10,40	(3,40 - 14,40)	4,77	<b>4,40 A+</b>	2,18	(0,52 - 3,59)	1090	10,20			
16+35+35+35	1,20	2,60	2,60	2,60		9,00	(2,90 - 10,80)	3,90	<b>8,00 A++</b>	2,31	(0,38 - 3,33)	1155	11,10	1,37	3,01	3,01	3,01	10,40	(3,40 - 14,20)	4,84	<b>4,40 A+</b>	2,15	(0,37 - 3,64)	1075	10,10			
16+35+35+42	1,13	2,46	2,46	2,95		9,00	(2,90 - 10,80)	3,90	<b>8,00 A++</b>	2,31	(0,40 - 3,33)	1155	11,10	1,30	2,84	2,84	3,42	10,40	(3,40 - 14,40)	4,75	<b>4,40 A+</b>	2,19	(0,37 - 3,75)	1095	10,30			
16+35+35+50	1,05	2,32	2,32	3,31		9,00	(2,90 - 10,80)	4,09	<b>8,00 A++</b>	2,20	(0,44 - 3,11)	1100	10,50	1,22	2,68	2,68	3,82	10,40	(3,40 - 14,40)	4,81	<b>4,40 A+</b>	2,16	(0,43 - 3,61)	1080	10,20			
16+35+35+60	0,98	2,16	2,16	3,70		9,00	(3,00 - 11,00)	4,09	<b>8,00 A++</b>	2,20	(0,44 - 3,26)	1100	10,50	1,14	2,49	2,49	4,28	10,40	(3,40 - 14,40)	4,81	<b>4,40 A+</b>	2,16	(0,43 - 3,61)	1080	10,20			
16+35+35+71	0,91	2,01	2,01	4,07		9,00	(3,00 - 11,00)	4,09	<b>8,00 A++</b>	2,20	(0,47 - 3,19)	1100	10,50	1,06	2,32	2,32	4,70	10,40	(3,40 - 14,40)	4,84	<b>4,40 A+</b>	2,15	(0,45 - 3,65)	1075	10,10			
16+35+42+42	1,07	2,33	2,80	2,80		9,00	(2,90 - 10,80)	3,90	<b>8,00 A++</b>	2,31	(0,40 - 3,33)	1155	11,10	1,22	2,70	3,24	3,24	10,40	(3,40 - 14,40)	4,77	<b>4,40 A+</b>	2,18	(0,37 - 3,73)	1090	10,20			
16+35+42+50	1,01	2,20	2,64	3,15		9,00	(3,00 - 11,00)	4,09	<b>8,00 A++</b>	2,20	(0,44 - 3,26)	1100	10,50	1,16	2,55	3,05	3,64	10,40	(3,40 - 14,40)	4,84	<b>4,40 A+</b>	2,15	(0,45 - 3,65)	1075	10,10			
16+35+42+60	0,94	2,06	2,47	3,53		9,00	(3,00 - 11,00)	4,09	<b>8,00 A++</b>	2,20	(0,44 - 3,26)	1100	10,50	1,09	2,38	2,85	4,08	10,40	(3,40 - 14,40)	4,84	<b>4,40 A+</b>	2,15	(0,45 - 3,65)	1075	10,10			
16+35+42+71	0,88	1,92	2,30	3,90		9,00	(3,00 - 11,20)	4,09	<b>8,00 A++</b>	2,20	(0,47 - 3,33)	1100	10,50	1,01	2,22	2,66	4,51	10,40	(3,40 - 14,40)	4,86	<b>4,40 A+</b>	2,14	(0,45 - 3,64)	1070	10,10			
16+35+50+50	0,95	2,09	2,98	2,98		9,00	(3,00 - 11,00)	4,07	<b>8,00 A++</b>	2,21	(0,52 - 3,05)	1105	10,60	1,10	2,42	3,44	3,44	10,40	(3,40 - 14,40)	4,77	<b>4,40 A+</b>	2,18	(0,52 - 3,59)	1090	10,20			
16+35+50+60	0,89	1,96	2,80	3,35		9,00	(3,00 - 11,20)	4,07	<b>8,00 A++</b>	2,21	(0,52 - 3,20)	1105	10,60	1,03	2,26	3,23	3,88	10,40	(3,40 - 14,40)	4,77	<b>4,40 A+</b>	2,18	(0,52 - 3,59)	1090	10,20			
16+35+50+71	0,83	1,83	2,62	3,72		9,00	(3,00 - 11,20)	4,19	<b>8,00 A++</b>	2,15	(0,52 - 3,20)	1075	10,30	0,97	2,12	3,02	4,29	10,40	(3,40 - 14,40)	4,77	<b>4,40 A+</b>	2,18	(0,54 - 3,57)	1090	10,20			
16+35+60+60	0,84	1,84	3,16	3,16		9,00	(3,00 - 11,20)	4,07	<b>8,00 A++</b>	2,21	(0,52 - 3,20)	1105	10,60	0,97	2,13	3,65	3,65	10,40	(3,40 - 14,40)	4,77	<b>4,40 A+</b>	2,18	(0,52 - 3,59)	1090	10,20			
16+35+60+71	0,79	1,73	2,97	3,51		9,00	(3,00 - 11,20)	4,19	<b>8,00 A++</b>	2,15	(0,52 - 3,20)	1075	10,30	0,91	2,00	3,43	4,06	10,40	(3,40 - 14,40)	4,77	<b>4,40 A+</b>	2,18	(0,54 - 3,57)	1090	10,20			
16+42+42+42	1,02	2,66	2,66	2,66		9,00	(3,00 - 11,00)	3,90	<b>8,00 A++</b>	2,31	(0,40 - 3,48)	1155	11,10	1,16	3,08	3,08	3,08	10,40	(3,40 - 14,40)	4,79	<b>4,40 A+</b>	2,17	(0,39 - 3,72)	1085	10,20			
16+42+42+50	0,96	2,52	2,52	3,00		9,00	(3,00 - 11,00)	4,09	<b>8,00 A++</b>	2,20	(0,44 - 3,19)	1100	10,50	1,11	2,91	2,91	3,47	10,40	(3,40 - 14,40)	4,84	<b>4,40 A+</b>	2,15	(0,45 - 3,64)	1075	10,10			
16+42+42+60	0,90	2,36	2,36	3,38		9,00	(3,00 - 11,20)	4,09	<b>8,00 A++</b>	2,20	(0,44 - 3,33)	1100	10,50	1,04	2,73	2,73	3,90	10,40	(3,40 - 14,40)	4,84	<b>4,40 A+</b>	2,15	(0,45 - 3,64)	1075	10,10			
16+42+42+71	0,84	2,21	2,21	3,74		9,00	(3,00 - 11,20)	4,09	<b>8,00 A++</b>	2,20	(0,48 - 3,34)	1100	10,50	0,97	2,55	3,55	4,33	10,40	(3,40 - 14,40)	4,86	<b>4,40 A+</b>	2,14	(0,46 - 3,63)	1070	10,10			
16+42+50+50	0,91	2,29	2,85	2,85		9,00	(3,00 - 11,20)	4,07	<b>8,00 A++</b>	2,21	(0,52 - 3,20)	1105	10,60	1,05	2,77	3,29	3,29	10,40	(3,40 - 14,40)	4,77	<b>4,40 A+</b>	2,18	(0,53 - 3,58)	1090	10,20			
16+42+50+60	0,86	2,25	2,68	3,21		9,00	(3,00 - 11,20)	4,07	<b>8,00 A++</b>	2,21	(0,52 - 3,20)	1105	10,60	0,99	2,60	3,10	3,71	10,40	(3,40 - 14,40)	4,77	<b>4,40 A+</b>	2,18	(0,53 - 3,58)	1090	10,20			
16+42+50+71	0,80	2,11	2,51	3,58		9,00	(3,00 - 11,20)	4,17	<b>8,00 A++</b>	2,16	(0,53 - 3,20)	1080	10,30	0,93	2,44	2,91	4,12	10,40	(3,40 - 14,40)	4,79	<b>4,40 A+</b>	2,17	(0,54 - 3,56)	1085	10,20			
16+42+60+60	0,81	2,13	3,03	3,03		9,00	(3,00 - 11,20)	4,07	<b>8,00 A++</b>	2,21	(0,52 - 3,20)	1105	10,60	0,93	2,45	3,51	3,51	10,40	(3,40 - 14,40)	4,77	<b>4,40 A+</b>	2,18	(0,53 - 3,58)	1090	10,20			
16+50+50+50	0,87	2,71	2,71	2,71		9,00	(3,00 - 11,20)	4,15	<b>8,00 A++</b>	2,17	(0,57 - 3,14)	1085	10,40	1,01	3,13	3,13	3,13	10,40	(3,40 - 14,40)	4,66	<b>4,40 A+</b>	2,20	(0,63 - 3,58)	1115	10,50			
16+50+50+60	0,81	2,56	2,56	3,07		9,00	(3,00 - 11,20)	4,15	<b>8,00 A++</b>	2,17	(0,57 - 3,14)	1085	10,40	0,95	2,95	2,95	3,55	10,40	(3,40 - 14,40)	4,66	<b>4,40 A+</b>	2,23	(0,63 - 3,58)	1115	10,50			
20+20+20+20	2,00	2,00	2,00	2,00		8,00	(2,90 - 10,60)	4,06	<b>8,00 A++</b>	1,97	(0,37 - 3,40)	985	9,40	2,60	2,60	2,60	2,60	10,40	(3,40 - 14,20)	4,71	<b>4,20 A+</b>	2,21	(0,34 - 3,79)	1105	10,40			
20+20+20+25	2,00	2,00	2,00	2,50		8,50	(2,90 - 10,60)	3,95	<b>8,00 A++</b>	2,15	(0,37 - 3,40)	1075	10,30	2,45	2,45	2,45	3,05	10,40	(3,40 - 14,20)	4,71	<b>4,20 A+</b>	2,21	(0,34 - 3,79)	1105	10,40			
20+20+20+35	1,89	1,89	1,89	3,33		9,00	(2,90 - 10,60)	3,78	<b>8,00 A++</b>	2,38	(0,37 - 3,33)	1190	11,40	2,19	2,19	2,19	3,83	10,40	(3,40 - 14,20)	4,75	<b>4,40 A+</b>	2,19	(0,35 - 3,76)	1095	10,30			
20+20+20+42	1,76	1,76	1,76	3,72		9,00	(2,90 - 10,60)	3,78	<b>8,00 A++</b>	2,38	(0,37 - 3,33)	1190	11,40	2,04	2,04	2,04	4,28	10,40	(3,40 - 14,20)	4,77	<b>4,40 A+</b>	2,18	(0,36 - 3,74)	1090	10,20			
20+20+20+50	1,64	1,64	1,64	4,08		9,00	(2,90 - 10,60)	4,00	<b>8,00 A++</b>	2,25	(0,41 - 3,04)	1125	10,80	1,89	1,89	1,89	4,73	10,40	(3,40 - 14,20)	4,86	<b>4,40 A+</b>	2,14	(0,42 - 3,60)	1070	10,10			
20+20+20+60	1,50	1,50	1,50	4,50		9,00	(2,90 - 10,60)	4,00	<b>8,00 A++</b>	2,25	(0,41 - 3,04)	1125	10,80	1,73	1,73	1,73	5,21	10,40	(3,40 - 14,20)	4,86	<b>4,40 A+</b>	2,14	(0,42 - 3,60)	1070	10,10			
20+20+20+71	1,37	1,37	1,37	4,89		9,00	(2,90 - 10,80)	4,09	<b>8,00 A++</b>	2,20	(0,44 - 3,11)	1100	10,50	1,59	1,59	1,59	5,63	10,40	(3,40 - 14,40)	4,88	<b>4,40 A+</b>	2,13	(0,42 - 3,64)	1065	10,00			
20+20+25+25	2,00	2,00	2,50	2,50		9,00	(2,90 - 10,60)	3,78	<b>8,00 A++</b>	2,38	(0,37 - 3,40)	1190	11,40	2,31	2,31	2,89	2,89	10,40	(3,40 - 14,20)	4,71	<b>4,20 A+</b>	2,21	(0,34 - 3,79)	1105	10,40			
20+20+25+35	1,80	1,80	2,25	3,15		9,00	(2,90 - 10,60)	3,78	<b>8,00 A++</b>	2,38	(0,37 - 3,33)	1190	11,40	2,08	2,08	2,60	3,64	10,40	(3,40 - 14,20)	4,75	<b>4,40 A+</b>	2,19	(0,35 - 3,76)	1095	10,30			
20+20+25+42	1,68	1,68	2,10	3,54		9,00	(2,90 - 10,60)	3,78	<b>8,00 A++</b>	2,38	(0,37 - 3,33)	1190	11,40	1,94	1,94	2,43	4,09	10,40	(3,40 - 14,20)	4,77	<b>4,40 A+</b>	2,18	(0,36 - 3,74)	1090	10,20			
20+20+25+50	1,57	1,57	1,95	3,91		9,00	(2,90 - 10,60)	4,00	<b>8,00 A++</b>	2,25	(0,41 - 3,04)	1125	10,80	1,81	1,81	2,26	4,52	10,40	(3,40 - 14,20)	4,86	<b>4,40 A+</b>	2,14	(0,42 - 3,60)	1070	10,10			
20+20+25+60	1,44	1,44	1,80	4,32		9,00	(2,90 - 10,80)	4,00	<b>8,00 A++</b>	2,25	(0,41 - 3,18)	1125	10,80	1,66	1,66	2,08	5,00	10,40	(3,40 - 14,20)	4,86	<b>4,40 A+</b>	2,14	(0,42 - 3,60)	1070	10,10			
20+20+25+71	1,32	1,32	1,65	4,71		9,00	(2,90 - 10,80)	4,09	<b>8,00 A++</b>	2,20	(0,44 - 3,11)	1100	10,50	1,53	1,53	1,91	5,43	10,40	(3,40 -									

## Free Multi 5x1 CU-5Z90TBE. Minimum capacity connected: 4,5 kW. Maximum capacity connected: 18,3 kW • R32 refrigerant

Indoor unit capacity	Cooling capacity (kW). Rooms					EER	SEER <sup>1)</sup>	Input power rating			A.E.C.	Current	Heating capacity (kW). Rooms					COP	SCOP <sup>1)</sup>	Input power rating			A.E.C.	Current						
	A	B	C	D	E			Total (Min-Max)	W/W	kW			kWh	230V	A	B	C			D	E	Total (Min-Max)			W/W	kW	kWh	230V		
20+35+35+71	1,11	1,96	1,96	3,97	9,00	3,00	11,20	4,09	8,00	A++	2,20	0,47	-3,33	1100	10,50	1,29	2,26	2,26	4,59	10,40	3,40	-14,40	4,86	4,40	A+	2,14	0,45	-3,64	1070	10,10
20+35+42+42	1,29	2,27	2,72	2,72	9,00	2,90	-10,80	3,90	8,00	A++	2,31	0,40	-3,33	1155	11,10	1,50	2,62	3,14	3,14	10,40	3,40	-14,40	4,79	4,40	A+	2,17	0,39	-3,72	1085	10,20
20+35+42+50	1,22	2,14	2,57	3,07	9,00	3,00	-11,00	4,09	8,00	A++	2,20	0,44	-3,19	1100	10,50	1,41	2,48	2,97	3,54	10,40	3,40	-14,40	4,84	4,40	A+	2,15	0,45	-3,64	1075	10,10
20+35+42+60	1,14	2,01	2,41	3,44	9,00	3,00	-11,00	4,09	8,00	A++	2,20	0,44	-3,19	1100	10,50	1,32	2,32	2,78	3,98	10,40	3,40	-14,40	4,84	4,40	A+	2,15	0,45	-3,64	1075	10,10
20+35+42+71	1,07	1,88	2,25	3,80	9,00	3,00	-11,20	4,09	8,00	A++	2,20	0,48	-3,34	1100	10,50	1,24	2,17	2,60	4,39	10,40	3,40	-14,40	4,86	4,40	A+	2,14	0,46	-3,63	1070	10,10
20+35+50+50	1,16	2,04	2,90	2,90	9,00	3,00	-11,00	4,07	8,00	A++	2,21	0,52	-3,05	1105	10,60	1,34	2,36	3,35	3,35	10,40	3,40	-14,40	4,77	4,40	A+	2,18	0,53	-3,58	1090	10,20
20+35+50+60	1,09	1,91	2,73	3,27	9,00	3,00	-11,20	4,07	8,00	A++	2,21	0,52	-3,20	1105	10,60	1,26	2,21	3,15	3,78	10,40	3,40	-14,40	4,77	4,40	A+	2,18	0,53	-3,58	1090	10,20
20+35+50+71	1,02	1,79	2,56	3,63	9,00	3,00	-11,20	4,17	8,00	A++	2,16	0,53	-3,20	1080	10,30	1,18	2,07	2,95	4,20	10,40	3,40	-14,40	4,79	4,40	A+	2,17	0,54	-3,56	1085	10,20
20+35+60+60	1,02	1,80	3,09	3,09	9,00	3,00	-11,20	4,07	8,00	A++	2,21	0,52	-3,20	1105	10,60	1,19	2,07	3,57	3,57	10,40	3,40	-14,40	4,77	4,40	A+	2,18	0,53	-3,58	1090	10,20
20+42+42+42	1,23	2,59	2,59	2,59	9,00	3,00	-11,00	3,90	8,00	A++	2,31	0,40	-3,40	1155	11,10	1,43	2,99	2,99	2,99	10,40	3,40	-14,40	4,79	4,40	A+	2,17	0,39	-3,71	1085	10,20
20+42+42+50	1,17	2,45	2,45	2,93	9,00	3,00	-11,00	4,09	8,00	A++	2,20	0,45	-3,19	1100	10,50	1,35	2,84	2,84	3,37	10,40	3,40	-14,40	4,86	4,40	A+	2,14	0,45	-3,63	1070	10,10
20+42+42+60	1,10	2,30	2,30	3,30	9,00	3,00	-11,20	4,09	8,00	A++	2,20	0,45	-3,33	1100	10,50	1,27	2,66	2,66	3,81	10,40	3,40	-14,40	4,86	4,40	A+	2,14	0,45	-3,63	1070	10,10
20+42+42+71	1,03	2,16	2,16	3,65	9,00	3,00	-11,20	4,09	8,00	A++	2,20	0,48	-3,26	1100	10,50	1,19	2,50	2,50	4,21	10,40	3,40	-14,40	4,88	4,40	A+	2,13	0,46	-3,61	1065	10,00
20+42+50+50	1,11	2,33	2,78	2,78	9,00	3,00	-11,20	4,19	8,00	A++	2,15	0,52	-3,20	1075	10,30	1,28	2,70	3,21	3,21	10,40	3,40	-14,40	4,79	4,40	A+	2,17	0,54	-3,57	1085	10,20
20+42+50+60	1,04	2,20	2,62	3,14	9,00	3,00	-11,20	4,19	8,00	A++	2,15	0,52	-3,20	1075	10,30	1,21	2,54	3,02	3,63	10,40	3,40	-14,40	4,79	4,40	A+	2,17	0,54	-3,57	1085	10,20
20+42+50+71	0,98	2,07	2,46	3,49	9,00	3,00	-11,20	4,17	8,00	A++	2,16	0,53	-3,13	1080	10,30	1,14	2,39	2,84	4,03	10,40	3,40	-14,40	4,79	4,40	A+	2,17	0,55	-3,55	1085	10,20
20+42+60+60	0,98	2,08	2,97	2,97	9,00	3,00	-11,20	4,19	8,00	A++	2,15	0,52	-3,20	1075	10,30	1,14	2,40	3,43	3,43	10,40	3,40	-14,40	4,79	4,40	A+	2,17	0,54	-3,57	1085	10,20
20+50+50+50	1,05	2,65	2,65	2,65	9,00	3,00	-11,20	4,15	8,00	A++	2,17	0,58	-3,14	1085	10,40	1,22	3,06	3,06	3,06	10,40	3,40	-14,40	4,60	4,40	A+	2,26	0,63	-3,57	1130	10,60
20+50+50+60	1,00	2,50	2,50	3,00	9,00	3,00	-11,20	4,15	8,00	A++	2,17	0,58	-3,14	1085	10,40	1,16	2,89	2,89	3,46	10,40	3,40	-14,40	4,60	4,40	A+	2,26	0,63	-3,57	1130	10,60
25+25+25+25	2,25	2,25	2,25	2,25	9,00	2,90	-10,60	3,78	8,00	A++	2,38	0,37	-3,40	1190	11,40	2,60	2,60	2,60	2,60	10,40	3,40	-14,20	4,71	4,40	A+	2,21	0,34	-3,79	1105	10,40
25+25+25+35	2,05	2,05	2,05	2,85	9,00	2,90	-10,60	3,78	8,00	A++	2,38	0,37	-3,33	1190	11,40	2,36	2,36	2,36	3,30	10,40	3,40	-14,20	4,75	4,40	A+	2,19	0,35	-3,76	1095	10,30
25+25+25+42	1,92	1,92	1,92	3,24	9,00	2,90	-10,60	3,78	8,00	A++	2,38	0,37	-3,33	1190	11,40	2,22	2,22	2,22	3,74	10,40	3,40	-14,20	4,77	4,40	A+	2,18	0,36	-3,74	1090	10,20
25+25+25+50	1,80	1,80	1,80	3,60	9,00	2,90	-10,80	4,00	8,00	A++	2,25	0,41	-3,18	1125	10,80	2,08	2,08	2,08	4,16	10,40	3,40	-14,20	4,86	4,40	A+	2,14	0,42	-3,60	1070	10,10
25+25+25+60	1,67	1,67	1,67	3,99	9,00	2,90	-10,80	4,00	8,00	A++	2,25	0,41	-3,18	1125	10,80	1,93	1,93	1,93	4,61	10,40	3,40	-14,40	4,86	4,40	A+	2,14	0,42	-3,60	1070	10,10
25+25+25+71	1,54	1,54	1,54	4,38	9,00	3,00	-11,00	4,09	8,00	A++	2,20	0,44	-3,26	1100	10,50	1,78	1,78	1,78	5,06	10,40	3,40	-14,40	4,88	4,40	A+	2,13	0,42	-3,64	1065	10,00
25+25+35+35	1,87	1,87	2,63	2,63	9,00	2,90	-10,60	3,90	8,00	A++	2,31	0,37	-3,25	1155	11,10	2,17	2,17	3,03	3,03	10,40	3,40	-14,20	4,79	4,40	A+	2,17	0,37	-3,66	1085	10,20
25+25+35+42	1,77	1,77	2,48	2,98	9,00	2,90	-10,60	3,90	8,00	A++	2,31	0,37	-3,40	1155	11,10	2,05	2,05	2,87	3,43	10,40	3,40	-14,20	4,81	4,40	A+	2,16	0,37	-3,65	1080	10,20
25+25+35+50	1,67	1,67	2,33	3,33	9,00	2,90	-10,80	3,98	8,00	A++	2,26	0,44	-3,11	1130	10,80	1,93	1,93	2,70	3,84	10,40	3,40	-14,40	4,91	4,40	A+	2,12	0,42	-3,63	1060	10,00
25+25+35+60	1,55	1,55	2,17	3,73	9,00	3,00	-11,00	3,98	8,00	A++	2,26	0,44	-3,26	1130	10,80	1,79	1,79	2,51	4,31	10,40	3,40	-14,40	4,91	4,40	A+	2,12	0,42	-3,63	1060	10,00
25+25+35+71	1,44	1,44	2,02	4,10	9,00	3,00	-11,00	4,09	8,00	A++	2,20	0,44	-3,19	1100	10,50	1,67	1,67	2,33	4,73	10,40	3,40	-14,40	4,81	4,40	A+	2,16	0,43	-3,61	1080	10,20
25+25+42+42	1,68	1,68	2,82	2,82	9,00	2,90	-10,80	3,90	8,00	A++	2,31	0,37	-3,40	1155	11,10	1,94	1,94	3,26	3,26	10,40	3,40	-14,40	4,75	4,40	A+	2,19	0,37	-3,76	1095	10,30
25+25+42+50	1,58	1,58	2,66	3,18	9,00	3,00	-11,00	4,09	8,00	A++	2,20	0,44	-3,26	1100	10,50	1,83	1,83	3,08	3,66	10,40	3,40	-14,40	4,81	4,40	A+	2,16	0,43	-3,62	1080	10,20
25+25+42+60	1,48	1,48	2,49	3,55	9,00	3,00	-11,00	4,09	8,00	A++	2,20	0,44	-3,26	1100	10,50	1,71	1,71	2,87	4,11	10,40	3,40	-14,40	4,81	4,40	A+	2,16	0,43	-3,62	1080	10,20
25+25+42+71	1,38	1,38	2,32	3,92	9,00	3,00	-11,20	4,09	8,00	A++	2,20	0,45	-3,33	1100	10,50	1,60	1,60	2,68	4,52	10,40	3,40	-14,40	4,84	4,40	A+	2,15	0,44	-3,66	1075	10,10
25+25+50+50	1,50	1,50	3,00	3,00	9,00	3,00	-11,00	4,07	8,00	A++	2,21	0,49	-3,12	1105	10,60	1,73	1,73	3,47	3,47	10,40	3,40	-14,40	4,84	4,40	A+	2,15	0,51	-3,60	1075	10,10
25+25+50+60	1,41	1,41	2,80	3,38	9,00	3,00	-11,20	4,07	8,00	A++	2,21	0,49	-3,19	1105	10,60	1,63	1,63	3,25	3,89	10,40	3,40	-14,40	4,84	4,40	A+	2,15	0,51	-3,60	1075	10,10
25+25+50+71	1,32	1,32	2,62	3,74	9,00	3,00	-11,20	4,19	8,00	A++	2,15	0,52	-3,20	1075	10,30	1,52	1,52	3,04	4,32	10,40	3,40	-14,40	4,77	4,40	A+	2,18	0,52	-3,59	1090	10,20
25+25+60+60	1,32	1,32	3,18	3,18	9,00	3,00	-11,20	4,07	8,00	A++	2,21	0,49	-3,19	1105	10,60	1,53	1,53	3,67	3,67	10,40	3,40	-14,40	4,84	4,40	A+	2,15	0,51	-3,60	1075	10,10
25+25+60+71	1,24	1,24	2,98	3,54	9,00	3,00	-11,20	4,19	8,00	A++	2,15	0,52	-3,20	1075	10,30	1,44	1,44	3,45	4,07	10,40	3,40	-14,40	4,77	4,40	A+	2,18	0,52	-3,59	1090	10,20
25+35+35+35	1,74	2,42	2,42	2,42	9,00	2,90	-10,80	3,90	8,00	A++	2,31	0,40	-3,33	1155	11,10	2,00	2,80	2,80	2,80	10,40	3,40	-14,40	4,75	4,40	A+	2,19	0,37	-3,75	1095	10,30
25+35+35+42	1,64	2,30	2,30	2,76	9,00	2,90	-10,80	3,90	8,00	A++	2,31	0,40	-3,33	1155	11,10	1,90	2,66	2,66	3,18	10,40	3,40	-14,40	4,77	4,40	A+	2,18	0,37	-3,73	1090	10,20
25+35+35+50	1,																													

# Free Multi R32 combinations table

## Free Multi 5x1 CU-5Z90TBE. Minimum capacity connected: 4,5 kW. Maximum capacity connected: 18,3 kW • R32 refrigerant

Indoor unit capacity	Cooling capacity (kW). Rooms					EER	SEER <sup>1)</sup>	Input power A.E.C. Current			Heating capacity (kW). Rooms					COP	SCOP <sup>1)</sup>	Input power A.E.C. Current						
	A	B	C	D	E			Total (Min - Max)	W/W	kW	kWh	230V	A	B	C			D	E	Total (Min - Max)	W/W	kW	kWh	230V
16+16+16+16+16+42	1,36	1,36	1,36	1,36	3,56	9,00(2,90-11,50)	4,09	<b>8,50 A+++</b>	2,20(0,45-3,49)	1100	10,50	1,57	1,57	1,57	1,57	4,12	10,40(3,40-14,50)	4,86	<b>4,68 A++</b>	2,14(0,46-3,67)	1070	10,10		
16+16+16+16+50	1,26	1,26	1,26	1,26	3,96	9,00(2,90-11,50)	4,17	<b>8,50 A+++</b>	2,16(0,53-3,35)	1080	10,30	1,46	1,46	1,46	1,46	4,56	10,40(3,40-14,50)	4,79	<b>4,68 A++</b>	2,17(0,54-3,61)	1085	10,20		
16+16+16+16+60	1,16	1,16	1,16	1,16	4,36	9,00(2,90-11,50)	4,17	<b>8,50 A+++</b>	2,16(0,53-3,35)	1080	10,30	1,34	1,34	1,34	1,34	5,04	10,40(3,40-14,50)	4,79	<b>4,68 A++</b>	2,17(0,54-3,61)	1085	10,20		
16+16+16+16+71	1,07	1,07	1,07	1,07	4,72	9,00(2,90-11,50)	4,17	<b>8,50 A+++</b>	2,16(0,54-3,28)	1080	10,30	1,23	1,23	1,23	1,23	5,48	10,40(3,40-14,50)	4,71	<b>4,68 A++</b>	2,21(0,56-3,60)	1105	10,40		
16+16+16+20+20	1,60	1,60	1,60	2,00	2,00	8,80(2,90-11,50)	4,11	<b>8,50 A+++</b>	2,14(0,45-3,48)	1070	10,20	1,89	1,89	1,89	2,36	2,36	10,39(3,40-14,50)	4,83	<b>4,60 A++</b>	2,15(0,45-3,65)	1075	10,10		
16+16+16+20+25	1,55	1,55	1,55	1,94	2,41	9,00(2,90-11,50)	4,09	<b>8,50 A+++</b>	2,20(0,45-3,48)	1100	10,50	1,79	1,79	1,79	2,24	2,79	10,40(3,40-14,50)	4,84	<b>4,68 A++</b>	2,15(0,45-3,65)	1075	10,10		
16+16+16+20+35	1,40	1,40	1,40	1,75	3,05	9,00(2,90-11,50)	4,09	<b>8,50 A+++</b>	2,20(0,45-3,49)	1100	10,50	1,62	1,62	1,62	2,02	3,52	10,40(3,40-14,50)	4,86	<b>4,68 A++</b>	2,14(0,46-3,67)	1070	10,10		
16+16+16+20+42	1,31	1,31	1,31	1,64	3,43	9,00(2,90-11,50)	4,09	<b>8,50 A+++</b>	2,20(0,48-3,49)	1100	10,50	1,51	1,51	1,51	1,89	3,98	10,40(3,40-14,50)	4,88	<b>4,68 A++</b>	2,13(0,47-3,66)	1065	10,00		
16+16+16+20+50	1,22	1,22	1,22	1,53	3,81	9,00(2,90-11,50)	4,17	<b>8,50 A+++</b>	2,16(0,53-3,35)	1080	10,30	1,41	1,41	1,41	1,76	4,41	10,40(3,40-14,50)	4,79	<b>4,68 A++</b>	2,17(0,56-3,60)	1085	10,20		
16+16+16+20+60	1,13	1,13	1,13	1,41	4,20	9,00(2,90-11,50)	4,17	<b>8,50 A+++</b>	2,16(0,53-3,35)	1080	10,30	1,30	1,30	1,30	1,63	4,87	10,40(3,40-14,50)	4,79	<b>4,68 A++</b>	2,17(0,56-3,60)	1085	10,20		
16+16+16+20+71	1,04	1,04	1,04	1,29	4,59	9,00(2,90-11,50)	4,15	<b>8,50 A+++</b>	2,17(0,54-3,28)	1085	10,40	1,20	1,20	1,20	1,50	5,30	10,40(3,40-14,50)	4,73	<b>4,68 A++</b>	2,20(0,57-3,59)	1100	10,30		
16+16+16+25+25	1,47	1,47	1,47	2,29	2,29	8,99(2,90-11,50)	4,09	<b>8,50 A+++</b>	2,20(0,45-3,48)	1100	10,50	1,70	1,70	1,70	2,65	2,65	10,40(3,40-14,50)	4,84	<b>4,68 A++</b>	2,15(0,45-3,65)	1075	10,10		
16+16+16+25+35	1,33	1,33	1,33	2,08	2,93	9,00(2,90-11,50)	4,09	<b>8,50 A+++</b>	2,20(0,45-3,49)	1100	10,50	1,54	1,54	1,54	2,41	3,37	10,40(3,40-14,50)	4,86	<b>4,68 A++</b>	2,14(0,46-3,67)	1070	10,10		
16+16+16+25+42	1,25	1,25	1,25	1,96	3,29	9,00(2,90-11,50)	4,09	<b>8,50 A+++</b>	2,20(0,48-3,49)	1100	10,50	1,45	1,45	1,45	2,26	3,79	10,40(3,40-14,50)	4,88	<b>4,68 A++</b>	2,13(0,47-3,66)	1065	10,00		
16+16+16+25+50	1,17	1,17	1,17	1,83	3,66	9,00(2,90-11,50)	4,17	<b>8,50 A+++</b>	2,16(0,53-3,35)	1080	10,30	1,35	1,35	1,35	2,11	4,24	10,40(3,40-14,50)	4,79	<b>4,68 A++</b>	2,17(0,56-3,60)	1085	10,20		
16+16+16+25+60	1,08	1,08	1,08	1,69	4,07	9,00(2,90-11,50)	4,17	<b>8,50 A+++</b>	2,16(0,53-3,35)	1080	10,30	1,25	1,25	1,25	1,95	4,70	10,40(3,40-14,50)	4,79	<b>4,68 A++</b>	2,17(0,56-3,60)	1085	10,20		
16+16+16+25+71	1,00	1,00	1,00	1,56	4,44	9,00(2,90-11,50)	4,15	<b>8,50 A+++</b>	2,17(0,54-3,28)	1085	10,40	1,16	1,16	1,16	1,81	5,11	10,40(3,40-14,50)	4,73	<b>4,68 A++</b>	2,20(0,57-3,59)	1100	10,30		
16+16+16+35+35	1,22	1,22	1,22	2,67	2,67	9,00(2,90-11,50)	4,07	<b>8,50 A+++</b>	2,21(0,48-3,41)	1105	10,60	1,41	1,41	1,41	3,08	3,08	10,39(3,40-14,50)	4,81	<b>4,68 A++</b>	2,16(0,48-3,64)	1080	10,20		
16+16+16+35+42	1,15	1,15	1,15	2,52	3,03	9,00(2,90-11,50)	4,07	<b>8,50 A+++</b>	2,21(0,48-3,41)	1105	10,60	1,33	1,33	1,33	2,91	3,50	10,40(3,40-14,50)	4,81	<b>4,68 A++</b>	2,16(0,49-3,63)	1080	10,20		
16+16+16+35+50	1,08	1,08	1,08	2,37	3,39	9,00(2,90-11,50)	4,15	<b>8,50 A+++</b>	2,17(0,54-3,28)	1085	10,40	1,25	1,25	1,25	2,74	3,91	10,40(3,40-14,50)	4,73	<b>4,68 A++</b>	2,20(0,57-3,63)	1100	10,30		
16+16+16+35+60	1,01	1,01	1,01	2,20	3,77	9,00(2,90-11,50)	4,15	<b>8,50 A+++</b>	2,17(0,54-3,28)	1085	10,40	1,16	1,16	1,16	2,55	4,37	10,40(3,40-14,50)	4,73	<b>4,68 A++</b>	2,20(0,57-3,63)	1100	10,30		
16+16+16+35+71	0,94	0,94	0,94	2,05	4,13	9,00(2,90-11,50)	4,15	<b>8,50 A+++</b>	2,17(0,57-3,28)	1085	10,40	1,08	1,08	1,08	2,36	4,80	10,40(3,40-14,50)	4,73	<b>4,68 A++</b>	2,20(0,59-3,62)	1100	10,30		
16+16+16+42+42	1,09	1,09	1,09	2,86	2,86	8,99(2,90-11,50)	4,07	<b>8,50 A+++</b>	2,21(0,49-3,41)	1105	10,60	1,26	1,26	1,26	3,31	3,31	10,40(3,40-14,50)	4,84	<b>4,68 A++</b>	2,15(0,50-3,62)	1075	10,10		
16+16+16+42+50	1,03	1,03	1,03	2,70	3,21	9,00(2,90-11,50)	4,15	<b>8,50 A+++</b>	2,17(0,54-3,28)	1085	10,40	1,19	1,19	1,19	3,12	3,71	10,40(3,40-14,50)	4,73	<b>4,68 A++</b>	2,20(0,59-3,62)	1100	10,30		
16+16+16+42+60	0,96	0,96	0,96	2,52	3,60	9,00(2,90-11,50)	4,15	<b>8,50 A+++</b>	2,17(0,54-3,28)	1085	10,40	1,11	1,11	1,11	2,91	4,16	10,40(3,40-14,50)	4,73	<b>4,68 A++</b>	2,20(0,59-3,62)	1100	10,30		
16+16+16+42+71	0,89	0,89	0,89	2,35	3,98	9,00(2,90-11,50)	4,15	<b>8,50 A+++</b>	2,17(0,57-3,29)	1085	10,40	1,03	1,03	1,03	2,71	4,60	10,40(3,40-14,50)	4,66	<b>4,68 A++</b>	2,23(0,60-3,61)	1115	10,50		
16+16+16+50+50	0,97	0,97	0,97	3,04	3,05	9,00(2,90-11,50)	4,11	<b>8,50 A+++</b>	2,19(0,62-3,23)	1095	10,50	1,12	1,12	1,12	3,52	3,52	10,40(3,40-14,50)	4,54	<b>4,68 A++</b>	2,29(0,69-3,63)	1145	10,80		
16+16+16+50+60	0,91	0,91	0,91	2,85	3,42	9,00(2,90-11,50)	4,11	<b>8,50 A+++</b>	2,19(0,62-3,23)	1095	10,50	1,05	1,05	1,05	3,29	3,96	10,40(3,40-14,50)	4,54	<b>4,68 A++</b>	2,29(0,69-3,63)	1145	10,80		
16+16+16+50+71	0,85	0,85	0,85	2,66	3,79	9,00(2,90-11,50)	3,98	<b>8,50 A+++</b>	2,26(0,66-3,24)	1130	10,80	0,99	0,99	0,99	3,08	4,38	10,40(3,40-14,50)	4,54	<b>4,68 A++</b>	2,29(0,71-3,62)	1145	10,80		
16+16+16+60+60	0,86	0,86	0,86	3,21	3,21	9,00(2,90-11,50)	4,11	<b>8,50 A+++</b>	2,19(0,62-3,23)	1095	10,50	0,99	0,99	0,99	3,71	3,71	10,39(3,40-14,50)	4,54	<b>4,68 A++</b>	2,29(0,69-3,63)	1145	10,80		
16+16+16+60+71	0,80	0,80	0,80	3,02	3,58	9,00(2,90-11,50)	3,98	<b>8,50 A+++</b>	2,26(0,66-3,24)	1130	10,80	0,93	0,93	0,93	3,49	4,12	10,40(3,40-14,50)	4,54	<b>4,68 A++</b>	2,29(0,71-3,62)	1145	10,80		
16+16+20+20+20	1,56	1,56	1,56	1,96	1,96	9,00(2,90-11,50)	4,09	<b>8,50 A+++</b>	2,20(0,45-3,49)	1100	10,50	1,81	1,81	2,26	2,26	2,26	10,40(3,40-14,50)	4,86	<b>4,68 A++</b>	2,14(0,45-3,64)	1070	10,10		
16+16+20+20+25	1,48	1,48	1,48	1,86	2,32	9,00(2,90-11,50)	4,09	<b>8,50 A+++</b>	2,20(0,45-3,49)	1100	10,50	1,72	1,72	2,14	2,14	2,68	10,40(3,40-14,50)	4,86	<b>4,68 A++</b>	2,14(0,45-3,64)	1070	10,10		
16+16+20+20+35	1,35	1,35	1,35	1,68	2,94	9,00(2,90-11,50)	4,09	<b>8,50 A+++</b>	2,20(0,48-3,49)	1100	10,50	1,56	1,56	1,94	1,94	3,40	10,40(3,40-14,50)	4,88	<b>4,68 A++</b>	2,13(0,47-3,66)	1065	10,00		
16+16+20+20+42	1,26	1,26	1,26	1,58	3,32	9,00(2,90-11,50)	4,09	<b>8,50 A+++</b>	2,20(0,48-3,41)	1100	10,50	1,46	1,46	1,82	1,82	3,84	10,40(3,40-14,50)	4,79	<b>4,68 A++</b>	2,17(0,48-3,65)	1085	10,20		
16+16+20+20+50	1,18	1,18	1,18	1,48	3,68	9,00(2,90-11,50)	4,17	<b>8,50 A+++</b>	2,16(0,53-3,28)	1080	10,30	1,36	1,36	1,70	1,70	4,28	10,40(3,40-14,50)	4,73	<b>4,68 A++</b>	2,20(0,56-3,59)	1100	10,30		
16+16+20+20+60	1,09	1,09	1,09	1,36	4,10	9,00(2,90-11,50)	4,17	<b>8,50 A+++</b>	2,16(0,53-3,28)	1080	10,30	1,26	1,26	1,58	1,58	4,72	10,40(3,40-14,50)	4,73	<b>4,68 A++</b>	2,20(0,56-3,59)	1100	10,30		
16+16+20+20+71	1,01	1,01	1,01	1,26	4,46	9,00(2,90-11,50)	4,15	<b>8,50 A+++</b>	2,17(0,57-3,28)	1085	10,40	1,16	1,16	1,45	1,45	5,18	10,40(3,40-14,50)	4,73	<b>4,68 A++</b>	2,20(0,57-3,58)	1100	10,30		
16+16+20+25+25	1,41	1,41	1,76	2,21	2,21	9,00(2,90-11,50)	4,09	<b>8,50 A+++</b>	2,20(0,45-3,49)	1100	10,50	1,63	1,63	2,04	2,55	2,55	10,40(3,40-14,50)	4,86	<b>4,68 A++</b>	2,14(0,45-3,64)	1070	10,10		
16+16+20+25+35	1,29	1,29	1,61	2,01	2,80	9,00(2,90-11,50)	4,09	<b>8,50 A+++</b>	2,20(0,48-3,49)	1100	10,50	1,49	1,49	1,86	2,32	3,24	10,40(3,40-14,50)	4,88	<b>4,68 A++</b>	2,13(0,47-				

## Free Multi 5x1 CU-5Z90TBE. Minimum capacity connected: 4,5 kW. Maximum capacity connected: 18,3 kW • R32 refrigerant

Indoor unit capacity	Cooling capacity (kW). Rooms					EER	SEER <sup>1)</sup>	Input power rating			A.E.C.	Current	Heating capacity (kW). Rooms					COP	SCOP <sup>1)</sup>	Input power rating			A.E.C.	Current								
	A	B	C	D	E			Total (Min-Max)	W/W	kW			kWh	230V	A	B	C			D	E	Total (Min-Max)			W/W	kW	kWh	230V				
16+16+35+35+71	0,83	0,83	1,82	1,82	3,70	9,00	2,90	-11,50	4,13	8,50	A+++	2,18	0,58	-3,29	1090	10,40	0,96	0,96	2,10	2,10	4,28	10,40	3,40	-14,50	4,66	4,68	A++	2,23	0,62	-3,58	1115	10,50
16+16+35+42+42	0,95	0,95	2,10	2,50	2,50	9,00	2,90	-11,50	4,07	8,50	A+++	2,21	0,49	-3,34	1105	10,60	1,10	1,10	2,42	2,89	2,89	10,40	3,40	-14,50	4,77	4,68	A++	2,18	0,52	-3,64	1090	10,20
16+16+35+42+50	0,91	0,91	1,98	2,38	2,82	9,00	2,90	-11,50	4,15	8,50	A+++	2,17	0,57	-3,29	1085	10,40	1,05	1,05	2,29	2,75	3,26	10,40	3,40	-14,50	4,66	4,68	A++	2,23	0,62	-3,59	1115	10,50
16+16+35+42+60	0,85	0,85	1,86	2,24	3,20	9,00	2,90	-11,50	4,15	8,50	A+++	2,17	0,57	-3,29	1085	10,40	0,98	0,98	2,15	2,58	3,71	10,40	3,40	-14,50	4,66	4,68	A++	2,23	0,62	-3,59	1115	10,50
16+16+35+42+71	0,80	0,80	1,75	2,10	3,55	9,00	2,90	-11,50	4,13	8,50	A+++	2,18	0,58	-3,29	1090	10,40	0,92	0,92	2,02	2,43	4,11	10,40	3,40	-14,50	4,68	4,68	A++	2,22	0,63	-3,63	1110	10,40
16+16+35+50+50	0,86	0,86	1,90	2,69	2,69	9,00	2,90	-11,50	3,98	8,50	A+++	2,26	0,66	-3,24	1130	10,80	1,00	1,00	2,18	3,11	3,11	10,40	3,40	-14,50	4,46	4,68	A++	2,33	0,72	-3,65	1165	10,90
16+16+35+50+60	0,81	0,81	1,78	2,54	3,06	9,00	2,90	-11,50	3,98	8,50	A+++	2,26	0,66	-3,24	1130	10,80	0,94	0,94	2,06	2,94	3,52	10,40	3,40	-14,50	4,46	4,68	A++	2,33	0,72	-3,65	1165	10,90
16+16+42+42+42	0,91	0,91	2,29	2,39	2,39	8,99	2,90	-11,50	4,18	8,50	A+++	2,15	0,49	-3,34	1075	10,30	1,06	1,06	2,76	2,76	2,76	10,40	3,40	-14,50	4,77	4,68	A++	2,18	0,53	-3,63	1090	10,20
16+16+42+42+50	0,87	0,87	2,28	2,28	2,70	9,00	2,90	-11,50	4,15	8,50	A+++	2,17	0,57	-3,29	1085	10,40	1,00	1,00	2,63	2,63	3,14	10,40	3,40	-14,50	4,66	4,68	A++	2,23	0,63	-3,63	1115	10,50
16+16+42+42+60	0,82	0,82	2,15	2,15	3,06	9,00	2,90	-11,50	4,15	8,50	A+++	2,17	0,57	-3,29	1085	10,40	0,95	0,95	2,48	2,48	3,54	10,40	3,40	-14,50	4,66	4,68	A++	2,23	0,63	-3,63	1115	10,50
16+16+42+42+71	0,83	0,83	2,16	2,59	2,59	9,00	2,90	-11,50	3,96	8,50	A+++	2,27	0,66	-3,24	1135	10,90	0,96	0,96	2,50	2,99	2,99	10,40	3,40	-14,50	4,46	4,68	A++	2,33	0,74	-3,65	1165	10,90
16+16+50+50+50	0,79	0,79	2,47	2,47	2,47	8,99	2,90	-11,50	3,91	8,50	A+++	2,30	0,76	-3,27	1150	11,00	0,91	0,91	2,86	2,86	2,86	10,40	3,40	-14,50	4,19	4,68	A++	2,48	0,86	-3,73	1240	11,70
16+20+20+20+20	1,48	1,88	1,88	1,88	1,88	9,00	2,90	-11,50	4,09	8,50	A+++	2,20	0,45	-3,49	1100	10,50	1,72	2,17	2,17	2,17	2,17	10,40	3,40	-14,50	4,86	4,68	A++	2,14	0,46	-3,68	1070	10,10
16+20+20+20+25	1,43	1,78	1,78	1,78	2,23	9,00	2,90	-11,50	4,09	8,50	A+++	2,20	0,45	-3,49	1100	10,50	1,65	2,06	2,06	2,06	2,57	10,40	3,40	-14,50	4,86	4,68	A++	2,14	0,46	-3,68	1070	10,10
16+20+20+20+35	1,30	1,62	1,62	1,62	2,84	9,00	2,90	-11,50	4,09	8,50	A+++	2,20	0,48	-3,41	1100	10,50	1,50	1,87	1,87	1,87	3,29	10,40	3,40	-14,50	4,79	4,68	A++	2,17	0,48	-3,65	1085	10,20
16+20+20+20+42	1,22	1,53	1,53	1,53	3,19	9,00	2,90	-11,50	4,07	8,50	A+++	2,21	0,48	-3,41	1105	10,60	1,41	1,76	1,76	1,76	3,71	10,40	3,40	-14,50	4,81	4,68	A++	2,16	0,48	-3,64	1080	10,20
16+20+20+20+50	1,14	1,43	1,43	1,43	3,57	9,00	2,90	-11,50	4,17	8,50	A+++	2,16	0,54	-3,28	1080	10,30	1,32	1,65	1,65	1,65	4,13	10,40	3,40	-14,50	4,73	4,68	A++	2,20	0,57	-3,58	1100	10,30
16+20+20+20+60	1,06	1,32	1,32	1,32	3,98	9,00	2,90	-11,50	4,17	8,50	A+++	2,16	0,54	-3,28	1080	10,30	1,22	1,53	1,53	1,53	4,59	10,40	3,40	-14,50	4,73	4,68	A++	2,20	0,57	-3,58	1100	10,30
16+20+20+20+71	0,98	1,22	1,22	1,22	4,36	9,00	2,90	-11,50	4,15	8,50	A+++	2,17	0,57	-3,28	1085	10,40	1,13	1,41	1,41	1,41	5,04	10,40	3,40	-14,50	4,73	4,68	A++	2,20	0,58	-3,62	1100	10,30
16+20+20+25+25	1,36	1,70	1,70	2,12	2,12	9,00	2,90	-11,50	4,09	8,50	A+++	2,20	0,45	-3,49	1100	10,50	1,58	1,96	1,96	2,45	2,45	10,40	3,40	-14,50	4,86	4,68	A++	2,14	0,46	-3,68	1070	10,10
16+20+20+25+35	1,24	1,55	1,55	1,94	2,72	9,00	2,90	-11,50	4,09	8,50	A+++	2,20	0,48	-3,41	1100	10,50	1,43	1,79	1,79	2,24	3,15	10,40	3,40	-14,50	4,79	4,68	A++	2,17	0,48	-3,65	1085	10,20
16+20+20+25+42	1,17	1,46	1,46	1,83	3,08	9,00	2,90	-11,50	4,07	8,50	A+++	2,21	0,48	-3,41	1105	10,60	1,35	1,69	1,69	2,11	3,56	10,40	3,40	-14,50	4,81	4,68	A++	2,16	0,48	-3,64	1080	10,20
16+20+20+25+50	1,10	1,37	1,37	1,72	3,44	9,00	2,90	-11,50	4,17	8,50	A+++	2,16	0,54	-3,28	1080	10,30	1,27	1,59	1,59	1,98	3,97	10,40	3,40	-14,50	4,73	4,68	A++	2,20	0,57	-3,58	1100	10,30
16+20+20+25+60	1,02	1,28	1,28	1,60	3,82	9,00	2,90	-11,50	4,17	8,50	A+++	2,16	0,54	-3,28	1080	10,30	1,18	1,48	1,48	1,84	4,42	10,40	3,40	-14,50	4,73	4,68	A++	2,20	0,57	-3,58	1100	10,30
16+20+20+25+71	0,95	1,18	1,18	1,48	4,21	9,00	2,90	-11,50	4,15	8,50	A+++	2,17	0,57	-3,28	1085	10,40	1,09	1,37	1,37	1,71	4,86	10,40	3,40	-14,50	4,73	4,68	A++	2,20	0,58	-3,62	1100	10,30
16+20+20+35+35	1,14	1,43	1,43	2,50	2,50	9,00	2,90	-11,50	4,07	8,50	A+++	2,21	0,49	-3,41	1105	10,60	1,32	1,65	1,65	2,79	2,89	10,40	3,40	-14,50	4,84	4,68	A++	2,15	0,50	-3,62	1075	10,10
16+20+20+35+42	1,08	1,35	1,35	2,37	2,85	9,00	2,90	-11,50	4,07	8,50	A+++	2,21	0,49	-3,42	1105	10,60	1,25	1,56	1,56	2,74	3,29	10,40	3,40	-14,50	4,84	4,68	A++	2,15	0,51	-3,61	1075	10,10
16+20+20+35+50	1,02	1,28	1,28	2,23	3,19	9,00	2,90	-11,50	4,15	8,50	A+++	2,17	0,57	-3,28	1085	10,40	1,18	1,48	1,48	2,58	3,68	10,40	3,40	-14,50	4,75	4,68	A++	2,19	0,60	-3,61	1095	10,30
16+20+20+35+60	0,95	1,19	1,19	2,09	3,58	9,00	2,90	-11,50	4,15	8,50	A+++	2,17	0,57	-3,28	1085	10,40	1,10	1,38	1,38	2,41	4,13	10,40	3,40	-14,50	4,75	4,68	A++	2,19	0,60	-3,61	1095	10,30
16+20+20+35+71	0,89	1,11	1,11	1,94	3,95	9,00	2,90	-11,50	4,13	8,50	A+++	2,18	0,58	-3,29	1090	10,40	1,03	1,28	1,28	2,25	4,56	10,40	3,40	-14,50	4,66	4,68	A++	2,23	0,60	-3,60	1115	10,50
16+20+20+42+42	1,02	1,29	1,29	2,70	2,70	9,00	2,90	-11,50	4,07	8,50	A+++	2,21	0,49	-3,42	1105	10,60	1,18	1,49	1,49	3,12	3,12	10,40	3,40	-14,50	4,84	4,68	A++	2,15	0,51	-3,60	1075	10,10
16+20+20+42+50	0,97	1,22	1,22	2,55	3,04	9,00	2,90	-11,50	4,15	8,50	A+++	2,17	0,57	-3,28	1085	10,40	1,12	1,41	1,41	2,95	3,51	10,40	3,40	-14,50	4,66	4,68	A++	2,23	0,60	-3,60	1115	10,50
16+20+20+42+60	0,91	1,14	1,14	2,39	3,42	9,00	2,90	-11,50	4,15	8,50	A+++	2,17	0,57	-3,28	1085	10,40	1,05	1,32	1,32	2,76	3,95	10,40	3,40	-14,50	4,66	4,68	A++	2,23	0,60	-3,60	1115	10,50
16+20+20+42+71	0,85	1,07	1,07	2,24	3,77	9,00	2,90	-11,50	4,13	8,50	A+++	2,18	0,58	-3,29	1090	10,40	0,98	1,23	1,23	2,58	4,38	10,40	3,40	-14,50	4,66	4,68	A++	2,23	0,62	-3,59	1115	10,50
16+20+20+50+50	0,94	1,15	1,15	2,88	2,88	9,00	2,90	-11,50	3,98	8,50	A+++	2,26	0,63	-3,23	1130	10,80	1,08	1,33	1,33	3,33	3,33	10,40	3,40	-14,50	4,46	4,68	A++	2,33	0,71	-3,61	1165	10,90
16+20+20+50+60	0,87	1,08	1,08	2,71	3,26	9,00	2,90	-11,50	3,98	8,50	A+++	2,26	0,63	-3,23	1130	10,80	1,00	1,25	1,25	3,13	3,77	10,40	3,40	-14,50	4,46	4,68	A++	2,33	0,71	-3,61	1165	10,90
16+20+20+50+71	0,81	1,02	1,02	2,54	3,61	9,00	2,90	-11,50	3,96	8,50	A+++	2,27	0,67	-3,24	1135	10,90	0,94	1,18	1,18	2,94	4,16	10,40	3,40	-14,50	4,46	4,68	A++	2,33	0,72	-3,66	1165	10,90
16+20+20+60+60	0,82	1,02	1,02	3,07	3,07	9,00	2,90	-11,50	3,98	8,50	A+++	2,26	0,63	-3,23	1130	10,80	0,94	1,18	1,18	3,55	3,55	10,40	3,40	-14,50	4,46	4,68	A++	2,33	0,71	-3,61	1165	10,90
16+20+25+2																																

# Free Multi R32 combinations table

## Free Multi 5x1 CU-5Z90TBE. Minimum capacity connected: 4,5 kW. Maximum capacity connected: 18,3 kW • R32 refrigerant

Indoor unit capacity	Cooling capacity (kW). Rooms					EER	SEER <sup>1)</sup>	Input power A.E.C. Current			Heating capacity (kW). Rooms					COP	SCOP <sup>1)</sup>	Input power A.E.C. Current		
	A	B	C	D	E			Total (Min - Max)	W/W	kW	kWh	230V	A	B	C			D	E	Total (Min - Max)
16+25+25+35+71	0,84	1,31	1,31	1,83	3,71	9,00	8,50	2,18	10,40	0,97	1,51	1,51	2,12	4,29	10,40	4,66	2,23	1115	10,50	
16+25+25+42+42	0,96	1,50	1,50	2,52	2,52	9,00	8,50	2,21	10,60	1,12	1,73	1,73	2,91	2,91	10,40	4,84	2,15	1075	10,10	
16+25+25+42+50	0,91	1,42	1,42	2,39	2,86	9,00	8,50	2,17	10,40	1,05	1,65	1,65	2,76	3,29	10,40	4,66	2,23	1115	10,50	
16+25+25+42+60	0,86	1,34	1,34	2,25	3,21	9,00	8,50	2,17	10,40	0,99	1,55	1,55	2,60	3,71	10,40	4,66	2,23	1115	10,50	
16+25+25+42+71	0,80	1,26	1,26	2,11	3,57	9,00	8,50	2,18	10,40	0,93	1,45	1,45	2,44	4,13	10,40	4,66	2,23	1115	10,50	
16+25+25+50+50	0,86	1,36	1,36	2,71	2,71	9,00	8,50	2,26	10,80	1,00	1,57	1,57	3,13	3,13	10,40	4,46	2,33	1165	10,90	
16+25+25+50+60	0,82	1,28	1,28	2,56	3,06	9,00	8,50	2,26	10,80	0,95	1,48	1,48	2,95	3,54	10,40	4,46	2,33	1165	10,90	
16+25+35+35+35	0,99	1,53	2,16	2,16	2,16	9,00	8,50	2,21	10,60	1,14	1,79	2,49	2,49	2,49	10,40	4,77	2,18	1090	10,20	
16+25+35+35+42	0,94	1,47	2,06	2,06	2,47	9,00	8,50	2,15	10,75	1,09	1,70	2,38	2,38	2,85	10,40	4,77	2,18	1090	10,20	
16+25+35+35+50	0,89	1,40	1,96	1,96	2,79	9,00	8,50	2,17	10,85	1,03	1,61	2,26	2,26	3,24	10,40	4,66	2,23	1115	10,50	
16+25+35+35+60	0,84	1,32	1,84	1,84	3,16	9,00	8,50	2,17	10,85	0,97	1,52	2,13	2,13	3,65	10,40	4,66	2,23	1115	10,50	
16+25+35+35+71	0,79	1,24	1,73	1,73	3,51	9,00	8,50	2,18	10,90	0,91	1,43	2,00	2,00	4,06	10,40	4,68	2,20	1110	10,40	
16+25+35+42+42	0,90	1,41	1,97	2,36	2,36	9,00	8,50	2,15	10,75	1,03	1,63	2,28	2,73	2,73	10,40	4,77	2,18	1090	10,20	
16+25+35+42+50	0,86	1,34	1,88	2,25	2,67	9,00	8,50	2,18	10,75	0,99	1,55	2,17	2,60	3,09	10,40	4,66	2,23	1115	10,50	
16+25+35+42+60	0,81	1,26	1,77	2,12	3,04	9,00	8,50	2,18	10,90	0,93	1,46	2,04	2,45	3,52	10,40	4,66	2,23	1115	10,50	
16+25+35+42+71	0,82	1,28	1,78	2,56	2,56	9,00	8,50	2,27	11,35	0,95	1,48	2,07	2,95	2,95	10,40	4,46	2,33	1165	10,90	
16+25+42+42+42	0,86	1,36	2,26	2,26	2,26	9,00	8,50	2,15	10,75	1,03	1,63	2,28	2,73	2,73	10,40	4,77	2,18	1090	10,20	
16+25+42+42+50	0,82	1,29	2,16	2,16	2,57	9,00	8,50	2,18	10,90	0,95	1,49	2,50	2,50	2,96	10,40	4,60	2,26	1130	10,60	
16+25+42+50+50	0,79	1,23	2,06	2,46	2,46	9,00	8,50	2,27	11,35	0,91	1,42	2,39	2,84	2,84	10,40	4,41	2,36	1180	11,10	
16+35+35+35+35	0,92	2,02	2,02	2,02	2,02	9,00	8,50	2,15	10,75	1,08	2,33	2,33	2,33	2,33	10,40	4,79	2,17	1085	10,20	
16+35+35+35+42	0,88	1,93	1,93	2,93	3,33	9,00	8,50	2,16	10,80	1,02	2,23	2,23	2,23	2,69	10,40	4,79	2,17	1085	10,20	
16+35+35+35+50	0,84	1,84	1,84	1,84	2,64	9,00	8,50	2,18	10,90	0,97	2,13	2,13	2,13	3,04	10,40	4,60	2,26	1130	10,60	
16+35+35+35+60	0,80	1,74	1,74	1,74	2,98	9,00	8,50	2,18	10,90	0,92	2,01	2,01	2,01	3,45	10,40	4,60	2,26	1130	10,60	
16+35+35+42+42	0,86	1,85	1,85	2,22	2,22	9,00	8,50	2,16	10,80	0,98	2,14	2,14	2,57	2,57	10,40	4,79	2,17	1085	10,20	
16+35+35+42+50	0,81	1,77	1,77	2,12	2,53	9,00	8,50	2,18	10,90	0,93	2,04	2,04	2,45	2,94	10,40	4,60	2,26	1130	10,60	
16+35+42+42+42	0,81	1,77	2,14	2,14	2,14	9,00	8,50	2,16	10,80	0,93	2,06	2,47	2,47	2,47	10,40	4,73	2,18	1090	10,20	
20+20+20+20+20	1,80	1,80	1,80	1,80	1,80	9,00	8,50	2,20	11,00	2,03	2,08	2,08	2,08	2,08	10,40	4,88	2,20	1065	10,00	
20+20+20+20+25	1,71	1,71	1,71	1,71	2,16	9,00	8,50	2,20	11,00	1,98	1,98	1,98	1,98	2,48	10,40	4,88	2,13	1065	10,00	
20+20+20+20+35	1,57	1,57	1,57	1,57	2,72	9,00	8,50	2,21	11,05	1,81	1,81	1,81	1,81	3,16	10,40	4,81	2,16	1080	10,20	
20+20+20+20+42	1,48	1,48	1,48	1,48	3,08	9,00	8,50	2,21	11,05	1,70	1,70	1,70	1,70	3,60	10,40	4,81	2,16	1080	10,20	
20+20+20+20+50	1,38	1,38	1,38	1,38	3,48	9,00	8,50	2,17	10,85	1,60	1,60	1,60	1,60	4,00	10,40	4,73	2,10	1100	10,30	
20+20+20+20+60	1,29	1,29	1,29	1,29	3,84	9,00	8,50	2,17	10,85	1,49	1,49	1,49	1,49	4,44	10,40	4,73	2,20	1100	10,30	
20+20+20+20+71	1,19	1,19	1,19	1,19	4,24	9,00	8,50	2,17	10,85	1,38	1,38	1,38	1,38	4,88	10,40	4,75	2,19	1095	10,30	
20+20+20+25+25	1,64	1,64	1,64	2,04	2,04	9,00	8,50	2,20	11,00	1,89	1,89	1,89	2,36	2,36	10,40	4,88	2,13	1065	10,00	
20+20+20+25+35	1,50	1,50	1,50	1,88	2,62	9,00	8,50	2,21	11,05	1,73	1,73	1,73	2,17	3,04	10,40	4,81	2,16	1080	10,20	
20+20+20+25+42	1,42	1,42	1,42	1,77	2,97	9,00	8,50	2,21	11,05	1,64	1,64	1,64	2,05	3,43	10,40	4,81	2,16	1080	10,20	
20+20+20+25+50	1,33	1,33	1,33	1,67	3,34	9,00	8,50	2,17	10,85	1,54	1,54	1,54	1,93	3,85	10,40	4,73	2,20	1100	10,30	
20+20+20+25+60	1,24	1,24	1,24	1,55	3,73	9,00	8,50	2,17	10,85	1,43	1,43	1,43	1,79	4,32	10,40	4,73	2,20	1100	10,30	
20+20+20+25+71	1,15	1,15	1,15	1,44	4,11	9,00	8,50	2,17	10,85	1,33	1,33	1,33	1,67	4,74	10,40	4,75	2,19	1095	10,30	
20+20+20+35+35	1,38	1,38	1,38	2,43	2,43	9,00	8,50	2,21	11,05	1,60	1,60	1,60	2,80	2,80	10,40	4,84	2,15	1075	10,10	
20+20+20+35+42	1,31	1,31	1,31	2,30	2,77	9,00	8,50	2,21	11,05	1,52	1,52	1,52	2,66	3,18	10,40	4,84	2,15	1075	10,10	
20+20+20+35+50	1,24	1,24	1,24	2,17	3,11	9,00	8,50	2,17	10,85	1,43	1,43	1,43	2,51	3,60	10,40	4,66	2,23	1115	10,50	
20+20+20+35+60	1,16	1,16	1,16	2,03	3,49	9,00	8,50	2,17	10,85	1,34	1,34	1,34	2,35	4,03	10,40	4,66	2,23	1115	10,50	
20+20+20+35+71	1,08	1,08	1,08	1,90	3,86	9,00	8,50	2,18	10,90	1,25	1,25	1,25	2,19	4,46	10,40	4,66	2,23	1115	10,50	
20+20+20+42+42	1,25	1,25	1,25	2,62	2,62	8,99	8,50	2,15	10,75	1,34	1,44	1,44	3,04	3,04	10,40	4,77	2,18	1090	10,20	
20+20+20+42+50	1,18	1,18	1,18	2,49	2,97	9,00	8,50	2,17	10,85	1,27	1,37	1,37	2,87	3,42	10,40	4,66	2,23	1115	10,50	
20+20+20+42+60	1,11	1,11	1,11	2,33	3,34	9,00	8,50	2,17	10,85	1,28	1,28	1,28	2,70	3,86	10,40	4,66	2,23	1115	10,50	
20+20+20+42+71	1,04	1,04	1,04	2,18	3,70	9,00	8,50	2,18	10,90	1,20	1,20	1,20	2,52	4,28	10,40	4,66	2,23	1115	10,50	
20+20+20+50+50	1,13	1,13	1,13	2,80	2,80	8,99	8,50	2,26	11,30	1,30	1,30	1,30	3,25	3,25	10,40	4,46	2,33	1165	10,90	
20+20+20+50+60	1,06	1,06	1,06	2,65	3,17	9,00	8,50	2,26	11,30	1,22	1,22	1,22	3,06	3,68	10,40	4,46	2,33	1165	10,90	
20+20+20+50+71	0,99	0,99	0,99	2,49	3,54	9,00	8,50	2,27	11,35	1,15	1,15	1,15	2,87	4,08	10,40	4,46	2,33	1165	10,90	
20+20+20+60+60	1,00	1,00	1,00	3,00	3,00	9,00	8,50	2,26	11,30	1,16	1,16	1,16	3,46	3,46	10,40	4,46	2,33	1165	10,90	
20+20+25+25+25	1,56	1,56	1,56	1,96	1,96	9,00	8,50	2,20	11,00	1,81	1,81	2,26	2,26	2,26	10,40	4,88	2,13	1065	10,00	
20+20+25+25+35	1,44	1,44	1,44	1,80	2,52	9,00	8,50	2,21	11,05	1,66	1,66	2,08	2,08	2,92	10,40	4,81	2,16	1080	10,20	
20+20+25+25+42	1,36	1,36	1,36	1,70	2,88	9,00	8,50	2,21	11,05	1,58	1,58	1,97	1,97	3,30	10,40	4,81	2,16	1080	10,20	
20+20+25+25+50	1,29	1,29	1,29	1,61	3,20	9,00	8,50	2,17	10,85	1,49	1,49	1,86	1,86	3,70	10,40	4,73	2,20	1100	10,30	
20+20+25+25+60	1,20	1,20	1,20	1,50	3,60	9,00	8,50	2,17	10,85	1,39	1,39	1,73	1,73	4,16	10,40	4,73	2,20	1100	10,30	
20+20+25+25+71	1,12	1,12	1,12	1,40	3,96	9,00	8,50	2,17	10,85	1,29	1,29	1,61	1,61	4,60	10,40	4,75	2,19	1095	10,30	
20+20+25+35+35	1,33	1,33	1,33	2,33	2,33	9,00	8,50	2,21	11,05	1,60	1,54	1,92	2,70	2,70	10,40	4,84	2,15	1075	10,10	
20+20+25+35+42	1,27	1,27	1,27	2,22	2,66	9,00	8,50	2,21	11,05	1,46	1,46	1,83	2,56	3,09	10,40	4,8				



## Free Multi 5x1 CU-5Z90TBE. Minimum capacity connected: 4,5 kW. Maximum capacity connected: 18,3 kW • R32 refrigerant

Indoor unit capacity	Cooling capacity (kW). Rooms					EER	SEER <sup>1)</sup>	Input power rating			A.E.C. Current	Heating capacity (kW). Rooms					COP	SCOP <sup>1)</sup>	Input power rating			A.E.C. Current					
	A	B	C	D	E			Total (Min-Max)	W/W	kW		kWh	230V	A	B	C			D	E	Total (Min-Max)		W/W	kW	kWh	230V	
	20+25+25+25+25	1,48	1,88	1,88	1,88			1,88	9,00	2,90		-11,50	4,09	<b>8,50 A+++</b>	2,20	[0,48 - 3,49]			1100	10,50	1,72		2,17	2,17	2,17	2,17	10,40
20+25+25+25+35	1,38	1,73	1,73	1,73	2,43	9,00	2,90	-11,50	4,07	<b>8,50 A+++</b>	2,21	[0,48 - 3,41]	1105	10,60	1,60	2,00	2,00	2,00	2,80	10,40	[3,40 - 14,50]	4,81	<b>4,68 A++</b>	2,16	[0,48 - 3,64]	1080	10,20
20+25+25+25+42	1,31	1,64	1,64	1,64	2,77	9,00	2,90	-11,50	4,07	<b>8,50 A+++</b>	2,21	[0,49 - 3,41]	1105	10,60	1,52	1,90	1,90	1,90	3,18	10,40	[3,40 - 14,50]	4,81	<b>4,68 A++</b>	2,16	[0,49 - 3,63]	1080	10,20
20+25+25+25+50	1,24	1,55	1,55	1,55	3,11	9,00	2,90	-11,50	4,15	<b>8,50 A+++</b>	2,17	[0,54 - 3,28]	1085	10,40	1,43	1,79	1,79	1,79	3,60	10,40	[3,40 - 14,50]	4,73	<b>4,68 A++</b>	2,20	[0,58 - 3,63]	1100	10,30
20+25+25+25+60	1,16	1,45	1,45	1,45	3,49	9,00	2,90	-11,50	4,15	<b>8,50 A+++</b>	2,17	[0,54 - 3,28]	1085	10,40	1,34	1,68	1,68	1,68	4,02	10,40	[3,40 - 14,50]	4,73	<b>4,68 A++</b>	2,20	[0,58 - 3,63]	1100	10,30
20+25+25+25+71	1,08	1,36	1,36	1,36	3,84	9,00	2,90	-11,50	4,15	<b>8,50 A+++</b>	2,17	[0,57 - 3,28]	1085	10,40	1,25	1,57	1,57	1,57	4,44	10,40	[3,40 - 14,50]	4,75	<b>4,68 A++</b>	2,19	[0,59 - 3,61]	1095	10,30
20+25+25+35+35	1,28	1,61	1,61	2,25	2,25	9,00	2,90	-11,50	4,07	<b>8,50 A+++</b>	2,21	[0,49 - 3,42]	1105	10,60	1,48	1,86	1,86	2,60	2,60	10,40	[3,40 - 14,50]	4,84	<b>4,68 A++</b>	2,15	[0,51 - 3,61]	1075	10,10
20+25+25+35+42	1,22	1,53	1,53	2,14	2,58	9,00	2,90	-11,50	4,07	<b>8,50 A+++</b>	2,21	[0,49 - 3,42]	1105	10,60	1,41	1,77	1,77	2,48	2,97	10,40	[3,40 - 14,50]	4,84	<b>4,68 A++</b>	2,15	[0,51 - 3,60]	1075	10,10
20+25+25+35+50	1,16	1,45	1,45	2,03	2,91	9,00	2,90	-11,50	4,15	<b>8,50 A+++</b>	2,17	[0,57 - 3,28]	1085	10,40	1,34	1,68	1,68	2,35	3,35	10,40	[3,40 - 14,50]	4,66	<b>4,68 A++</b>	2,23	[0,60 - 3,60]	1115	10,50
20+25+25+35+60	1,09	1,36	1,36	1,91	3,28	9,00	2,90	-11,50	4,15	<b>8,50 A+++</b>	2,17	[0,57 - 3,28]	1085	10,40	1,26	1,58	1,58	2,21	3,77	10,40	[3,40 - 14,50]	4,66	<b>4,68 A++</b>	2,23	[0,60 - 3,60]	1115	10,50
20+25+25+35+71	1,02	1,28	1,28	1,79	3,63	9,00	2,90	-11,50	4,13	<b>8,50 A+++</b>	2,18	[0,58 - 3,29]	1090	10,40	1,18	1,48	1,48	2,07	4,19	10,40	[3,40 - 14,50]	4,66	<b>4,68 A++</b>	2,23	[0,62 - 3,59]	1115	10,50
20+25+25+42+42	1,18	1,46	1,46	2,45	2,45	9,00	2,90	-11,50	4,07	<b>8,50 A+++</b>	2,21	[0,49 - 3,42]	1105	10,60	1,34	1,69	1,69	2,84	2,84	10,40	[3,40 - 14,50]	4,77	<b>4,68 A++</b>	2,18	[0,52 - 3,59]	1090	10,20
20+25+25+42+50	1,11	1,39	1,39	2,33	2,78	9,00	2,90	-11,50	4,15	<b>8,50 A+++</b>	2,17	[0,57 - 3,28]	1085	10,40	1,28	1,60	1,60	2,70	3,22	10,40	[3,40 - 14,50]	4,66	<b>4,68 A++</b>	2,23	[0,61 - 3,59]	1115	10,50
20+25+25+42+60	1,05	1,31	1,31	2,20	3,13	9,00	2,90	-11,50	4,15	<b>8,50 A+++</b>	2,17	[0,57 - 3,28]	1085	10,40	1,21	1,51	1,51	2,54	3,63	10,40	[3,40 - 14,50]	4,66	<b>4,68 A++</b>	2,23	[0,61 - 3,59]	1115	10,50
20+25+25+42+71	0,98	1,23	1,23	2,07	3,49	9,00	2,90	-11,50	4,13	<b>8,50 A+++</b>	2,18	[0,58 - 3,29]	1090	10,40	1,14	1,42	1,42	2,39	4,03	10,40	[3,40 - 14,50]	4,66	<b>4,68 A++</b>	2,23	[0,63 - 3,63]	1115	10,50
20+25+25+50+50	1,06	1,32	1,32	2,65	2,65	9,00	2,90	-11,50	3,98	<b>8,50 A+++</b>	2,26	[0,66 - 3,23]	1130	10,80	1,22	1,53	1,53	3,06	3,06	10,40	[3,40 - 14,50]	4,46	<b>4,68 A++</b>	2,33	[0,72 - 3,66]	1165	10,90
20+25+25+50+60	1,00	1,25	1,25	2,50	3,00	9,00	2,90	-11,50	3,98	<b>8,50 A+++</b>	2,26	[0,66 - 3,23]	1130	10,80	1,16	1,44	1,44	2,89	3,47	10,40	[3,40 - 14,50]	4,46	<b>4,68 A++</b>	2,33	[0,72 - 3,66]	1165	10,90
20+25+25+50+71	1,20	1,50	2,10	2,10	2,10	9,00	2,90	-11,50	4,19	<b>8,50 A+++</b>	2,15	[0,49 - 3,34]	1075	10,30	1,38	1,73	2,43	2,43	2,43	10,40	[3,40 - 14,50]	4,77	<b>4,68 A++</b>	2,18	[0,52 - 3,64]	1090	10,20
20+25+35+35+42	1,15	1,43	2,01	2,01	2,40	9,00	2,90	-11,50	4,19	<b>8,50 A+++</b>	2,15	[0,50 - 3,34]	1075	10,30	1,32	1,66	2,32	2,32	2,78	10,40	[3,40 - 14,50]	4,77	<b>4,68 A++</b>	2,18	[0,53 - 3,63]	1090	10,20
20+25+35+35+50	1,09	1,36	1,91	1,91	2,73	9,00	2,90	-11,50	4,13	<b>8,50 A+++</b>	2,18	[0,58 - 3,29]	1090	10,40	1,26	1,58	2,21	2,21	3,14	10,40	[3,40 - 14,50]	4,66	<b>4,68 A++</b>	2,23	[0,63 - 3,63]	1115	10,50
20+25+35+35+60	1,03	1,29	1,80	1,80	3,08	9,00	2,90	-11,50	4,13	<b>8,50 A+++</b>	2,18	[0,58 - 3,29]	1090	10,40	1,19	1,49	2,08	2,08	3,56	10,40	[3,40 - 14,50]	4,66	<b>4,68 A++</b>	2,23	[0,63 - 3,63]	1115	10,50
20+25+35+42+42	1,10	1,37	1,93	2,30	2,30	9,00	2,90	-11,50	4,19	<b>8,50 A+++</b>	2,15	[0,52 - 3,35]	1075	10,30	1,27	1,59	2,22	2,66	2,66	10,40	[3,40 - 14,50]	4,79	<b>4,68 A++</b>	2,17	[0,54 - 3,62]	1085	10,20
20+25+35+42+50	1,05	1,31	1,83	2,20	2,61	9,00	2,90	-11,50	4,13	<b>8,50 A+++</b>	2,18	[0,58 - 3,29]	1090	10,40	1,21	1,51	2,12	2,54	3,02	10,40	[3,40 - 14,50]	4,60	<b>4,68 A++</b>	2,26	[0,63 - 3,62]	1130	10,60
20+25+35+42+60	0,99	1,24	1,73	2,08	2,96	9,00	2,90	-11,50	4,13	<b>8,50 A+++</b>	2,18	[0,58 - 3,29]	1090	10,40	1,14	1,43	2,00	2,40	3,43	10,40	[3,40 - 14,50]	4,60	<b>4,68 A++</b>	2,26	[0,63 - 3,62]	1130	10,60
20+25+35+50+50	1,00	1,25	1,75	2,50	2,50	9,00	2,90	-11,50	3,96	<b>8,50 A+++</b>	2,27	[0,67 - 3,24]	1135	10,90	1,16	1,44	2,02	2,89	2,89	10,40	[3,40 - 14,50]	4,41	<b>4,68 A++</b>	2,36	[0,75 - 3,64]	1180	11,10
20+25+42+42+42	1,05	1,32	2,21	2,21	2,21	9,00	2,90	-11,50	4,19	<b>8,50 A+++</b>	2,15	[0,52 - 3,35]	1075	10,30	1,23	1,52	2,55	2,55	2,55	10,40	[3,40 - 14,50]	4,79	<b>4,68 A++</b>	2,17	[0,54 - 3,61]	1085	10,20
20+25+42+42+50	1,01	1,26	2,11	2,11	2,51	9,00	2,90	-11,50	4,13	<b>8,50 A+++</b>	2,18	[0,58 - 3,29]	1090	10,40	1,16	1,45	2,44	2,44	2,91	10,40	[3,40 - 14,50]	4,60	<b>4,68 A++</b>	2,26	[0,65 - 3,61]	1130	10,60
20+35+35+35+35	1,12	1,97	1,97	1,97	1,97	9,00	2,90	-11,50	4,17	<b>8,50 A+++</b>	2,16	[0,53 - 3,35]	1080	10,30	1,28	2,28	2,28	2,28	2,28	10,40	[3,40 - 14,50]	4,79	<b>4,68 A++</b>	2,17	[0,54 - 3,61]	1085	10,20
20+35+35+35+42	1,08	1,89	1,89	1,89	2,25	9,00	2,90	-11,50	4,17	<b>8,50 A+++</b>	2,16	[0,53 - 3,35]	1080	10,30	1,25	2,18	2,18	2,18	2,61	10,40	[3,40 - 14,50]	4,79	<b>4,68 A++</b>	2,17	[0,55 - 3,60]	1085	10,20
20+35+35+35+50	1,03	1,80	1,80	1,80	2,57	9,00	2,90	-11,50	4,13	<b>8,50 A+++</b>	2,18	[0,58 - 3,29]	1090	10,40	1,19	2,08	2,08	2,97	2,97	10,40	[3,40 - 14,50]	4,60	<b>4,68 A++</b>	2,26	[0,65 - 3,61]	1130	10,60
20+35+35+42+42	1,04	1,81	1,81	2,17	2,17	9,00	2,90	-11,50	4,17	<b>8,50 A+++</b>	2,16	[0,53 - 3,35]	1080	10,30	1,20	2,09	2,09	2,51	2,51	10,40	[3,40 - 14,50]	4,73	<b>4,68 A++</b>	2,20	[0,56 - 3,59]	1100	10,30
20+35+35+42+50	0,99	1,73	1,73	2,08	2,47	9,00	2,90	-11,50	4,13	<b>8,50 A+++</b>	2,18	[0,58 - 3,29]	1090	10,40	1,14	2,00	2,00	2,40	2,86	10,40	[3,40 - 14,50]	4,60	<b>4,68 A++</b>	2,26	[0,66 - 3,60]	1130	10,60
20+35+42+42+42	0,99	1,74	2,09	2,09	2,09	9,00	2,90	-11,50	4,17	<b>8,50 A+++</b>	2,16	[0,53 - 3,35]	1080	10,30	1,15	2,02	2,41	2,41	2,41	10,40	[3,40 - 14,50]	4,73	<b>4,68 A++</b>	2,20	[0,57 - 3,58]	1100	10,30
25+25+25+25+25	1,80	1,80	1,80	1,80	1,80	9,00	2,90	-11,50	4,09	<b>8,50 A+++</b>	2,20	[0,48 - 3,49]	1100	10,50	2,08	2,08	2,08	2,08	2,08	10,40	[3,40 - 14,50]	4,88	<b>4,68 A++</b>	2,13	[0,46 - 3,67]	1065	10,00
25+25+25+25+35	1,67	1,67	1,67	1,67	2,32	9,00	2,90	-11,50	4,07	<b>8,50 A+++</b>	2,21	[0,48 - 3,41]	1105	10,60	1,93	1,93	1,93	1,93	2,68	10,40	[3,40 - 14,50]	4,81	<b>4,68 A++</b>	2,16	[0,48 - 3,64]	1080	10,20
25+25+25+25+42	1,58	1,58	1,58	1,58	2,68	9,00	2,90	-11,50	4,07	<b>8,50 A+++</b>	2,21	[0,49 - 3,41]	1105	10,60	1,83	1,83	1,83	1,83	3,08	10,40	[3,40 - 14,50]	4,81	<b>4,68 A++</b>	2,16	[0,49 - 3,63]	1080	10,20
25+25+25+25+50	1,50	1,50	1,50	1,50	3,00	9,00	2,90	-11,50	4,15	<b>8,50 A+++</b>	2,17	[0,54 - 3,28]	1085	10,40	1,73	1,73	1,73	1,73	3,48	10,40	[3,40 - 14,50]	4,73	<b>4,68 A++</b>	2,20	[0,58 - 3,63]	1100	10,30
25+25+25+25+60	1,41	1,41	1,41	1,41	3,36	9,00	2,90	-11,50	4,15	<b>8,50 A+++</b>	2,17	[0,54 - 3,28]	1085	10,40	1,63	1,63	1,63	1,63	3,88	10,40	[3,40 - 14,50]	4,73	<b>4,68 A++</b>	2,20	[0,58 - 3,63]	1100	10,30
25+25+25+25+71	1,32	1,32	1,32	1,32	3,72	9,00	2,90	-11,50	4,15	<b>8,50 A+++</b>	2,17	[0,57 - 3,28]	1085	10,40	1,52	1,52	1,52	1,52	4,32	10,40	[3,40 - 14,50]	4,75	<b>4,68 A++</b>	2,19	[0,59 - 3,61]	1095	10,30

# PACi outdoor units. Energy saving concept



**Product quality and safety.** All Panasonic air conditioners undergo strict quality and safety tests before sale. This rigorous process includes obtaining all necessary safety approvals, to ensure that all air conditioners we sell are not only built to the highest market standards, but are also completely safe.

### PACi R32 refrigerant gas

**Panasonic recommends R32 because of its lower Global Warming Potential (GWP). Compared to R22 and R410A, R32 has a very low potential impact on global warming.**

Panasonic is concerned with protecting and maintaining the environment. In line with the with European countries participating in the Montreal Protocol, protecting the ozone layer and preventing global warming, Panasonic is leading the switch to R32.

## 1 Installation innovation

- Extremely easy to install, practically the same as R410A.  
(Just remember to verify that the pressure gauge and vacuum pump are compatible with R32)
- This refrigerant is 100 % pure, which makes it easier to recycle and reuse

## 2 Environmental innovation

- Zero impact on the ozone layer
- 75 % less impact on global warming

## 3 Economic and energy consumption innovation

- Lower cost and greater savings
- Higher energy efficiency than R410A

### PACi Elite: Next generation of commercial air conditioning

Outstanding performance at low temperatures, high energy efficiency, power consumption in remote control display. The structure and energy saving design of fans, fan motors, compressors and heat exchangers result in high COP value, which ranks as one of the highest class in the industry. Additional benefits include reduced CO<sub>2</sub> emissions, energy consumption and operating costs.

#### PACi Elite. From 3,6 to 25,0 kW.

- Meeting all necessary safety approvals to ensure quality and safety

- Top class SEER: A+++ / SCOP: A+++ at 3,6 kW (in 90x90 Cassette)
- Cooling operation is possible when outdoor temperature as high as 46 °C
- DC inverter technology combined with R32 and R410A
- Cooling operation is possible when outdoor temperature is as low as -20 °C (for 10,0 kW ~ 14,0 kW with 30 m maximum pipe length)
- Heating operation is possible when outdoor temperature is as low as -20 °C
- Compact outdoor units
- Auto restart from outdoor unit
- Twin, Triple and Double-Twin connection possible

### PACi Standard: For economy and value

With high quality design and engineering, the PACi Standard is the perfect solution for projects which demand quality on a limited budget. In addition, its compact and lightweight design makes it ideal for installations with limited space including small commercial and residential applications.

The outdoor unit is much more compact than the previous model. The slim and lightweight design means the PACi outdoor unit can be installed in a wide variety of locations.

#### PACi Standard. From 6,0 to 14,0 kW.

- Good balance of system cost vs energy efficiency
- Top class SEER/SCOP in the standard inverter category SEER: A++ / SCOP: A++ at 6,0 and 7,1 kW (in 90x90 Cassette)
- Interchangeable controller with ECOi
- Compact outdoor units
- Twin connection possible
- Cooling operation down to -10 °C and heating operation down to -15 °C

### Big PACi Elite R32

20,0 – 25,0 kW is ideally suited for small and mid retail applications.

In addition to its lightweight, split-able, compact body, the newly designed Hide Away unit enables easy installation and pipe work within a narrow void.

#### Panasonic Big PACi, not only environmental friendly but also a groundbreaking product.

- High efficiency with Panasonic compressor as the driving force
- Compact and light indoor body
- Easy pipe work with split-able Hide Away indoor design
- Separable indoor unit allows for flexible installation to fit in narrow void
- Water Heat Exchanger compatibility
- Bluefin anti-rust coating as standard
- Cloud Control compatible

# New wired remote controller - CZ-RTC6 / CZ-RTC6BL / CZ-RTC6BLW

This series give you comfort and control, meeting the varying needs of multi users. Accessible, flexible and convenient. Perfectly meeting modern control needs.



## 1 Intuitive control with stylish design profile

- Simple operation at a glance
- Clean face with full flat & black LCD display
- Compact body only 86x86

## 2 Control comfort with your smartphone for multi users

- Flexible control options with IoT integration
- New Panasonic H&C Control App for daily remote control operation
- Panasonic Comfort Cloud App for remote operation 24/7/365

## 3 Easy maintenance with service support App

- Quick and easy App set-up for system setting
- Panasonic H&C Diagnosis App enables the user to obtain detailed system operation data

### Simple & modern design

Sophisticated design with black flat panel and compact body. From residential to commercial, the wired remote controller series perfectly matches with all kinds of modern building.

### Intuitive operation

It enables to recognize each functions with a simple glance. Classical standard elements are suitable for long-term use.

### Flexible control option with IoT integration

New wired remote controller series are fully integrated with IoT solutions developed by Panasonic. Detailed operation, maintenance setting and service operation are all possible with smartphone or tablet.

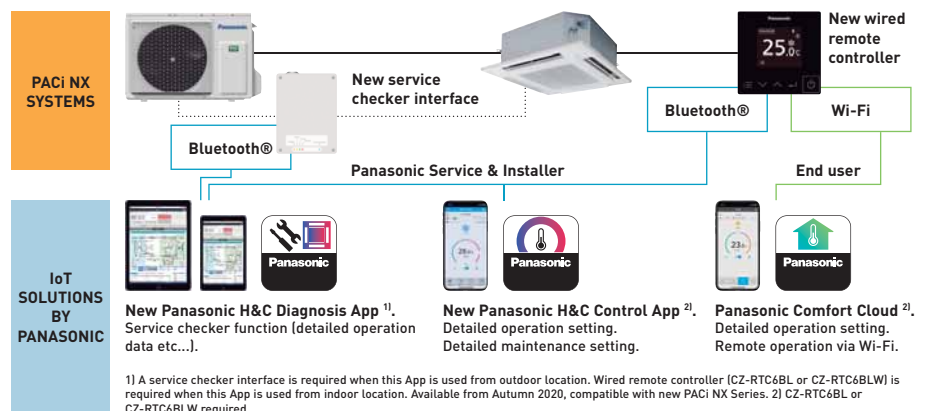

### Wired remote controller line-up

		Wi-Fi	Bluetooth®
CZ-RTC6	Non-wireless	—	—
CZ-RTC6BL	Bluetooth®	—	✓
CZ-RTC6BLW*	Wi-Fi & Bluetooth®	✓	✓

\* Available from Autumn 2020, compatible with new PACi NX Series.

### New service checker interface



The new service checker interface provides easy access to service parameters and service checker data via Bluetooth®.

- A new service checker interface\* for PACi NX Series
- Bluetooth® connection
- Panasonic H&C Diagnosis App

\* Available as a spare part, compatible with new PACi NX Series.

# Commercial Wi-Fi Adaptor

Panasonic CZ-CAPWFC1 interface adaptor, allows connection of one or a group of indoor units to Panasonic Comfort Cloud App, which provides control, monitoring, scheduling and error alerts.



## Advanced smartphone control

Control PACi and ECOi units with your smartphone from wherever and whenever you are, by using Panasonic Comfort Cloud App and Commercial Wi-Fi Adaptor. This scalable solution is ideal for one system, one site or multiple locations. Coupling the adaptor with the already feature rich systems, makes it an ideal solution for residential and commercial applications.

### 1 From 1 to 200 units

User can control up to 10 different sites, with up to 20 units / groups per site.

### 2 1 indoor or 1 group

One simple Wi-Fi Adaptor CZ-CAPWFC1 can be connected to 1 indoor unit or to a group (maximum 8 units).

### 3 Multi user

The Panasonic Comfort Cloud App allows multi-user access control. Restrict user access to specific units.

### 4 Easy scheduling

Complex weekly scheduling made simple. Not only for one unit, but across multiple sites and from a smartphone.

### 5 Energy monitor

See the estimated power consumption and compare with other periods, to see how energy consumption can be reduced even more. Check list of units that provides consumption\*.

\* Function available depending on the model.

### 6 Error codes

Error code notification through the App, provides early notification and allows for faster repair.

## Connection Diagram

Commercial Wi-Fi Adaptor wiring length is 1,9 m and connects to indoor unit thru T10 connector and R1/R2 terminal connectors.

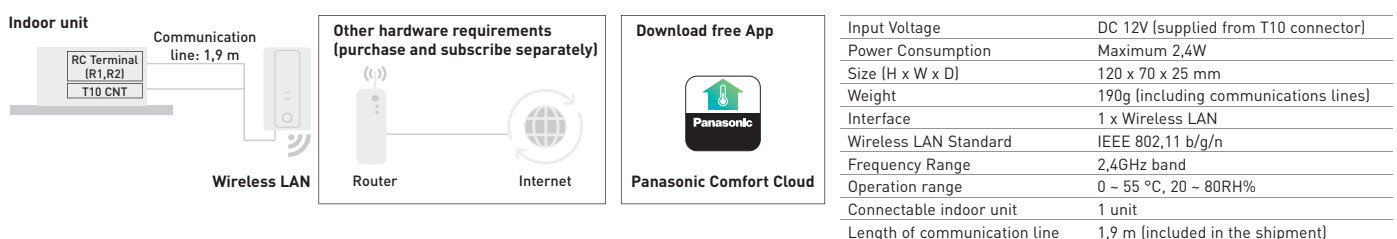













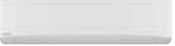
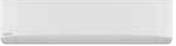
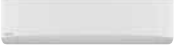

























## Cloud control is available for all indoor units with P-link

Compatible indoor units type: Model code starting with "S-" (excludes S-80/125MW1E5).

Incompatible indoor units type: Model code starting with "PAW-", "FY-" and S-80/125MW1E5.

## Range of Commercial units R32

Page	Indoor units	2,5 kW	3,5 ~ 3,6 kW	4,5 kW	5,0 kW	6,0 kW
P. 128	Wall-mounted Professional Inverter -20 °C • R32 refrigerant	 KIT-Z25-TKEA	 KIT-Z35-TKEA	 KIT-Z42-TKEA	 KIT-Z50-TKEA	
P. 132	Wall-mounted Inverter+ • R32 refrigerant		 S-36PK2E5B	 S-45PK2E5B 1)	 S-50PK2E5B	 S-60PK2E5B
P. 130	4 Way 60x60 Cassette Inverter • R32 refrigerant	 CS-Z25UB4EAW	 CS-Z35UB4EAW		 CS-Z50UB4EAW	 CS-Z60UB4EAW
P. 136	4 Way 60x60 Cassette Inverter+ • R32 refrigerant		 S-36PY2E5B	 S-45PY2E5B 1)	 S-50PY2E5B	
P. 138	4 Way 90x90 Cassette Inverter+ • R32 refrigerant		 S-36PU2E5B	 S-45PU2E5B 1)	 S-50PU2E5B	 S-60PU2E5B
P. 142	Ceiling Inverter+ • R32 refrigerant		 S-36PT2E5B	 S-45PT2E5B 1)	 S-50PT2E5B	 S-60PT2E5B
P. 131	Low Static Pressure Hide Away Inverter • R32 refrigerant	 CS-Z25UD3EAW	 CS-Z35UD3EAW		 CS-Z50UD3EAW	 CS-Z60UD3EAW
P. 146	High Static Pressure Hide Away Inverter+ • R32 refrigerant		 S-36PF1E5B	 S-45PF1E5B 1)	 S-50PF1E5B	 S-60PF1E5B
P. 150	Low Static Pressure Hide Away Inverter+ • R32 refrigerant		 S-36PN1E5B	 S-45PN1E5B 1)	 S-50PN1E5B	 S-60PN1E5B
P. 154	High Static Pressure Hide Away 20-25 kW Inverter+ • R32 refrigerant					
P. 168	Air Handling Unit Kit 3,6-25,0 kW				 PAW-280PAH2(M/L)	 PAW-280PAH2(M/L)
<b>Outdoor units</b>			<b>3,6 kW</b>		<b>5,0 kW</b>	<b>6,0 kW</b>
PACi Elite • R32 refrigerant			 U-36PZH2E5		 U-50PZH2E5	 U-60PZH2E5
PACi Standard • R32 refrigerant						 U-60PZ2E5

1) The 4,5 kW indoor unit are only available only for Twin, Triple and Double-Twin combinations. \* U-\_\_E5 Single Phase / U-\_\_E8 Three Phase.

7,1 kW

10,0 kW

12,5 kW

14,0 kW

20,0 kW

25,0 kW



KIT-Z71-TKEA



S-71PK2E5B



S-100PK2E5B (9,0 kW)



S-71PU2E5B



S-100PU2E5B



S-125PU2E5B



S-140PU2E5B



S-71PT2E5B



S-100PT2E5B



S-125PT2E5B



S-140PT2E5B



S-71PF1E5B



S-100PF1E5B



S-125PF1E5B



S-140PF1E5B



S-71PN1E5B



S-100PN1E5B



S-125PN1E5B



S-140PN1E5B



S-200PE3E5B



S-250PE3E5B



PAW-280PAH2(M/L)



PAW-280PAH2(M/L)



PAW-280PAH2(M/L)



PAW-280PAH2(M/L)



PAW-280PAH2(M/L)



PAW-280PAH2(M/L)

7,1 kW

10,0 kW

12,5 kW

14,0 kW

20,0 kW

25,0 kW



U-71PZH2E5 / U-71PZH2E8



U-100PZH2E5 / U-100PZH2E8



U-125PZH2E5 / U-125PZH2E8



U-140PZH2E5 / U-140PZH2E8



U-200PZH2E8



U-250PZH2E8



U-71PZ2E5



U-100PZ2E5 / U-100PZ2E8



U-125PZ2E5 / U-125PZ2E8



U-140PZ2E5 / U-140PZ2E8

# Solutions for server rooms

High efficiency products for 24/7 applications. Panasonic has developed a complete range of solutions for server rooms which efficiently protect your servers, keeping them at an appropriate temperature even when the outdoor temperature is below -20 °C.



## 1 Designed for 24h/7d a week operation

High efficiency all year round. This Wall-mounted air conditioner is designed for professional, critical applications such as computer rooms where reliable cooling inside the room is necessary even when the outside temperature is low.

## 2 High seasonal performance

Highest Energy Rating: A+++ (2,5 to 5,0 kW units). Highly efficient performance - even at -20 °C outside. Uses new R32 refrigerant.

## 3 Server room logic control

PAW-SERVER-PKEA: Group wiring of 2 TKEA systems ensures auto individual control. BMS interface: Panasonic offer different interfaces for integrate to Modbus and BACnet.

## 4 More comfort

Indoor Fan. Cross-Flow-Fan: High durability rolling bearings, large size (φ105 mm) fan. High efficiency blade. Random pitch blade (low sound) Compressor: DC2P Panasonic original compressor, with high efficiency and reliability.

### High efficiency all the year

#### Key points:

- From 2,5 to 7,1 kW with TKEA R32 refrigerant units A+++ in cooling
- Backup function
- Redundancy function
- Alternative run function
- Error information by Dry Contact
- Operation even at -20 °C outdoor temperature
- High seasonal performance
- Product design for 24/7 operation

### Exceptional efficiency means exceptional savings

#### TKEA provides high capacity at -20 °C!

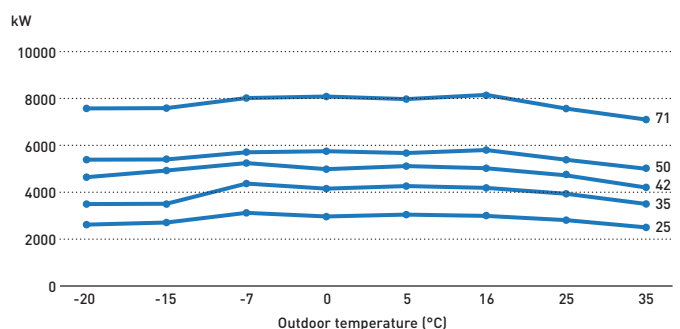

### PAW-SERVER-PKEA Logic

#### Rotation operation time line.

Every 12 hours units change operation ON/OFF to increase compressor lifecycle.

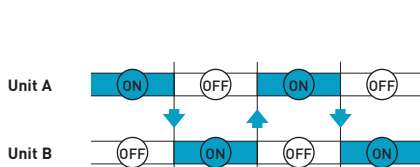

#### Backup operation time line.

When unit A has an error, unit B switches on automatically and gives the error output signal.

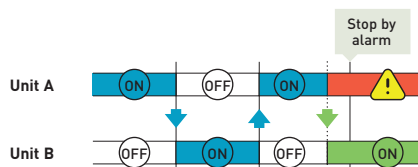

#### Support operation time line.

When room temperature rises to than 28 °C, both units work together and automatically give an output error signal.

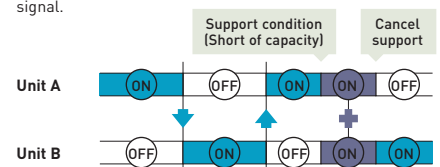





## Wall-mounted Professional Inverter -20 °C • R32 refrigerant

KIT			KIT-Z25-TKEA	KIT-Z35-TKEA	KIT-Z42-TKEA	KIT-Z50-TKEA	KIT-Z71-TKEA
Cooling capacity	Nominal (Min - Max)	kW	2,50 [0,85 - 3,00]	3,50 [0,85 - 4,00]	4,20 [0,98 - 5,00]	5,00 [0,98 - 6,00]	7,10 [0,98 - 8,10]
EER <sup>1)</sup>	Nominal (Min - Max)	W/W	4,90 [5,00 - 4,29]	4,07 [5,00 - 3,64]	3,82 [4,90 - 3,25]	3,60 [3,50 - 3,09]	3,17 [2,33 - 3,03]
<b>SEER<sup>2)</sup></b>			<b>8,50 A+++</b>	<b>8,50 A+++</b>	<b>8,50 A+++</b>	<b>8,50 A+++</b>	<b>6,10 A++</b>
Pdesign		kW	2,50	3,50	4,20	5,00	7,10
Input power cooling	Nominal (Min - Max)	kW	0,51 [0,17 - 0,70]	0,86 [0,17 - 1,10]	1,10 [0,20 - 1,54]	1,39 [0,28 - 1,94]	2,24 [0,42 - 2,67]
Annual energy consumption <sup>3)</sup>		kWh/a	103	144	173	206	407
Heating capacity	Nominal (Min - Max)	kW	3,40 [0,85 - 5,40]	4,00 [0,85 - 6,60]	5,40 [0,98 - 7,25]	5,80 [0,98 - 8,00]	8,60 [0,98 - 9,90]
Heating capacity at -7 °C		kW	3,33	4,07	4,30	5,00	6,13
COP <sup>1)</sup>	Nominal (Min - Max)	W/W	4,86 [5,15 - 4,12]	4,35 [5,15 - 3,63]	4,00 [4,45 - 3,37]	4,03 [2,88 - 3,20]	3,51 [2,45 - 3,47]
<b>SCOP<sup>2)</sup></b>			<b>4,50 A+</b>	<b>4,40 A+</b>	<b>4,30 A+</b>	<b>4,40 A+</b>	<b>4,00 A+</b>
Pdesign at -10 °C		kW	2,80	3,60	3,80	4,40	5,50
Input power heating	Nominal (Min - Max)	kW	0,70 [0,17 - 1,31]	0,92 [0,17 - 1,82]	1,35 [0,22 - 2,15]	1,44 [0,34 - 2,50]	2,45 [0,40 - 2,85]
Annual energy consumption <sup>3)</sup>		kWh/a	871	1145	1237	1400	1925
<b>Indoor unit</b>			<b>CS-Z25TKEA</b>	<b>CS-Z35TKEA</b>	<b>CS-Z42TKEA</b>	<b>CS-Z50TKEA</b>	<b>CS-Z71TKEA</b>
Power source		V	230	230	230	230	230
Recommended fuse		A	16	16	16	16	20
Connection indoor / outdoor		mm <sup>2</sup>	4 x 1,5	4 x 1,5	4 x 1,5	4 x 2,5	4 x 2,5
Air Volume	Cool / Heat	m <sup>3</sup> /min	10,4 / 11,7	10,7 / 12,4	18,2 / 20,2	19,2 / 21,3	20,2 / 21,0
Moisture removal volume		L/h	1,5	2,0	2,4	2,8	4,1
Sound pressure <sup>4)</sup>	Cool (Hi / Lo / Q-Lo)	dB(A)	39 / 25 / 21	42 / 28 / 21	43 / 32 / 29	44 / 37 / 30	47 / 38 / 35
	Heat (Hi / Lo / Q-Lo)	dB(A)	41 / 27 / 22	43 / 30 / 22	44 / 35 / 29	44 / 37 / 30	47 / 38 / 35
Dimension	H x W x D	mm	295 x 919 x 194	295 x 919 x 194	302 x 1120 x 236	302 x 1120 x 236	302 x 1120 x 236
Net weight		kg	9	10	12	12	13
<b>Outdoor unit</b>			<b>CU-Z25TKEA</b>	<b>CU-Z35TKEA</b>	<b>CU-Z42TKEA</b>	<b>CU-Z50TKEA</b>	<b>CU-Z71TKEA</b>
Sound pressure <sup>4)</sup>	Cool / Heat (Hi)	dB(A)	46 / 48	48 / 50	48 / 50	48 / 50	52 / 54
Dimension <sup>5)</sup>	H x W x D	mm	619 x 824 x 299	619 x 824 x 299	619 x 824 x 299	695 x 875 x 320	695 x 875 x 320
Net weight		kg	37	38	38	43	49
Piping connections	Liquid pipe	Inch (mm)	1/4 (6,35)	1/4 (6,35)	1/4 (6,35)	1/4 (6,35)	1/4 (6,35)
	Gas pipe	Inch (mm)	3/8 (9,52)	3/8 (9,52)	1/2 (12,70)	1/2 (12,70)	5/8 (15,88)
Pipe length range		m	3 ~ 20	3 ~ 20	3 ~ 20	3 ~ 30	3 ~ 30
Elevation difference (in/out) <sup>6)</sup>		m	15	15	15	15	20
Pipe length for additional gas		m	7,5	7,5	7,5	7,5	10
Additional gas amount		g/m	10	10	10	15	25
Refrigerant (R32) / CO <sub>2</sub> Eq.		kg / T	0,96 / 0,648	1,00 / 0,675	1,08 / 0,729	1,15 / 0,776	1,32 / 0,891
Operating range	Cool Min ~ Max	°C	-20 ~ +43	-20 ~ +43	-20 ~ +43	-20 ~ +43	-20 ~ +43
	Heat Min ~ Max	°C	-15 ~ +24	-15 ~ +24	-15 ~ +24	-15 ~ +24	-15 ~ +24

### Accessories

<b>CZ-TACG1*</b>	Panasonic Comfort Cloud for internet control
<b>CZ-CAPRA1*</b>	RAC interface adapter for integration into P-Link
<b>PAW-SERVER-PKEA*</b>	PCB for installation in server rooms with security
<b>PAW-WTRAY</b>	Tray for condenser water compatible with outdoor elevation platform

### Accessories

<b>PAW-GRDBSE20</b>	Outdoor base ground support for noise and vibration absorption
<b>PAW-GRDSTD40</b>	Outdoor elevation platform 400 x 900 x 400 mm

1) EER and COP calculation is based in accordance to EN14511. 2) Energy Label Scale from A+++ to D. 3) The annual energy consumption is calculated in accordance to EU/626/2011. 4) The sound pressure of the indoor unit shows the value measured at a position of 1 m in front of the main body and 0,8 m below the unit. For outdoor unit 1 m in front and 1 m in rear side of main body. The sound pressure is measured in accordance with JIS C 9612. Q-Lo: Quiet mode. Lo: The lowest set fan speed. 5) Add 70 mm for piping port. 6) When installing the outdoor unit at a higher position than the indoor unit.

\* Only one of these can be used at a time.



SEER and SCOP: For KIT-Z25-TKEA. SUPER QUIET: For KIT-Z25-TKEA. INTERNET CONTROL: Optional.



**CZ-BT20EW**  
RAL9010 panel for 4  
Way 60x60 Cassette.

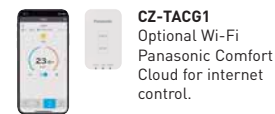

**CZ-TACG1**  
Optional Wi-Fi  
Panasonic Comfort  
Cloud for internet  
control.

#### 4 Way 60x60 Cassette Inverter • R32 refrigerant

KIT			KIT-Z25-UB4	KIT-Z35-UB4	KIT-Z50-UB4	KIT-Z60-UB4
Cooling capacity	Nominal (Min - Max)	kW	2,50 (0,85 - 3,20)	3,50 (0,85 - 4,00)	5,00 (0,90 - 5,80)	6,00 (0,90 - 6,35)
EER <sup>1)</sup>	Nominal (Min - Max)	W/W	4,55 (3,54 - 3,90)	3,89 (3,54 - 3,39)	3,25 (3,53 - 3,09)	2,93 (3,53 - 2,89)
<b>SEER <sup>2)</sup></b>			<b>6,30 A++</b>	<b>6,50 A++</b>	<b>6,40 A++</b>	<b>6,20 A++</b>
Pdesign (cooling)		kW	2,50	3,50	5,00	6,00
Input power cooling	Nominal (Min - Max)	kW	0,55 (0,24 - 0,82)	0,90 (0,24 - 1,18)	1,54 (0,26 - 1,88)	2,05 (0,26 - 2,20)
Annual energy consumption <sup>3)</sup>		kWh/a	139	188	273	339
Heating capacity	Nominal (Min - Max)	kW	3,20 (0,85 - 4,80)	4,50 (0,85 - 5,60)	5,60 (0,90 - 7,10)	7,00 (0,90 - 8,00)
Heating capacity at -7 °C		kW	2,88	3,37	4,40	5,10
COP <sup>1)</sup>	Nominal (Min - Max)	W/W	4,05 (3,70 - 3,64)	3,31 (3,70 - 3,20)	3,03 (3,46 - 2,95)	2,92 (3,46 - 2,91)
<b>SCOP <sup>2)</sup></b>			<b>4,30 A+</b>	<b>4,20 A+</b>	<b>4,30 A+</b>	<b>4,20 A+</b>
Pdesign at -10 °C		kW	2,70	3,00	3,80	4,00
Input power heating	Nominal (Min - Max)	kW	0,79 (0,23 - 1,32)	1,36 (0,23 - 1,75)	1,85 (0,26 - 2,41)	2,40 (0,26 - 2,75)
Annual energy consumption <sup>3)</sup>		kWh/a	879	1000	1237	1333
<b>Indoor unit</b>			<b>CS-Z25UB4EAW</b>	<b>CS-Z35UB4EAW</b>	<b>CS-Z50UB4EAW</b>	<b>CS-Z60UB4EAW</b>
<b>Panel</b>			<b>CZ-BT20EW</b>	<b>CZ-BT20EW</b>	<b>CZ-BT20EW</b>	<b>CZ-BT20EW</b>
Air volume	Cool / Heat	m <sup>3</sup> /min	10,5 / 10,8	10,5 / 10,8	11,5 / 11,8	12,4 / 13,5
Moisture removal volume		L/h	1,5	2,0	2,8	3,3
Sound pressure <sup>4)</sup>	Cool (Hi / Lo / Q-Lo)	dB(A)	34 / 25 / 22	34 / 26 / 23	37 / 28 / 25	42 / 32 / 29
	Heat (Hi / Lo / Q-Lo)	dB(A)	35 / 28 / 25	35 / 28 / 25	38 / 29 / 26	43 / 32 / 29
Dimension (HxWxD)	Indoor	mm	260x575x575	260x575x575	260x575x575	260x575x575
	Panel	mm	51x700x700	51x700x700	51x700x700	51x700x700
Net weight	Indoor / Panel	kg	18 / 2,5	18 / 2,5	18 / 2,5	18 / 2,5
<b>Outdoor unit</b>			<b>CU-Z25UBEA</b>	<b>CU-Z35UBEA</b>	<b>CU-Z50UBEA</b>	<b>CU-Z60UBEA</b>
Power source		V	230	230	230	230
Recommended fuse		A	—	—	—	—
Connection indoor / outdoor		mm <sup>2</sup>	—	—	—	—
Air volume	Cool / Heat	m <sup>3</sup> /min	28,7 / 27,2	34,3 / 33,5	39,7 / 38,6	42,6 / 41,5
Sound pressure <sup>4)</sup>	Cool / Heat (Hi)	dB(A)	46 / 47	48 / 48	48 / 48	49 / 50
Dimension <sup>5)</sup>	HxWxD	mm	542x780x289	619x824x299	695x875x320	695x875x320
Net weight		kg	33	35	43	43
Piping connections	Liquid pipe	Inch (mm)	1/4 (6,35)	1/4 (6,35)	1/4 (6,35)	1/4 (6,35)
	Gas pipe	Inch (mm)	3/8 (9,52)	3/8 (9,52)	1/2 (12,70)	1/2 (12,70)
Pipe length range		m	3 - 20	3 - 20	3 - 30	3 - 30
Elevation difference (in/out) <sup>6)</sup>		m	15	15	20	20
Pipe length for additional gas		m	7,5	7,5	7,5	7,5
Additional gas amount		g/m	10	10	15	15
Refrigerant (R32) / CO <sub>2</sub> Eq.		kg / T	0,88 / 0,594	0,93 / 0,628	1,13 / 0,763	1,13 / 0,763
Operating range	Cool Min ~ Max	°C	-10 ~ +43	-10 ~ +43	-10 ~ +43	-10 ~ +43
	Heat Min ~ Max	°C	-15 ~ +24	-15 ~ +24	-15 ~ +24	-15 ~ +24

#### Accessories

<b>CZ-TACG1</b>	Panasonic Comfort Cloud for internet control
<b>CZ-CAPRA1</b>	RAC interface adapter for integration into P-Link

#### Accessories

<b>CZ-RD52CP</b>	Wired remote controller for Cassette
------------------	--------------------------------------

1) EER and COP calculation is based in accordance to EN14511. 2) Energy Label Scale from A+++ to D. 3) The annual energy consumption is calculated in accordance to EU/626/2011. 4) The sound pressure of the indoor unit shows the value measured of a position of 1,5 m below the unit. For outdoor unit 1 m in front and 1 m in rear side of main body. The sound pressure is measured in accordance with JIS C 9612. Q-Lo: Quiet mode. Lo: The lowest set fan speed. 5) Add 70 mm for piping port. 6) When installing the outdoor unit at a higher position than the indoor unit.



SEER and SCOP: For KIT-Z35-UB4. SUPER QUIET: For KIT-Z25-UB4. INTERNET CONTROL: Optional.



**CZ-RL511D**  
Optional  
wireless kit.



**CZ-TACG1**  
Optional Wi-Fi  
Panasonic Comfort  
Cloud for internet  
control.

## Low Static Pressure Hide Away Inverter • R32 refrigerant

KIT			KIT-Z25-UD3	KIT-Z35-UD3	KIT-Z50-UD3	KIT-Z60-UD3
Cooling capacity	Nominal (Min - Max)	kW	2,50 (0,85 - 3,20)	3,50 (0,85 - 4,00)	5,10 (0,90 - 5,70)	6,00 (0,90 - 6,50)
EER <sup>1)</sup>	Nominal (Min - Max)	W/W	4,31 (3,54 - 3,76)	3,85 (3,54 - 3,36)	3,27 (3,53 - 3,20)	2,94 (3,53 - 2,83)
<b>SEER <sup>2)</sup></b>			<b>5,90 A+</b>	<b>5,80 A+</b>	<b>5,90 A+</b>	<b>5,60 A+</b>
Pdesign (cooling)		kW	2,50	3,50	5,10	6,00
Input power cooling	Nominal (Min - Max)	kW	0,58 (0,24 - 0,85)	0,91 (0,24 - 1,19)	1,56 (0,26 - 1,78)	2,04 (0,26 - 2,30)
Annual energy consumption <sup>3)</sup>		kWh/a	148	211	303	375
Heating capacity	Nominal (Min - Max)	kW	3,20 (0,85 - 4,60)	4,20 (0,85 - 5,10)	6,10 (0,90 - 7,20)	7,00 (0,90 - 8,00)
Heating capacity at -7 °C		kW	2,60	3,00	4,50	5,10
COP <sup>1)</sup>	Nominal (Min - Max)	W/W	4,00 (3,70 - 3,68)	3,82 (3,70 - 3,59)	3,35 (3,46 - 3,27)	3,24 (3,46 - 3,08)
<b>SCOP <sup>2)</sup></b>			<b>4,20 A+</b>	<b>4,10 A+</b>	<b>4,10 A+</b>	<b>4,10 A+</b>
Pdesign at -10 °C		kW	2,60	2,80	4,00	4,60
Input power heating	Nominal (Min - Max)	kW	0,80 (0,23 - 1,25)	1,10 (0,23 - 1,42)	1,82 (0,26 - 2,20)	2,16 (0,26 - 2,60)
Annual energy consumption <sup>3)</sup>		kWh/a	867	956	1366	1571
<b>Indoor unit</b>			<b>CS-Z25UD3EAW</b>	<b>CS-Z35UD3EAW</b>	<b>CS-Z50UD3EAW</b>	<b>CS-Z60UD3EAW</b>
External static pressure <sup>4)</sup>	Min - Max	Pa	15 - 45	15 - 45	15 - 50	15 - 50
Air volume	Cool / Heat	m <sup>3</sup> /min	10,5/10,5	11,2/11,2	15,3/15,3	15,7/15,7
Moisture removal volume		L/h	1,5	2,0	2,8	3,3
Sound pressure <sup>5)</sup>	Cool (Hi / Lo / Q-Lo)	dB(A)	33/27/24	33/27/24	39/29/26	41/30/27
	Heat (Hi / Lo / Q-Lo)	dB(A)	35/27/24	35/27/24	39/30/27	41/32/29
Dimension	HxWxD	mm	200 x 750 x 640	200 x 750 x 640	200 x 750 x 640	200 x 750 x 640
Net weight		kg	19	19	19	19
<b>Outdoor unit</b>			<b>CU-Z25UBEA</b>	<b>CU-Z35UBEA</b>	<b>CU-Z50UBEA</b>	<b>CU-Z60UBEA</b>
Power source		V	230	230	230	230
Recommended fuse		A	16	16	16	—
Connection indoor / outdoor		mm <sup>2</sup>	4 x 1,5 - 2,5	4 x 1,5 - 2,5	4 x 1,5 - 2,5	—
Air volume	Cool / Heat	m <sup>3</sup> /min	28,7/27,2	34,3/33,5	39,7/38,6	42,6/41,5
Sound pressure <sup>5)</sup>	Cool / Heat (Hi)	dB(A)	46/47	48/48	48/48	49/50
Dimension <sup>6)</sup>	HxWxD	mm	542 x 780 x 289	619 x 824 x 299	695 x 875 x 320	695 x 875 x 320
Net weight		kg	33	35	43	43
Piping connections	Liquid pipe	Inch (mm)	1/4 (6,35)	1/4 (6,35)	1/4 (6,35)	1/4 (6,35)
	Gas pipe	Inch (mm)	3/8 (9,52)	3/8 (9,52)	1/2 (12,70)	1/2 (12,70)
Pipe length range		m	3 - 20	3 - 20	3 - 30	3 - 30
Elevation difference (in/out) <sup>7)</sup>		m	15	15	20	20
Pipe length for additional gas		m	7,5	7,5	7,5	7,5
Additional gas amount		g/m	10	10	15	15
Refrigerant (R32) / CO <sub>2</sub> Eq.		kg / T	0,88/0,594	0,93/0,628	1,13/0,763	1,13/0,763
Operating range	Cool Min ~ Max	°C	-10 ~ +43	-10 ~ +43	-10 ~ +43	-10 ~ +43
	Heat Min ~ Max	°C	-15 ~ +24	-15 ~ +24	-15 ~ +24	-15 ~ +24

### Accessories

<b>CZ-TACG1</b>	Panasonic Comfort Cloud for internet control
<b>CZ-CAPRA1</b>	RAC interface adapter for integration into P-Link

### Accessories

<b>CZ-RD514C</b>	Wired remote controller for Wall-mounted and Floor Console
------------------	--

1) EER and COP calculation is based in accordance to EN14511. 2) Energy Label Scale from A+++ to D. 3) The annual energy consumption is calculated in accordance to EU/626/2011. 4) The specification listed on the table indicates values under the condition of 25Pa (2,5 mmAq) which are applied for factory default setting. Change switch on PCB from Hi to S-Hi to have more than 6,0 mmAq. 5) The sound pressure of the indoor unit shows the value measured of a position of 1,5 m below the unit with 1 m duct on the suction side and 2 m duct on the discharge side. For outdoor unit 1 m in front and 1 m in rear side of main body. The sound pressure is measured in accordance with JIS C 9612. 6) Add 100 mm for indoor unit or 70 mm for outdoor unit for piping port. 7) When installing the outdoor unit at a higher position than the indoor unit.



SEER and SCOP: For KIT-Z25-UD3. INTERNET CONTROL: Optional.



CZ-RTC5B

## PACi Elite Wall-mounted Inverter+ • R32 refrigerant

			Single Phase				
			3,6 kW	5,0 kW	6,0 kW	7,1 kW	9,0 kW
KIT			KIT-36PK2ZH5	KIT-50PK2ZH5	KIT-60PK2ZH5	KIT-71PK2ZH5	KIT-100PK2ZH5
Remote controller			CZ-RTC5B				
Cooling capacity	Nominal (Min - Max)	kW	3,6(1,5 - 4,0)	5,0(1,5 - 5,6)	6,1(2,0 - 7,1)	7,1(2,2 - 9,0)	9,5(3,1 - 10,5)
EER <sup>1)</sup>		W/W	4,90	4,10	3,86	3,50	3,26
<b>SEER <sup>2)</sup></b>			<b>8,0A++</b>	<b>7,6A++</b>	<b>7,2A++</b>	<b>6,8A++</b>	<b>6,4A++</b>
Pdesign		kW	3,6	5,0	6,1	7,1	9,5
Input power cooling		kW	0,74	1,22	1,58	2,03	2,91
Annual energy consumption <sup>3)</sup>		kWh/a	157	230	297	365	520
Heating capacity	Nominal (Min - Max)	kW	4,0(1,5 - 5,0)	5,6(1,5 - 6,5)	7,0(1,8 - 8,0)	8,0(2,0 - 9,0)	9,5(3,1 - 11,5)
COP <sup>1)</sup>		W/W	4,94	4,21	4,46	4,00	3,97
<b>SCOP <sup>2)</sup></b>			<b>4,9A++</b>	<b>4,7A++</b>	<b>4,8A++</b>	<b>4,7A++</b>	<b>4,1A+</b>
Pdesign at -10 °C		kW	3,6	4,5	6,0	5,2	8,0
Input power heating		kW	0,81	1,33	1,57	2,00	2,39
Annual energy consumption <sup>3)</sup>		kWh/a	1029	1340	1750	1549	2732
Indoor unit			S-36PK2E5B	S-50PK2E5B	S-60PK2E5B	S-71PK2E5B	S-100PK2E5B
Air volume	Hi / Med / Lo	m <sup>3</sup> /min	13,0/11,0/9,0	16,0/14,0/11,0	20,0/18,0/15,0	20,0/17,5/14,5	22,0/18,5/15,0
Sound pressure <sup>4)</sup>	Hi / Med / Lo	dB(A)	35/31/27	40/36/32	47/44/40	47/44/40	49/45/41
Dimension	HxWxD	mm	302x1120x236	302x1120x236	302x1120x236	302x1120x236	302x1120x236
Net weight		kg	13	13	14	14	14
Outdoor unit			U-36PZH2E5	U-50PZH2E5	U-60PZH2E5	U-71PZH2E5	U-100PZH2E5
Power source		V	220 - 230 - 240	220 - 230 - 240	220 - 230 - 240	220 - 230 - 240	220 - 230 - 240
Current	Cool	A	3,55 - 3,40 - 3,25	5,70 - 5,50 - 5,25	7,70 - 7,35 - 7,05	9,55 - 9,10 - 8,75	13,50 - 12,90 - 12,40
	Heat	A	3,95 - 3,75 - 3,60	6,35 - 6,05 - 5,80	7,65 - 7,30 - 7,00	9,20 - 8,80 - 8,50	11,10 - 10,60 - 10,10
Air volume	Cool / Heat	m <sup>3</sup> /min	40/40	40/45	40/45	61/60	118/108
Sound pressure	Cool / Heat (Hi)	dB(A)	43/44	45/48	46/49	48/50	52/52
Sound power	Cool / Heat (Hi)	dB(A)	62/64	64/68	65/69	65/67	69/69
Dimension	HxWxD	mm	695x875x320	695x875x320	695x875x320	996x940x340	1416x940x340
Net weight		kg	43	43	44	68	99
Piping connections	Liquid pipe	Inch (mm)	1/4(6,35)	1/4(6,35)	3/8(9,52)	3/8(9,52)	3/8(9,52)
	Gas pipe	Inch (mm)	1/2(12,70)	1/2(12,70)	5/8(15,88)	5/8(15,88)	5/8(15,88)
Pipe length range		m	3 - 40	3 - 40	3 - 40	5 - 50	5 - 85
Elevation difference (in/out) <sup>5)</sup>		m	30	30	30	30	30
Pipe length for additional gas		m	30	30	30	30	30
Additional gas amount		g/m	20	20	35	45	45
Refrigerant (R32) / CO <sub>2</sub> Eq.		kg / T	1,15/0,776	1,15/0,776	1,45/0,979	1,95/1,316	3,05/2,059
Operating range	Cool Min ~ Max	°C	-15 ~ +46	-15 ~ +46	-15 ~ +46	-15 ~ +46	-20 <sup>6)</sup> ~ +46
	Heat Min ~ Max	°C	-20 ~ +24	-20 ~ +24	-20 ~ +24	-20 ~ +24	-20 ~ +24

### Accessories

<b>CZ-RTC6</b>	<b>NEW</b> Wired remote controller (non-wireless)
<b>CZ-RTC6BL</b>	<b>NEW</b> Wired remote controller with Bluetooth®
<b>CZ-RTC5B</b>	Wired remote controller with Econavi function and datanavi
<b>CZ-RWS3</b>	Infrared remote controller
<b>CZ-CAPWFC1</b>	Commercial Wi-Fi Adaptor
<b>PAW-PACR3</b>	Interfaces to run 3 units on Backup and alternative run

### Accessories

<b>PAW-WTRAY</b>	Tray for condenser water compatible with outdoor elevation platform
<b>PAW-GRDBSE20</b>	Outdoor base ground support for noise and vibration absorption
<b>PAW-GRDSTD40</b>	Outdoor elevation platform 400x900x400 mm
<b>CZ-CENSC1</b>	Econavi energy savings sensor



**CZ-RTC6**  
**CZ-RTC6BL**  
Optional Controller.  
Wired remote controller.



**CZ-RWS3**  
Optional Controller.  
Infrared remote controller.



**CZ-CENSC1**  
Optional Econavi  
Sensor.



## PACi Elite Wall-mounted Inverter+ • R32 refrigerant

### Three Phase

			7,1 kW	9,0 kW
KIT			KIT-71PK2ZH8	KIT-100PK2ZH8
Remote controller			CZ-RTC5B	CZ-RTC5B
Cooling capacity	Nominal (Min - Max)	kW	7,1 (2,2 - 9,0)	9,5 (3,1 - 10,5)
EER <sup>1)</sup>		W/W	3,50	3,26
<b>SEER <sup>2)</sup></b>			<b>6,7 A++</b>	<b>6,3 A++</b>
Pdesign		kW	7,10	9,50
Input power cooling		kW	2,03	2,91
Annual energy consumption <sup>3)</sup>		kWh/a	370	526
Heating capacity	Nominal (Min - Max)	kW	8,0 (2,0 - 9,0)	9,5 (3,1 - 11,5)
COP <sup>1)</sup>		W/W	4,00	3,97
<b>SCOP <sup>2)</sup></b>			<b>4,7 A++</b>	<b>4,1 A+</b>
Pdesign at -10 °C		kW	5,20	8,00
Input power heating		kW	2,00	2,39
Annual energy consumption <sup>3)</sup>		kWh/a	1549	2732
Indoor unit			S-71PK2E5B	S-100PK2E5B
Air volume	Hi / Med / Lo	m <sup>3</sup> /min	20,0/17,5/14,5	22,0/18,5/15,0
Sound pressure <sup>4)</sup>	Hi / Med / Lo	dB(A)	47/44/40	49/45/41
Dimension	HxWxD	mm	302x1120x236	302x1120x236
Net weight		kg	14	14
Outdoor unit			U-71PZH2E8	U-100PZH2E8
Power source		V	380 - 400 - 415	380 - 400 - 415
Current	Cool	A	3,20 - 3,05 - 2,95	4,60 - 4,35 - 4,20
	Heat	A	3,10 - 3,00 - 2,85	3,75 - 3,55 - 3,45
Air volume	Cool / Heat	m <sup>3</sup> /min	61/60	118/108
Sound pressure	Cool / Heat (Hi)	dB(A)	48/50	52/52
Sound power	Cool / Heat (Hi)	dB(A)	65/67	69/69
Dimension	HxWxD	mm	996 x 940 x 340	1416 x 940 x 340
Net weight		kg	68	99
Piping connections	Liquid pipe	Inch (mm)	3/8 (9,52)	3/8 (9,52)
	Gas pipe	Inch (mm)	5/8 (15,88)	5/8 (15,88)
Pipe length range		m	5 - 50	5 - 85
Elevation difference (in/out) <sup>5)</sup>		m	30	30
Pipe length for additional gas		m	30	30
Additional gas amount		g/m	45	45
Refrigerant (R32) / CO <sub>2</sub> Eq.		kg / T	1,95 / 1,316	3,05 / 2,059
Operating range	Cool Min ~ Max	°C	-15 ~ +46	-20 <sup>6)</sup> ~ +46
	Heat Min ~ Max	°C	-20 ~ +24	-20 ~ +24

1) EER and COP calculation is based in accordance to EN14511. 2) Energy Label Scale from A+++ to D. For models below 12 kW, the SEER and SCOP is calculated based on values of EU/626/2011. For models above 12 kW, the SEER and SCOP is calculated based on values of EU/2281/2016. 3) The annual energy consumption is calculated in accordance to EU/626/2011. 4) The sound pressure of the units shows the value measured of the position 1 m in front of the main body and 1 m below the unit. The sound pressure is measured in accordance with Eurovent 6/C/006-97 specification. 5) When installing the outdoor unit at a higher position than the indoor unit. 6) For models 100 - 140PZH2E5(8), it is possible to operate the lowest -20 °C in the computer rooms with the piping length of 30 m or less. \* Recommended fuse for the indoor 3 A.



SEER and SCOP: For KIT-36PK2ZH5. INTERNET CONTROL: Optional.

Compatible with all Panasonic connectivity solutions. For detailed information go to the Control Systems section.



CZ-RTC5B

## PACi Standard Wall-mounted Inverter+ • R32 refrigerant

			Single Phase		
			6,0 kW	7,1 kW	9,0 kW
KIT			KIT-60PK2Z5	KIT-71PK2Z5	KIT-100PK2Z5
Remote controller			CZ-RTC5B	CZ-RTC5B	CZ-RTC5B
Cooling capacity	Nominal (Min - Max)	kW	6,1 (2,0 - 7,1)	7,1 (2,0 - 7,7)	9,0 (3,0 - 9,7)
EER <sup>1)</sup>	Nominal (Min - Max)	W/W	3,79	3,21	3,47 (5,36 - 3,13)
<b>SEER <sup>2)</sup></b>			<b>6,8 A++</b>	<b>6,4 A++</b>	<b>6,5 A++</b>
Pdesign		kW	6,1	7,1	9,0
Input power cooling	Nominal (Min - Max)	kW	1,61	2,21	2,59 (0,56 - 3,10)
Annual energy consumption <sup>3)</sup>		kWh/a	314	388	485
Heating capacity	Nominal (Min - Max)	kW	6,1 (1,8 - 7,0)	7,1 (1,8 - 8,1)	9,0 (3,0 - 10,5)
COP <sup>1)</sup>	Nominal (Min - Max)	W/W	4,80	4,41	3,93 (5,36 - 3,56)
<b>SCOP <sup>2)</sup></b>			<b>4,7 A++</b>	<b>4,6 A++</b>	<b>3,9 A</b>
Pdesign at -10 °C		kW	6,0	6,0	9,0
Input power heating	Nominal (Min - Max)	kW	1,27	1,61	2,29 (0,56 - 2,95)
Annual energy consumption <sup>3)</sup>		kWh/a	1787	1826	3231
Indoor unit			S-60PK2E5B	S-71PK2E5B	S-100PK2E5B
Air volume	Hi / Med / Lo	m <sup>3</sup> /min	20,0/18,0/15,0	20,0/18,0/15,0	22,0/18,5/15,0
Moisture removal volume		L/h	2,0	3,0	4,3
Sound pressure <sup>4)</sup>	Hi / Med / Lo	dB(A)	47/44/40	47/44/40	49/45/41
Sound power	Hi / Med / Lo	dB(A)	63/60/56	63/60/56	65/61/57
Dimension	H x W x D	mm	302 x 1120 x 236	302 x 1120 x 236	302 x 1120 x 236
Net weight		kg	14	14	14
Outdoor unit			U-60PZ2E5	U-71PZ2E5	U-100PZ2E5
Power source		V	220 - 230 - 240	220 - 230 - 240	220 - 230 - 240
Current	Cool	A	7,85 - 7,50 - 7,20	10,70 - 10,20 - 9,85	12,10 - 11,50 - 11,10
	Heat	A	6,10 - 5,85 - 5,60	7,85 - 7,50 - 7,20	10,60 - 10,20 - 9,70
Air volume	Cool / Heat	m <sup>3</sup> /min	40/45	50/45	76/70
Sound pressure	Cool / Heat (Hi)	dB(A)	46/48	49/49	52/52
Sound power	Cool / Heat (Hi)	dB(A)	65/68	69/69	70/70
Dimension	H x W x D	mm	695 x 875 x 320	695 x 875 x 320	996 x 980 x 370
Net weight		kg	44	44	90
Piping connections	Liquid pipe	Inch (mm)	3/8 (9,52)	3/8 (9,52)	3/8 (9,52)
	Gas pipe	Inch (mm)	5/8 (15,88)	5/8 (15,88)	5/8 (15,88)
Pipe length range		m	3 - 40	3 - 40	5 - 50
Elevation difference (in/out) <sup>5)</sup>		m	30	30	30
Pipe length for additional gas		m	30	30	30
Additional gas amount		g/m	35	35	45
Refrigerant (R32) / CO <sub>2</sub> Eq.		kg / T	1,45/0,979	1,45/0,979	2,60/1,755
Operating range	Cool Min ~ Max	°C	-10 ~ +43	-10 ~ +43	-10 ~ +43
	Heat Min ~ Max	°C	-15 ~ +24	-15 ~ +24	-15 ~ +24

### Accessories

<b>CZ-RTC6</b>	<b>NEW</b> Wired remote controller (non-wireless)
<b>CZ-RTC6BL</b>	<b>NEW</b> Wired remote controller with Bluetooth®
<b>CZ-RTC5B</b>	Wired remote controller with Econavi function and datanavi
<b>CZ-RWS3</b>	Infrared remote controller
<b>CZ-CAPWFC1</b>	Commercial Wi-Fi Adaptor
<b>PAW-PACR3</b>	Interfaces to run 3 units on Backup and alternative run

### Accessories

<b>PAW-WTRAY</b>	Tray for condenser water compatible with outdoor elevation platform
<b>PAW-GRDBSE20</b>	Outdoor base ground support for noise and vibration absorption
<b>PAW-GRDSTD40</b>	Outdoor elevation platform 400 x 900 x 400 mm
<b>CZ-CENSC1</b>	Econavi energy savings sensor



**CZ-RTC6**  
**CZ-RTC6BL**  
Optional Controller.  
Wired remote controller.



**CZ-RWS3**  
Optional Controller.  
Infrared remote controller.



**CZ-CENSC1**  
Optional Econavi  
Sensor.



## PACi Standard Wall-mounted Inverter+ • R32 refrigerant

			Three Phase
			9,0 kW
<b>KIT</b>			<b>KIT-100PK2Z8</b>
<b>Remote controller</b>			<b>CZ-RTC5B</b>
Cooling capacity	Nominal (Min - Max)	kW	9,0 (3,0 - 9,7)
EER <sup>1)</sup>	Nominal (Min - Max)	W/W	3,47 (5,36 - 3,13)
<b>SEER <sup>2)</sup></b>			<b>6,5A++</b>
Pdesign		kW	9,0
Input power cooling	Nominal (Min - Max)	kW	2,59 (0,56 - 3,10)
Annual energy consumption <sup>3)</sup>		kWh/a	485
Heating capacity	Nominal (Min - Max)	kW	9,0 (3,0 - 10,5)
COP <sup>1)</sup>	Nominal (Min - Max)	W/W	3,93 (5,36 - 3,56)
<b>SCOP <sup>2)</sup></b>			<b>3,9A</b>
Pdesign at -10 °C		kW	9,0
Input power heating	Nominal (Min - Max)	kW	2,29 (0,56 - 2,95)
Annual energy consumption <sup>3)</sup>		kWh/a	3231
<b>Indoor unit</b>			<b>S-100PK2E5B</b>
Air volume	Hi / Med / Lo	m <sup>3</sup> /min	22,0 / 18,5 / 15,0
Moisture removal volume		L/h	4,3
Sound pressure <sup>4)</sup>	Hi / Med / Lo	dB(A)	49 / 45 / 41
Sound power	Hi / Med / Lo	dB(A)	65 / 61 / 57
Dimension	H x W x D	mm	302 x 1120 x 236
Net weight		kg	14
<b>Outdoor unit</b>			<b>U-100PZ2E8</b>
Power source		V	380 - 400 - 415
Current	Cool	A	4,10 - 3,90 - 3,75
	Heat	A	3,60 - 3,45 - 3,30
Air volume	Cool / Heat	m <sup>3</sup> /min	76 / 70
Sound pressure	Cool / Heat (Hi)	dB(A)	52 / 52
Sound power	Cool / Heat (Hi)	dB(A)	70 / 70
Dimension	H x W x D	mm	996 x 980 x 370
Net weight		kg	90
Piping connections	Liquid pipe	Inch (mm)	3/8 (9,52)
	Gas pipe	Inch (mm)	5/8 (15,88)
Pipe length range		m	5 - 50
Elevation difference (in/out) <sup>5)</sup>		m	30
Pipe length for additional gas		m	30
Additional gas amount		g/m	45
Refrigerant (R32) / CO <sub>2</sub> Eq.		kg / T	2,60 / 1,755
Operating range	Cool Min ~ Max	°C	-10 ~ +43
	Heat Min ~ Max	°C	-15 ~ +24

1) EER and COP calculation is based in accordance to EN14511. 2) Energy Label Scale from A+++ to D. For models below 12 kW, the SEER and SCOP is calculated based on values of EU/626/2011. For models above 12 kW, the SEER and SCOP is calculated based on values of EU/2281/2016. 3) The annual energy consumption is calculated in accordance to EU/626/2011. 4) The sound pressure of the units shows the value measured of the position 1 m in front of the main body and 1 m below the unit. The sound pressure is measured in accordance with Eurovent 6/C/006-97 specification. 5) When installing the outdoor unit at a higher position than the indoor unit. \* Recommended fuse for the indoor 3 A.



SEER and SCOP: For KIT-60PK2Z5. INTERNET CONTROL: Optional.  
Compatible with all Panasonic connectivity solutions. For detailed information go to the Control Systems section.



CZ-RTC5B

**CZ-KPY3AW**  
Panel 700 x 700 mm.

**CZ-KPY3BW**  
Panel 625 x 625 mm.



**CZ-RTC6**  
**CZ-RTC6BL**  
Optional Controller.  
Wired remote controller.



**CZ-RWS3**  
Optional Controller.  
Infrared remote controller.



## PACi Elite 4 Way 60x60 Cassette Inverter+ • R32 refrigerant

			Single Phase	
			3,6 kW	5,0 kW
KIT			KIT-36PY2ZH5	KIT-50PY2ZH5
Remote controller			CZ-RTC5B	CZ-RTC5B
Cooling capacity	Nominal (Min - Max)	kW	3,6 (1,5 - 4,0)	5,0 (1,5 - 5,6)
EER <sup>1)</sup>		W/W	4,68	3,68
<b>SEER <sup>2)</sup></b>			<b>6,6 A++</b>	<b>6,4 A++</b>
Pdesign		kW	3,6	5,0
Input power cooling		kW	0,77	1,36
Annual energy consumption <sup>3)</sup>		kWh/a	191	273
Heating capacity	Nominal (Min - Max)	kW	4,0 (1,5 - 5,0)	5,6 (1,5 - 6,5)
COP <sup>1)</sup>		W/W	4,26	3,46
<b>SCOP <sup>2)</sup></b>			<b>4,6 A++</b>	<b>4,3 A+</b>
Pdesign at -10 °C		kW	3,6	4,5
Input power heating		kW	0,94	1,62
Annual energy consumption <sup>3)</sup>		kWh/a	1096	1465
Indoor unit			S-36PY2E5B	S-50PY2E5B
Air volume	Hi / Med / Lo	m <sup>3</sup> /min	9,7/8,0/6,0	11,1/9,8/8,5
Moisture removal volume		L/h	1,5	2,4
Sound pressure <sup>4)</sup>	Hi / Med / Lo	dB(A)	36/32/26	40/37/33
Sound power	Hi / Med / Lo	dB(A)	51/47/41	55/52/48
Dimension (HxWxD) / Net weight	Indoor	mm / kg	288 x 583 x 583 / 18	288 x 583 x 583 / 18
	CZ-KPY3AW Panel	mm / kg	31 x 700 x 700 / 2,4	31 x 700 x 700 / 2,4
	CZ-KPY3BW Panel	mm / kg	31 x 625 x 625 / 2,4	31 x 625 x 625 / 2,4
Outdoor unit			U-36PZH2E5	U-50PZH2E5
Power source		V	220 - 230 - 240	220 - 230 - 240
Current	Cool	A	3,65 - 3,50 - 3,35	6,35 - 6,10 - 5,85
	Heat	A	4,50 - 4,30 - 4,15	7,70 - 8,40 - 8,10
Air volume	Cool / Heat	m <sup>3</sup> /min	40/40	40/45
Sound pressure	Cool / Heat (Hi)	dB(A)	43/44	45/48
Sound power	Cool / Heat (Hi)	dB(A)	62/64	64/68
Dimension / Net weight	HxWxD	mm / kg	695 x 875 x 320 / 43	695 x 875 x 320 / 43
Piping connections	Liquid pipe	Inch (mm)	1/4 (6,35)	1/4 (6,35)
	Gas pipe	Inch (mm)	1/2 (12,70)	1/2 (12,70)
Pipe length range		m	3 - 40	3 - 40
Elevation difference (in/out) <sup>5)</sup>		m	30	30
Pipe length for additional gas		m	30	30
Additional gas amount		g/m	20	20
Refrigerant (R32) / CO <sub>2</sub> Eq.		kg / T	1,15/0,776	1,15/0,776
Operating range	Cool Min ~ Max	°C	-15 ~ +46	-15 ~ +46
	Heat Min ~ Max	°C	-20 ~ +24	-20 ~ +24

### Accessories

<b>CZ-RTC6</b>	<b>NEW</b> Wired remote controller (non-wireless)
<b>CZ-RTC6BL</b>	<b>NEW</b> Wired remote controller with Bluetooth®
<b>CZ-RTC5B</b>	Wired remote controller with Econavi function and datanavi
<b>CZ-RWS3</b>	Infrared remote controller
<b>CZ-CAPWFC1</b>	Commercial Wi-Fi Adaptor

### Accessories

<b>PAW-WTRAY</b>	Tray for condenser water compatible with outdoor elevation platform
<b>PAW-GRDBSE20</b>	Outdoor base ground support for noise and vibration absorption
<b>PAW-GRDSTD40</b>	Outdoor elevation platform 400 x 900 x 400 mm
<b>CZ-CENSC1</b>	Econavi energy savings sensor



SEER and SCOP: For KIT-36PY2ZH5. INTERNET CONTROL: Optional.

Compatible with all Panasonic connectivity solutions. For detailed information go to the Control Systems section.



### PACi Standard 4 Way 60x60 Cassette Inverter+ • R32 refrigerant

		3,6 kW		4,5 kW		5,0 kW		
Indoor unit		S-36PY2E5B		S-45PY2E5B <sup>1)</sup>		S-50PY2E5B		
Cooling capacity	kW	3,6		4,5		5,0		
Heating capacity	kW	4,0		5,2		5,6		
Current	Cool	A	0,30	0,32	0,35			
	Heat	A	0,30	0,30	0,35			
Input power	Cool	kW	0,04	0,04	0,05			
	Heat	kW	0,04	0,04	0,04			
Air volume	Cool (Hi / Med / Lo)	m <sup>3</sup> /min	9,7/8,0/6,0	10,0/8,8/7,0	11,1/9,8/8,5			
	Heat (Hi / Med / Lo)	m <sup>3</sup> /min	9,9/8,2/6,0	10,3/9,2/7,0	11,1/9,8/8,7			
Moisture removal volume	L/h	1,5		2,2		2,4		
Sound pressure <sup>4)</sup>	Cool (Hi / Med / Lo)	dB(A)	36/32/26	38/34/28	40/37/33			
	Heat (Hi / Med / Lo)	dB(A)	36/32/26	38/34/28	40/37/33			
Sound power	Cool (Hi / Med / Lo)	dB(A)	51/47/41	53/49/43	55/52/48			
	Heat (Hi / Med / Lo)	dB(A)	51/47/41	53/49/43	55/52/48			
Dimension (HxWxD)	Indoor	mm	288 x 583 x 583		288 x 583 x 583		288 x 583 x 583	
	Panel CZ-KPY3AW	mm	31 x 700 x 700		31 x 700 x 700		31 x 700 x 700	
	Panel CZ-KPY3BW	mm	31 x 625 x 625		31 x 625 x 625		31 x 625 x 625	
Net weight	Indoor	kg	18		18		18	
	Panel	kg	2,4		2,4		2,4	
Piping connections	Liquid pipe	Inch (mm)	1/4 (6,35)		1/4 (6,35)		1/4 (6,35)	
	Gas pipe	Inch (mm)	1/2 (12,70)		1/2 (12,70)		1/2 (12,70)	
Operating range	Cool Min ~ Max	°C	+18 ~ +32		+18 ~ +32		+18 ~ +32	
	Heat Min ~ Max	°C	+16 ~ +30		+16 ~ +30		+16 ~ +30	

1) Only for multi combinations.  
Recommended fuse for the indoor 3 A.



1) EER and COP calculation is based in accordance to EN14511. 2) Energy Label Scale from A+++ to D. For models below 12 kW, the SEER and SCOP is calculated based on values of EU/626/2011. For models above 12 kW, the SEER and SCOP is calculated based on values of EU/2281/2016. 3) The annual energy consumption is calculated in accordance to EU/626/2011. 4) The sound pressure of the units shows the value measured of the position 1,5 m below the unit. The sound pressure is measured in accordance with Eurovent 6/C/006-97 specification. 5) When installing the outdoor unit at a higher position than the indoor unit. \* Recommended fuse for the indoor 3 A.



CZ-RTC5B

CZ-KPU3W  
Standard panel.CZ-KPU3AW  
Optional Econavi  
panel (CZ-RTC5B is  
required).

  
CZ-CNEXU1  
Optional  
nanoe X Generator  
Mark 1 kit (CZ-RTC5B  
is required).

## PACi Elite 4 Way 90x90 Cassette Inverter+ • R32 refrigerant

			Single Phase							
			3,6 kW	5,0 kW	6,0 kW	7,1 kW	10,0 kW	12,5 kW	14,0 kW	
KIT			KIT-36PU2ZH5	KIT-50PU2ZH5	KIT-60PU2ZH5	KIT-71PU2ZH5	KIT-100PU2ZH5	KIT-125PU2ZH5	KIT-140PU2ZH5	
Remote controller			CZ-RTC5B	CZ-RTC5B	CZ-RTC5B	CZ-RTC5B	CZ-RTC5B	CZ-RTC5B	CZ-RTC5B	
Cooling capacity	Nominal (Min - Max)	kW	3,6(1,5 - 4,0)	5,0(1,5 - 5,6)	6,0(2,0 - 7,1)	7,1(2,2 - 9,0)	10,0(3,1 - 12,5)	12,5(3,2 - 14,0)	14,0(3,3 - 16,0)	
EER <sup>1)</sup>		W/W	5,22	4,31	4,05	4,06	4,41	3,80	3,41	
SEER <sup>2)</sup>			<b>8,5A+++</b>	<b>8,2A++</b>	<b>8,0A++</b>	<b>7,7A++</b>	<b>7,8A++</b>	<b>7,7</b>	<b>7,2</b>	
Pdesign		kW	3,6	5,0	6,0	7,1	10,0	12,5	14,0	
Input power cooling		kW	0,69	1,16	1,48	1,75	2,27	3,29	4,11	
Annual energy consumption <sup>3)</sup>		kWh/a	148	213	262	323	449	—	—	
Heating capacity	Nominal (Min - Max)	kW	4,0(1,5 - 5,0)	5,6(1,5 - 6,5)	7,0(1,8 - 8,0)	8,0(2,0 - 9,0)	11,2(3,1 - 14,0)	14,0(3,2 - 16,0)	16,0(3,3 - 18,0)	
COP <sup>1)</sup>		W/W	5,48	4,71	4,29	4,30	5,00	4,61	4,30	
SCOP <sup>2)</sup>			<b>5,1A+++</b>	<b>4,9A++</b>	<b>4,8A++</b>	<b>4,8A++</b>	<b>4,9A++</b>	<b>4,7</b>	<b>4,6</b>	
Pdesign at -10 °C		kW	3,6	4,5	6,0	5,2	8,0	9,5	10,6	
Input power heating		kW	0,73	1,19	1,63	1,86	2,24	3,04	3,72	
Annual energy consumption <sup>3)</sup>		kWh/a	988	1286	1750	1517	2286	—	—	
Indoor unit			S-36PU2E5B	S-50PU2E5B	S-60PU2E5B	S-71PU2E5B	S-100PU2E5B	S-125PU2E5B	S-140PU2E5B	
Air volume	Hi / Med / Lo	m <sup>3</sup> /min	14,5/13,0/11,5	16,5/13,5/11,5	21,0/16,0/13,0	22,0/16,0/13,0	36,0/26,0/18,0	37,0/27,0/19,0	38,0/29,0/20,0	
Sound pressure <sup>4)</sup>	Hi / Med / Lo	dB(A)	30/28/27	32/29/27	36/31/28	37/31/28	45/38/32	46/39/33	47/40/34	
Dimension	Indoor (H x W x D)	mm	256 x 840 x 840	256 x 840 x 840	256 x 840 x 840	256 x 840 x 840	319 x 840 x 840	319 x 840 x 840	319 x 840 x 840	
	Panel (H x W x D)	mm	33,5 x 950 x 950	33,5 x 950 x 950	33,5 x 950 x 950	33,5 x 950 x 950	33,5 x 950 x 950	33,5 x 950 x 950	33,5 x 950 x 950	
Net weight	Indoor / Panel	kg	19/5	19/5	20/5	20/5	25/5	25/5	25/5	
Outdoor unit			U-36PZH2E5	U-50PZH2E5	U-60PZH2E5	U-71PZH2E5	U-100PZH2E5	U-125PZH2E5	U-140PZH2E5	
Power source		V	220 - 230 - 240	220 - 230 - 240	220 - 230 - 240	220 - 230 - 240	220 - 230 - 240	220 - 230 - 240	220 - 230 - 240	
Current	Cool	A	3,35 - 3,20 - 3,05	5,45 - 5,25 - 5,00	7,30 - 6,95 - 6,70	8,25 - 7,90 - 7,55	10,40 - 9,95 - 9,50	15,20 - 14,50 - 13,90	19,10 - 18,20 - 17,50	
	Heat	A	3,55 - 3,40 - 3,25	5,70 - 5,45 - 5,20	8,05 - 7,70 - 7,40	8,60 - 8,25 - 8,00	10,20 - 9,80 - 9,40	14,00 - 13,40 - 12,80	17,20 - 16,50 - 15,80	
Air volume	Cool / Heat	m <sup>3</sup> /min	40/40	40/45	40/45	61/60	118/108	125/122	129/116	
Sound pressure	Cool / Heat (Hi)	dB(A)	43/44	45/48	46/49	48/50	52/52	53/53	54/54	
Sound power	Cool / Heat (Hi)	dB(A)	62/64	64/68	65/69	65/67	69/69	70/70	71/71	
Dimension	H x W x D	mm	695 x 875 x 320	695 x 875 x 320	695 x 875 x 320	996 x 940 x 340	1416 x 940 x 340	1416 x 940 x 340	1416 x 940 x 340	
Net weight		kg	43	43	44	68	99	99	99	
Piping connections	Liquid pipe	Inch (mm)	1/4(6,35)	1/4(6,35)	3/8(9,52)	3/8(9,52)	3/8(9,52)	3/8(9,52)	3/8(9,52)	
	Gas pipe	Inch (mm)	1/2(12,70)	1/2(12,70)	5/8(15,88)	5/8(15,88)	5/8(15,88)	5/8(15,88)	5/8(15,88)	
Pipe length range		m	3 - 40	3 - 40	3 - 40	5 - 50	5 - 85	5 - 85	5 - 85	
Elevation difference (in/out) <sup>5)</sup>		m	30	30	30	30	30	30	30	
Pipe length for additional gas		m	30	30	30	30	30	30	30	
Additional gas amount		g/m	20	20	35	45	45	45	45	
Refrigerant (R32) / CO <sub>2</sub> Eq.		kg / T	1,15/0,776	1,15/0,776	1,45/0,979	1,95/1,316	3,05/2,059	3,05/2,059	3,05/2,059	
Operating range	Cool Min ~ Max	°C	-15 ~ +46	-15 ~ +46	-15 ~ +46	-15 ~ +46	-20 <sup>6)</sup> ~ +46	-20 <sup>6)</sup> ~ +46	-20 <sup>6)</sup> ~ +46	
	Heat Min ~ Max	°C	-20 ~ +24	-20 ~ +24	-20 ~ +24	-20 ~ +24	-20 ~ +24	-20 ~ +24	-20 ~ +24	

### Accessories

<b>CZ-RTC6</b>	<b>NEW</b> Wired remote controller (non-wireless)
<b>CZ-RTC6BL</b>	<b>NEW</b> Wired remote controller with Bluetooth®
<b>CZ-RTC5B</b>	Wired remote controller with Econavi function and datanavi
<b>CZ-RWS3 + CZ-RRWU3W</b>	Infrared remote controller
<b>CZ-CAPWFC1</b>	Commercial Wi-Fi Adaptor
<b>CZ-KPU3AW</b>	Econavi exclusive panel

### Accessories

<b>CZ-CNEXU1</b>	nanoe X Generator Mark 1 kit
<b>PAW-WTRAY</b>	Tray for condenser water compatible with outdoor elevation platform
<b>PAW-GRDBSE20</b>	Outdoor base ground support for noise and vibration absorption
<b>PAW-GRDSTD40</b>	Outdoor elevation platform 400 x 900 x 400 mm
<b>CZ-CENSC1</b>	Econavi energy savings sensor



**CZ-RTC6**  
**CZ-RTC6BL**  
Optional Controller.  
Wired remote controller.



**CZ-RWS3 +**  
**CZ-RWRU3W**  
Optional Controller.  
Infrared remote controller.



## PACi Elite 4 Way 90x90 Cassette Inverter+ • R32 refrigerant

### Three Phase

			7,1 kW	10,0 kW	12,5 kW	14,0 kW
KIT			KIT-71PU2ZH8	KIT-100PU2ZH8	KIT-125PU2ZH8	KIT-140PU2ZH8
Remote controller			CZ-RTC5B	CZ-RTC5B	CZ-RTC5B	CZ-RTC5B
Cooling capacity	Nominal (Min - Max)	kW	7,1 [2,2 - 9,0]	10,0 [3,1 - 12,5]	12,5 [3,2 - 14,0]	14,0 [3,3 - 16,0]
EER <sup>1)</sup>		W/W	4,06	4,41	3,80	3,41
SEER <sup>2)</sup>			<b>7,6 A++</b>	<b>7,7 A++</b>	<b>7,6</b>	<b>7,2</b>
Pdesign		kW	7,1	10,0	12,5	14,0
Input power cooling		kW	1,75	2,27	3,29	4,11
Annual energy consumption <sup>3)</sup>		kWh/a	327	455	—	—
Heating capacity	Nominal (Min - Max)	kW	8,0 [2,0 - 9,0]	11,2 [3,1 - 14,0]	14,0 [3,2 - 16,0]	16,0 [3,3 - 18,0]
COP <sup>1)</sup>		W/W	4,30	5,00	4,61	4,30
SCOP <sup>2)</sup>			<b>4,8 A++</b>	<b>4,9 A++</b>	<b>4,7</b>	<b>4,6</b>
Pdesign at -10 °C		kW	5,2	8,0	9,5	10,6
Input power heating		kW	1,86	2,24	3,04	3,72
Annual energy consumption <sup>3)</sup>		kWh/a	1517	2286	—	—
Indoor unit			S-71PU2E5B	S-100PU2E5B	S-125PU2E5B	S-140PU2E5B
Air volume	Hi / Med / Lo	m <sup>3</sup> /min	22,0 / 16,0 / 13,0	36,0 / 26,0 / 18,0	37,0 / 27,0 / 19,0	38,0 / 29,0 / 20,0
Sound pressure <sup>4)</sup>	Hi / Med / Lo	dB(A)	37 / 31 / 28	45 / 38 / 32	46 / 39 / 33	47 / 40 / 34
Dimension	Indoor (H x W x D)	mm	256 x 840 x 840	319 x 840 x 840	319 x 840 x 840	319 x 840 x 840
	Panel (H x W x D)	mm	33,5 x 950 x 950	33,5 x 950 x 950	33,5 x 950 x 950	33,5 x 950 x 950
Net weight	Indoor / Panel	kg	20 / 5	25 / 5	25 / 5	25 / 5
Outdoor unit			U-71PZH2E8	U-100PZH2E8	U-125PZH2E8	U-140PZH2E8
Power source		V	380 - 400 - 415	380 - 400 - 415	380 - 400 - 415	380 - 400 - 415
Current	Cool	A	2,75 - 2,65 - 2,55	3,50 - 3,35 - 3,20	5,15 - 4,90 - 4,70	6,45 - 6,15 - 5,90
	Heat	A	2,90 - 2,80 - 2,70	3,45 - 3,30 - 3,15	4,75 - 4,50 - 4,35	5,85 - 5,55 - 5,35
Air volume	Cool / Heat	m <sup>3</sup> /min	61 / 60	118 / 108	125 / 112	129 / 116
Sound pressure	Cool / Heat (Hi)	dB(A)	48 / 50	52 / 52	53 / 53	54 / 54
Sound power	Cool / Heat (Hi)	dB(A)	65 / 67	69 / 69	70 / 70	71 / 71
Dimension	H x W x D	mm	996 x 940 x 340	1416 x 940 x 340	1416 x 940 x 340	1416 x 940 x 340
Net weight		kg	68	99	99	99
Piping connections	Liquid pipe	Inch (mm)	3/8 (9,52)	3/8 (9,52)	3/8 (9,52)	3/8 (9,52)
	Gas pipe	Inch (mm)	5/8 (15,88)	5/8 (15,88)	5/8 (15,88)	5/8 (15,88)
Pipe length range		m	5 - 50	5 - 85	5 - 85	5 - 85
Elevation difference (in/out) <sup>5)</sup>		m	30	30	30	30
Pipe length for additional gas		m	30	30	30	30
Additional gas amount		g/m	45	45	45	45
Refrigerant (R32) / CO <sub>2</sub> Eq.		kg / T	1,95 / 1,316	3,05 / 2,059	3,05 / 2,059	3,05 / 2,059
Operating range	Cool Min ~ Max	°C	-15 ~ +46	-20 <sup>6)</sup> ~ +46	-20 <sup>6)</sup> ~ +46	-20 <sup>6)</sup> ~ +46
	Heat Min ~ Max	°C	-20 ~ +24	-20 ~ +24	-20 ~ +24	-20 ~ +24

1) EER and COP calculation is based in accordance to EN14511. 2) Energy Label Scale from A+++ to D. For models below 12 kW, the SEER and SCOP is calculated based on values of EU/626/2011. For models above 12 kW, the SEER and SCOP is calculated based on values of EU/2281/2016. 3) The annual energy consumption is calculated in accordance to EU/626/2011. 4) The sound pressure of the units shows the value measured of the position 1,5 m below the unit. The sound pressure is measured in accordance with Eurovent 6/C/006-97 specification. 5) When installing the outdoor unit at a higher position than the indoor unit. 6) For models 100 - 140PZH2E5(8), it is possible to operate the lowest -20 °C in the computer rooms with the piping length of 30 m or less. \* Recommended fuse for the indoor 3 A.



SEER and SCOP: For KIT-36PU2ZH5. ECONAVI and INTERNET CONTROL: Optional.  
Compatible with all Panasonic connectivity solutions. For detailed information go to the Control Systems section.



CZ-RTC5B

CZ-KPU3W  
Standard panel.CZ-KPU3AW  
Optional Econavi  
panel (CZ-RTC5B is  
required).

  
CZ-CNEXU1  
Optional  
nanoe X Generator  
Mark 1 kit (CZ-RTC5B  
is required).

## PACi Standard 4 Way 90x90 Cassette Inverter+ • R32 refrigerant

			Single Phase					
			6,0 kW	7,1 kW	10,0 kW	12,5 kW	14,0 kW	
KIT			KIT-60PU2Z5	KIT-71PU2Z5	KIT-100PU2Z5	KIT-125PU2Z5	KIT-140PU2Z5	
Remote controller			CZ-RTC5B	CZ-RTC5B	CZ-RTC5B	CZ-RTC5B	CZ-RTC5B	
Cooling capacity	Nominal (Min - Max)	kW	6,0(2,0 - 7,1)	7,1(2,0 - 7,7)	10,0(3,0 - 11,5)	12,5(3,2 - 13,5)	14,0(3,3 - 15,0)	
EER <sup>1)</sup>	Nominal (Min - Max)	W/W	4,00	3,50	3,82(5,36 - 2,88)	3,58(5,33 - 2,81)	3,23(5,32 - 2,73)	
<b>SEER <sup>2)</sup></b>			<b>7,6 A++</b>	<b>7,6 A++</b>	<b>6,8 A++</b>	<b>6,8</b>	<b>6,5</b>	
P <sub>design</sub>		kW	6,0	7,1	10,0	12,5	14,0	
Input power cooling	Nominal (Min - Max)	kW	1,50	2,03	2,62(0,56 - 4,00)	3,49(0,60 - 4,80)	4,34(0,62 - 5,50)	
Annual energy consumption <sup>3)</sup>		kWh/a	276	327	515	—	—	
Heating capacity	Nominal (Min - Max)	kW	6,0(1,8 - 7,0)	7,1(1,8 - 8,1)	10,0(3,0 - 14,0)	12,5(3,3 - 15,0)	14,0(3,4 - 16,0)	
COP <sup>1)</sup>	Nominal (Min - Max)	W/W	4,72	4,36	4,93(3,59 - 5,36)	4,43(3,57 - 5,50)	4,18(3,33 - 5,48)	
<b>SCOP <sup>2)</sup></b>			<b>4,7 A++</b>	<b>4,7 A++</b>	<b>4,4 A+</b>	<b>4,0</b>	<b>3,9</b>	
P <sub>design</sub> at -10 °C		kW	6,0	6,0	10,0	12,5	14,0	
Input power heating	Nominal (Min - Max)	kW	1,27	1,63	2,03(0,56 - 3,90)	2,82(0,60 - 4,20)	3,35(0,62 - 4,80)	
Annual energy consumption <sup>3)</sup>		kWh/a	1787	1787	3182	—	—	
Indoor unit			S-60PU2E5B	S-71PU2E5B	S-100PU2E5B	S-125PU2E5B	S-140PU2E5B	
Air volume	Hi / Med / Lo	m <sup>3</sup> /min	21,0/16,0/13,0	22,0/16,0/13,0	36,0/26,0/18,0	37,0/27,0/19,0	38,0/29,0/20,0	
Moisture removal volume		L/h	1,7	2,5	2,7	4,8	6,0	
Sound pressure <sup>4)</sup>	Hi / Med / Lo	dB(A)	36/31/28	37/31/28	45/38/32	46/39/33	47/40/34	
Sound power	Hi / Med / Lo	dB(A)	51/46/43	52/46/43	60/53/47	61/54/48	62/55/49	
Dimension	Indoor (H x W x D)	mm	256 x 840 x 840	256 x 840 x 840	319 x 840 x 840	319 x 840 x 840	319 x 840 x 840	
	Panel (H x W x D)	mm	33,5 x 950 x 950	33,5 x 950 x 950	33,5 x 950 x 950	33,5 x 950 x 950	33,5 x 950 x 950	
Net weight	Indoor / Panel	kg	20/5	20/5	25/5	25/5	25/5	
Outdoor unit			U-60PZ2E5	U-71PZ2E5	U-100PZ2E5	U-125PZ2E5	U-140PZ2E5	
Power source		V	220 - 230 - 240	220 - 230 - 240	220 - 230 - 240	220 - 230 - 240	220 - 230 - 240	
Current	Cool	A	7,40 - 7,05 - 6,75	9,95 - 9,50 - 9,10	12,10 - 11,50 - 11,10	16,30 - 15,60 - 15,00	20,40 - 19,50 - 18,70	
	Heat	A	6,25 - 5,95 - 5,70	8,05 - 7,70 - 7,35	9,25 - 8,85 - 8,50	13,10 - 12,60 - 12,00	15,60 - 15,00 - 14,30	
Air volume	Cool / Heat	m <sup>3</sup> /min	40/45	50/45	76/70	86/78	89/83	
Sound pressure	Cool / Heat (Hi)	dB(A)	46/48	49/49	52/52	55/55	56/56	
Sound power	Cool / Heat (Hi)	dB(A)	65/68	69/69	70/70	73/73	74/74	
Dimension	H x W x D	mm	695 x 875 x 320	695 x 875 x 320	996 x 980 x 370	996 x 980 x 370	996 x 980 x 370	
Net weight		kg	44	44	90	94	94	
Piping connections	Liquid pipe	Inch (mm)	3/8(9,52)	3/8(9,52)	3/8(9,52)	3/8(9,52)	3/8(9,52)	
	Gas pipe	Inch (mm)	5/8(15,88)	5/8(15,88)	5/8(15,88)	5/8(15,88)	5/8(15,88)	
Pipe length range		m	3 - 40	3 - 40	5 - 50	5 - 50	5 - 50	
Elevation difference (in/out) <sup>5)</sup>		m	30	30	30	30	30	
Pipe length for additional gas		m	30	30	30	30	30	
Additional gas amount		g/m	35	35	45	45	45	
Refrigerant (R32) / CO <sub>2</sub> Eq.		kg / T	1,45/0,979	1,45/0,979	2,60/1,755	2,98/2,0115	2,98/2,0115	
Operating range	Cool Min - Max	°C	-10 ~ +43	-10 ~ +43	-10 ~ +43	-10 ~ +43	-10 ~ +43	
	Heat Min - Max	°C	-15 ~ +24	-15 ~ +24	-15 ~ +24	-15 ~ +24	-15 ~ +24	

### Accessories

<b>CZ-RTC6</b>	<b>NEW</b> Wired remote controller (non-wireless)
<b>CZ-RTC6BL</b>	<b>NEW</b> Wired remote controller with Bluetooth®
<b>CZ-RTC5B</b>	Wired remote controller with Econavi function and datanavi
<b>CZ-RWS3 + CZ-RWRU3W</b>	Infrared remote controller
<b>CZ-CAPWFC1</b>	Commercial Wi-Fi Adaptor
<b>CZ-KPU3AW</b>	Econavi exclusive panel

### Accessories

<b>CZ-CNEXU1</b>	nanoe X Generator Mark 1 kit
<b>PAW-WTRAY</b>	Tray for condenser water compatible with outdoor elevation platform
<b>PAW-GRDBSE20</b>	Outdoor base ground support for noise and vibration absorption
<b>PAW-GRDSTD40</b>	Outdoor elevation platform 400 x 900 x 400 mm
<b>CZ-CENSC1</b>	Econavi energy savings sensor



**CZ-RTC6**  
**CZ-RTC6BL**  
Optional Controller.  
Wired remote controller.



**CZ-RWS3 +**  
**CZ-RWRU3W**  
Optional Controller.  
Infrared remote controller.



## PACi Standard 4 Way 90x90 Cassette Inverter+ • R32 refrigerant

			Three Phase		
			10,0 kW	12,5 kW	14,0 kW
KIT			KIT-100PU2Z8	KIT-125PU2Z8	KIT-140PU2Z8
Remote controller			CZ-RTC5B	CZ-RTC5B	CZ-RTC5B
Cooling capacity	Nominal (Min - Max)	kW	10,0(3,0 - 11,5)	12,5(3,2 - 13,5)	14,0(3,3 - 15,0)
EER <sup>1)</sup>	Nominal (Min - Max)	W/W	3,82(5,36 - 2,88)	3,58(5,33 - 2,81)	3,23(5,32 - 2,73)
<b>SEER <sup>2)</sup></b>			<b>6,7 A++</b>	<b>6,7</b>	<b>6,5</b>
Pdesign		kW	10,0	12,5	14,0
Input power cooling	Nominal (Min - Max)	kW	2,62(0,56 - 4,00)	3,49(0,60 - 4,80)	4,34(0,62 - 5,50)
Annual energy consumption <sup>3)</sup>		kWh/a	521	—	—
Heating capacity	Nominal (Min - Max)	kW	10,0(3,0 - 14,0)	12,5(3,3 - 15,0)	14,0(3,4 - 16,0)
COP <sup>1)</sup>	Nominal (Min - Max)	W/W	4,93(3,59 - 5,36)	4,43(3,57 - 5,50)	4,18(3,33 - 5,48)
<b>SCOP <sup>2)</sup></b>			<b>4,4 A+</b>	<b>4,0</b>	<b>3,9</b>
Pdesign at -10 °C		kW	10,0	12,5	14,0
Input power heating	Nominal (Min - Max)	kW	2,03(0,56 - 3,90)	2,82(0,60 - 4,20)	3,35(0,62 - 4,80)
Annual energy consumption <sup>3)</sup>		kWh/a	3182	—	—
Indoor unit			S-100PU2E5B	S-125PU2E5B	S-140PU2E5B
Air volume	Hi / Med / Lo	m <sup>3</sup> /min	36,0/26,0/18,0	37,0/27,0/19,0	38,0/29,0/20,0
Moisture removal volume		L/h	2,7	4,8	6,0
Sound pressure <sup>4)</sup>	Hi / Med / Lo	dB(A)	45/38/32	46/39/33	47/40/34
Sound power	Hi / Med / Lo	dB(A)	60/53/47	61/54/48	62/55/49
Dimension	Indoor (H x W x D)	mm	319 x 840 x 840	319 x 840 x 840	319 x 840 x 840
	Panel (H x W x D)	mm	33,5 x 950 x 950	33,5 x 950 x 950	33,5 x 950 x 950
Net weight	Indoor / Panel	kg	25/5	25/5	25/5
Outdoor unit			U-100PZ2E8	U-125PZ2E8	U-140PZ2E8
Power source		V	380 - 400 - 415	380 - 400 - 415	380 - 400 - 415
Current	Cool	A	4,10 - 3,90 - 3,75	5,45 - 5,20 - 5,00	6,85 - 6,50 - 6,25
	Heat	A	3,15 - 3,00 - 2,90	4,40 - 4,15 - 4,00	5,25 - 4,95 - 4,80
Air volume	Cool / Heat	m <sup>3</sup> /min	76/70	86/78	89/83
Sound pressure	Cool / Heat (Hi)	dB(A)	52/52	55/55	56/56
Sound power	Cool / Heat (Hi)	dB(A)	70/70	73/73	74/74
Dimension	H x W x D	mm	996 x 980 x 370	996 x 980 x 370	996 x 980 x 370
Net weight		kg	90	94	94
Piping connections	Liquid pipe	Inch (mm)	3/8(9,52)	3/8(9,52)	3/8(9,52)
	Gas pipe	Inch (mm)	5/8(15,88)	5/8(15,88)	5/8(15,88)
Pipe length range		m	5 - 50	5 - 50	5 - 50
Elevation difference (in/out) <sup>5)</sup>		m	30	30	30
Pipe length for additional gas		m	30	30	30
Additional gas amount		g/m	45	45	45
Refrigerant (R32) / CO <sub>2</sub> Eq.		kg / T	2,60/1,755	2,98/2,0115	2,98/2,0115
Operating range	Cool Min ~ Max	°C	-10 ~ +43	-10 ~ +43	-10 ~ +43
	Heat Min ~ Max	°C	-15 ~ +24	-15 ~ +24	-15 ~ +24

1) EER and COP calculation is based in accordance to EN14511. 2) Energy Label Scale from A+++ to D. For models below 12 kW, the SEER and SCOP is calculated based on values of EU/626/2011. For models above 12 kW, the SEER and SCOP is calculated based on values of EU/2281/2016. 3) The annual energy consumption is calculated in accordance to EU/626/2011. 4) The sound pressure of the units shows the value measured of the position 1,5 m below the unit. The sound pressure is measured in accordance with Eurovent 6/C/006-97 specification. 5) When installing the outdoor unit at a higher position than the indoor unit. \* Recommended fuse for the indoor 3 A.



SEER and SCOP: For KIT-60PU2Z5 and KIT-71PU2Z5. ECONAVI and INTERNET CONTROL: Optional.  
Compatible with all Panasonic connectivity solutions. For detailed information go to the Control Systems section.



CZ-RTC5B

## PACi Elite Ceiling Inverter+ • R32 refrigerant

			Single Phase							
			3,6 kW	5,0 kW	6,0 kW	7,1 kW	10,0 kW	12,5 kW	14,0 kW	
KIT			KIT-36PT2ZH5	KIT-50PT2ZH5	KIT-60PT2ZH5	KIT-71PT2ZH5	KIT-100PT2ZH5	KIT-125PT2ZH5	KIT-140PT2ZH5	
Remote controller			CZ-RTC5B	CZ-RTC5B	CZ-RTC5B	CZ-RTC5B	CZ-RTC5B	CZ-RTC5B	CZ-RTC5B	
Cooling capacity	Nominal (Min - Max)	kW	3,6(1,5 - 4,0)	5,0(1,5 - 5,6)	6,0(2,0 - 7,1)	7,1(2,2 - 9,0)	10,0(3,1 - 12,5)	12,5(3,2 - 14,0)	14,0(3,3 - 16,0)	
EER <sup>1)</sup>		W/W	5,07	4,17	4,08	3,78	4,05	3,45	3,10	
SEER <sup>2)</sup>			<b>7,2A++</b>	<b>7,0A++</b>	<b>7,2A++</b>	<b>6,7A++</b>	<b>7,0A++</b>	<b>6,6</b>	<b>6,2</b>	
Pdesign		kW	3,6	5,0	6,0	7,1	10,0	12,5	14,0	
Input power cooling		kW	0,71	1,20	1,47	1,88	2,47	3,62	4,52	
Annual energy consumption <sup>3)</sup>		kWh/a	175	250	292	371	500	—	—	
Heating capacity	Nominal (Min - Max)	kW	4,0(1,5 - 5,0)	5,6(1,5 - 6,5)	7,0(1,8 - 8,0)	8,0(2,0 - 9,0)	11,2(3,1 - 14,0)	14,0(3,2 - 16,0)	16,0(3,3 - 18,0)	
COP <sup>1)</sup>		W/W	5,19	4,34	4,43	4,15	4,31	3,99	3,67	
SCOP <sup>2)</sup>			<b>4,8A++</b>	<b>4,6A++</b>	<b>4,7A++</b>	<b>4,6A++</b>	<b>4,6A++</b>	<b>4,4</b>	<b>4,3</b>	
Pdesign	at -10 °C	kW	3,6	4,5	6,0	5,2	8,0	9,5	10,6	
Input power heating		kW	0,77	1,29	1,58	1,93	2,60	3,51	4,36	
Annual energy consumption <sup>3)</sup>		kWh/a	1050	1370	1787	1583	2435	—	—	
Indoor unit			S-36PT2E5B	S-50PT2E5B	S-60PT2E5B	S-71PT2E5B	S-100PT2E5B	S-125PT2E5B	S-140PT2E5B	
Air volume	Hi / Med / Lo	m <sup>3</sup> /min	14,0/12,0/10,5	15,0/12,5/10,5	20,0/17,0/14,5	21,0/18,0/15,5	30,0/25,0/23,0	34,0/28,0/24,0	35,0/29,0/25,0	
Sound pressure <sup>4)</sup>	Hi / Med / Lo	dB(A)	36/32/29	37/33/29	38/34/30	39/35/31	42/37/35	46/40/36	47/41/37	
Dimension	HxWxD	mm	235x960x690	235x960x690	235x1275x690	235x1275x690	235x1590x690	235x1590x690	235x1590x690	
Net weight		kg	27	27	33	33	40	40	40	
Outdoor unit			U-36PZH2E5	U-50PZH2E5	U-60PZH2E5	U-71PZH2E5	U-100PZH2E5	U-125PZH2E5	U-140PZH2E5	
Power source		V	220 - 230 - 240	220 - 230 - 240	220 - 230 - 240	220 - 230 - 240	220 - 230 - 240	220 - 230 - 240	220 - 230 - 240	
Current	Cool	A	3,35 - 3,25 - 3,10	5,60 - 5,35 - 5,10	7,15 - 6,85 - 6,55	8,80 - 8,45 - 8,10	11,40 - 10,90 - 10,50	16,80 - 16,00 - 15,40	21,00 - 20,10 - 19,30	
	Heat	A	3,65 - 3,50 - 3,35	6,10 - 5,85 - 5,60	7,75 - 7,40 - 7,10	8,90 - 8,50 - 8,20	12,00 - 11,50 - 11,00	16,20 - 15,50 - 14,90	20,30 - 19,40 - 18,60	
Air volume	Cool / Heat	m <sup>3</sup> /min	40/40	40/45	40/45	61/60	118/108	125/122	129/116	
Sound pressure	Cool / Heat (Hi)	dB(A)	43/44	45/48	46/49	48/50	52/52	53/53	54/54	
Sound power	Cool / Heat (Hi)	dB(A)	62/64	64/68	65/69	65/67	69/69	70/70	71/71	
Dimension	HxWxD	mm	695x875x320	695x875x320	695x875x320	996x940x340	1416x940x340	1416x940x340	1416x940x340	
Net weight		kg	43	43	44	68	99	99	99	
Piping connections	Liquid pipe	Inch (mm)	1/4(6,35)	1/4(6,35)	3/8(9,52)	3/8(9,52)	3/8(9,52)	3/8(9,52)	3/8(9,52)	
	Gas pipe	Inch (mm)	1/2(12,70)	1/2(12,70)	5/8(15,88)	5/8(15,88)	5/8(15,88)	5/8(15,88)	5/8(15,88)	
Pipe length range		m	3 - 40	3 - 40	3 - 40	5 - 50	5 - 85	5 - 85	5 - 85	
Elevation difference (in/out) <sup>5)</sup>		m	30	30	30	30	30	30	30	
Pipe length for additional gas		m	30	30	30	30	30	30	30	
Additional gas amount		g/m	20	20	35	45	45	45	45	
Refrigerant (R32) / CO <sub>2</sub> Eq.		kg / T	1,15/0,776	1,15/0,776	1,45/0,979	1,95/1,316	3,05/2,059	3,05/2,059	3,05/2,059	
Operating range	Cool Min ~ Max	°C	-15 ~ +46	-15 ~ +46	-15 ~ +46	-15 ~ +46	-20 <sup>6)</sup> ~ +46	-20 <sup>6)</sup> ~ +46	-20 <sup>6)</sup> ~ +46	
	Heat Min ~ Max	°C	-20 ~ +24	-20 ~ +24	-20 ~ +24	-20 ~ +24	-20 ~ +24	-20 ~ +24	-20 ~ +24	

### Accessories

<b>CZ-RTC6</b>	<b>NEW</b> Wired remote controller (non-wireless)
<b>CZ-RTC6BL</b>	<b>NEW</b> Wired remote controller with Bluetooth®
<b>CZ-RTC5B</b>	Wired remote controller with Econavi function and datanavi
<b>CZ-RWS3 + CZ-RWRT3</b>	Infrared remote controller
<b>CZ-CAPWFC1</b>	Commercial Wi-Fi Adaptor

### Accessories

<b>PAW-WTRAY</b>	Tray for condenser water compatible with outdoor elevation platform
<b>PAW-GRDBSE20</b>	Outdoor base ground support for noise and vibration absorption
<b>PAW-GRDSTD40</b>	Outdoor elevation platform 400x900x400 mm
<b>CZ-CENSC1</b>	Econavi energy savings sensor



**CZ-RTC6**  
**CZ-RTC6BL**  
Optional Controller.  
Wired remote controller.



**CZ-RWS3 +**  
**CZ-RWRT3**  
Optional Controller.  
Infrared remote controller.



**CZ-CENSC1**  
Optional Econavi  
Sensor.



## PACi Elite Ceiling Inverter+ • R32 refrigerant

### Three Phase

			7,1 kW	10,0 kW	12,5 kW	14,0 kW
KIT			KIT-71PT2ZH8	KIT-100PT2ZH8	KIT-125PT2ZH8	KIT-140PT2ZH8
Remote controller			CZ-RTC5B	CZ-RTC5B	CZ-RTC5B	CZ-RTC5B
Cooling capacity	Nominal (Min - Max)	kW	7,1 [2,2 - 9,0]	10,0 [3,1 - 12,5]	12,5 [3,2 - 14,0]	14,0 [3,3 - 16,0]
EER <sup>1)</sup>		W/W	3,78	4,05	3,45	3,10
<b>SEER <sup>2)</sup></b>			<b>6,6 A++</b>	<b>6,9 A++</b>	<b>6,6</b>	<b>6,2</b>
Pdesign		kW	7,1	10,0	12,5	14,0
Input power cooling		kW	1,88	2,47	3,62	4,52
Annual energy consumption <sup>3)</sup>		kWh/a	375	507	—	—
Heating capacity	Nominal (Min - Max)	kW	8,0 [2,0 - 9,0]	11,2 [3,1 - 14,0]	14,0 [3,2 - 16,0]	16,0 [3,3 - 18,0]
COP <sup>1)</sup>		W/W	4,15	4,31	3,99	3,67
<b>SCOP <sup>2)</sup></b>			<b>4,6 A++</b>	<b>4,6 A++</b>	<b>4,4</b>	<b>4,3</b>
Pdesign at -10 °C		kW	5,2	8,0	9,5	10,6
Input power heating		kW	1,93	2,60	3,51	4,36
Annual energy consumption <sup>3)</sup>		kWh/a	1583	2435	—	—
Indoor unit			S-71PT2E5B	S-100PT2E5B	S-125PT2E5B	S-140PT2E5B
Air volume	Hi / Med / Lo	m <sup>3</sup> /min	21,0/18,0/15,5	30,0/25,0/23,0	34,0/28,0/24,0	35,0/29,0/25,0
Sound pressure <sup>4)</sup>	Hi / Med / Lo	dB(A)	39/35/31	42/37/35	46/40/36	47/41/37
Dimension	HxWxD	mm	235 x 1275 x 690	235 x 1590 x 690	235 x 1590 x 690	235 x 1590 x 690
Net weight		kg	33	40	40	40
Outdoor unit			U-71PZH2E8	U-100PZH2E8	U-125PZH2E8	U-140PZH2E8
Power source		V	380-400-415	380-400-415	380-400-415	380-400-415
Current	Cool	A	2,95-2,85-2,75	3,85-3,65-3,55	5,65-5,40-5,20	7,10-6,75-6,50
	Heat	A	3,00-2,90-2,80	4,05-3,85-3,75	5,50-5,20-5,05	6,85-6,50-6,30
Air volume	Cool / Heat	m <sup>3</sup> /min	61/60	118/108	125/112	129/116
Sound pressure	Cool / Heat (Hi)	dB(A)	48/50	52/52	53/53	54/54
Sound power	Cool / Heat (Hi)	dB(A)	65/67	69/69	70/70	71/71
Dimension	HxWxD	mm	996 x 940 x 340	1416 x 940 x 340	1416 x 940 x 340	1416 x 940 x 340
Net weight		kg	68	99	99	99
Piping connections	Liquid pipe	Inch (mm)	3/8 (9,52)	3/8 (9,52)	3/8 (9,52)	3/8 (9,52)
	Gas pipe	Inch (mm)	5/8 (15,88)	5/8 (15,88)	5/8 (15,88)	5/8 (15,88)
Pipe length range		m	5-50	5-85	5-85	5-85
Elevation difference (in/out) <sup>5)</sup>		m	30	30	30	30
Pipe length for additional gas		m	30	30	30	30
Additional gas amount		g/m	45	45	45	45
Refrigerant (R32) / CO <sub>2</sub> Eq.		kg / T	1,95/1,316	3,05/2,059	3,05/2,059	3,05/2,059
Operating range	Cool Min ~ Max	°C	-15 ~ +46	-20 <sup>6)</sup> ~ +46	-20 <sup>6)</sup> ~ +46	-20 <sup>6)</sup> ~ +46
	Heat Min ~ Max	°C	-20 ~ +24	-20 ~ +24	-20 ~ +24	-20 ~ +24

1) EER and COP calculation is based in accordance to EN14511. 2) Energy Label Scale from A+++ to D. For models below 12 kW, the SEER and SCOP is calculated based on values of EU/626/2011. For models above 12 kW, the SEER and SCOP is calculated based on values of EU/2281/2016. 3) The annual energy consumption is calculated in accordance to EU/626/2011. 4) The sound pressure of the units shows the value measured of the position 1 m in front of the main body and 1 m below the unit. The sound pressure is measured in accordance with Eurovent 6/C/006-97 specification. 5) When installing the outdoor unit at a higher position than the indoor unit. 6) For models 100 ~ 140PZH2E5(8), it is possible to operate the lowest -20 °C in the computer rooms with the piping length of 30 m or less. \* Recommended fuse for the indoor 3 A.



SEER and SCOP: For KIT-36PT2ZH5. INTERNET CONTROL: Optional.

Compatible with all Panasonic connectivity solutions. For detailed information go to the Control Systems section.



CZ-RTC5B

## PACi Standard Ceiling Inverter+ • R32 refrigerant

			Single Phase					
			6,0 kW	7,1 kW	10,0 kW	12,5 kW	14,0 kW	
KIT			KIT-60PT2Z5	KIT-71PT2Z5	KIT-100PT2Z5	KIT-125PT2Z5	KIT-140PT2Z5	
Remote controller			CZ-RTC5B					
Cooling capacity	Nominal (Min - Max)	kW	6,0(2,0 - 7,1)	7,1(2,0 - 7,7)	10,0(3,0 - 11,5)	12,5(3,2 - 13,5)	14,0(3,3 - 15,0)	
EER <sup>1)</sup>	Nominal (Min - Max)	W/W	4,00	3,55	3,64(5,36 - 2,80)	3,32(5,33 - 2,77)	2,98(5,32 - 2,73)	
<b>SEER <sup>2)</sup></b>			<b>6,8 A++</b>	<b>6,5 A++</b>	<b>6,5 A++</b>	<b>5,8</b>	<b>5,5</b>	
P <sub>design</sub>		kW	6,0	7,1	10,0	12,5	14,0	
Input power cooling	Nominal (Min - Max)	kW	1,50	2,00	2,75(0,56 - 4,10)	3,76(0,60 - 4,88)	4,70(0,62 - 5,50)	
Annual energy consumption <sup>3)</sup>		kWh/a	309	382	535	1300	1530	
Heating capacity	Nominal (Min - Max)	kW	6,0(1,8 - 7,0)	7,1(1,8 - 8,1)	10,0(3,0 - 14,0)	12,5(3,3 - 15,0)	14,0(3,4 - 16,0)	
COP <sup>1)</sup>	Nominal (Min - Max)	W/W	4,80	4,41	4,24(5,36 - 3,50)	3,89(4,52 - 3,41)	3,70(5,48 - 3,08)	
<b>SCOP <sup>2)</sup></b>			<b>4,6 A++</b>	<b>4,3 A+</b>	<b>4,2 A+</b>	<b>3,8</b>	<b>3,7</b>	
P <sub>design</sub> at -10 °C		kW	6,0	6,0	10,0	12,5	13,6	
Input power heating	Nominal (Min - Max)	kW	1,25	1,62	2,36(0,56 - 4,00)	3,21(0,73 - 4,40)	3,78(0,62 - 5,20)	
Annual energy consumption <sup>3)</sup>		kWh/a	1826	1953	3324	4669	5153	
Indoor unit			S-60PT2E5B	S-71PT2E5B	S-100PT2E5B	S-125PT2E5B	S-140PT2E5B	
Air volume	Hi / Med / Lo	m <sup>3</sup> /min	20,0/17,0/14,5	21,0/18,0/15,5	30/25/23	34/28/24	35/29/25	
Moisture removal volume		L/h	3,4	4,2	6,0	7,9	9,0	
Sound pressure <sup>4)</sup>	Hi / Med / Lo	dB(A)	38/34/30	39/35/31	42/37/35	46/40/36	47/41/37	
Sound power	Hi / Med / Lo	dB(A)	56/52/48	57/53/49	60/55/53	64/58/54	65/59/55	
Dimension	H x W x D	mm	235 x 1275 x 690	235 x 1275 x 690	235 x 1590 x 690	235 x 1590 x 690	235 x 1590 x 690	
Net weight		kg	33	33	40	40	40	
Outdoor unit			U-60PZ2E5	U-71PZ2E5	U-100PZ2E5	U-125PZ2E5	U-140PZ2E5	
Power source		V	220 - 230 - 240	220 - 230 - 240	220 - 230 - 240	220 - 230 - 240	220 - 230 - 240	
Current	Cool	A	7,30 - 7,00 - 6,70	9,70 - 9,30 - 8,90	12,80 - 12,20 - 11,70	17,60 - 16,90 - 16,20	22,10 - 21,20 - 20,30	
	Heat	A	6,05 - 5,80 - 5,55	7,85 - 7,50 - 7,20	10,90 - 10,40 - 10,00	15,00 - 14,30 - 13,70	17,70 - 16,90 - 16,20	
Air volume	Cool / Heat	m <sup>3</sup> /min	40/45	50/45	76/70	86/78	89/83	
Sound pressure	Cool / Heat (Hi)	dB(A)	46/48	49/49	52/52	55/55	56/56	
Sound power	Cool / Heat (Hi)	dB(A)	65/68	69/69	70/70	73/73	74/74	
Dimension	H x W x D	mm	695 x 875 x 320	695 x 875 x 320	996 x 980 x 370	996 x 980 x 370	996 x 980 x 370	
Net weight		kg	44	44	90	94	94	
Piping connections	Liquid pipe	Inch (mm)	3/8(9,52)	3/8(9,52)	3/8(9,52)	3/8(9,52)	3/8(9,52)	
	Gas pipe	Inch (mm)	5/8(15,88)	5/8(15,88)	5/8(15,88)	5/8(15,88)	5/8(15,88)	
Pipe length range		m	3 - 40	3 - 40	5 - 50	5 - 50	5 - 50	
Elevation difference (in/out) <sup>5)</sup>		m	30	30	30	30	30	
Pipe length for additional gas		m	30	30	30	30	30	
Additional gas amount		g/m	35	35	45	45	45	
Refrigerant (R32) / CO <sub>2</sub> Eq.		kg / T	1,45/0,979	1,45/0,979	2,60/1,755	2,98/2,0115	2,98/2,0115	
Operating range	Cool Min ~ Max	°C	-10 ~ +43	-10 ~ +43	-10 ~ +43	-10 ~ +43	-10 ~ +43	
	Heat Min ~ Max	°C	-15 ~ +24	-15 ~ +24	-15 ~ +24	-15 ~ +24	-15 ~ +24	

### Accessories

<b>CZ-RTC6</b>	<b>NEW</b> Wired remote controller (non-wireless)
<b>CZ-RTC6BL</b>	<b>NEW</b> Wired remote controller with Bluetooth®
<b>CZ-RTC5B</b>	Wired remote controller with Econavi function and datanavi
<b>CZ-RWS3 + CZ-RWRT3</b>	Infrared remote controller
<b>CZ-CAPWFC1</b>	Commercial Wi-Fi Adaptor

### Accessories

<b>PAW-WTRAY</b>	Tray for condenser water compatible with outdoor elevation platform
<b>PAW-GRDBSE20</b>	Outdoor base ground support for noise and vibration absorption
<b>PAW-GRDSTD40</b>	Outdoor elevation platform 400 x 900 x 400 mm
<b>CZ-CENSC1</b>	Econavi energy savings sensor





**CZ-RTC6**  
**CZ-RTC6BL**  
Optional Controller.  
Wired remote controller.

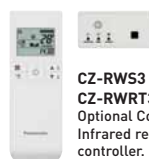

**CZ-RWS3 +**  
**CZ-RWRT3**  
Optional Controller.  
Infrared remote controller.



**CZ-CENS1**  
Optional Econavi  
Sensor.



## PACi Standard Ceiling Inverter+ • R32 refrigerant

			Three Phase		
			10,0 kW	12,5 kW	14,0 kW
KIT			KIT-100PT2Z8	KIT-125PT2Z8	KIT-140PT2Z8
Remote controller			CZ-RTC5B	CZ-RTC5B	CZ-RTC5B
Cooling capacity	Nominal (Min - Max)	kW	10,0(3,0 - 11,5)	12,5(3,2 - 13,5)	14,0(3,3 - 15,0)
EER <sup>1)</sup>	Nominal (Min - Max)	W/W	3,64(5,36 - 2,80)	3,32(5,33 - 2,77)	2,98(5,32 - 2,73)
<b>SEER <sup>2)</sup></b>			<b>6,5A++</b>	<b>5,8</b>	<b>5,5</b>
Pdesign		kW	10,0	12,5	14,0
Input power cooling	Nominal (Min - Max)	kW	2,75(0,56 - 4,10)	3,76(0,60 - 4,88)	4,70(0,62 - 5,50)
Annual energy consumption <sup>3)</sup>		kWh/a	538	1304	1534
Heating capacity	Nominal (Min - Max)	kW	10,0(3,0 - 14,0)	12,5(3,3 - 15,0)	14,0(3,4 - 16,0)
COP <sup>1)</sup>	Nominal (Min - Max)	W/W	4,24(5,36 - 3,50)	3,89(4,52 - 3,41)	3,70(5,48 - 3,08)
<b>SCOP <sup>2)</sup></b>			<b>4,2A+</b>	<b>3,8</b>	<b>3,7</b>
Pdesign at -10 °C		kW	10,0	12,5	13,6
Input power heating	Nominal (Min - Max)	kW	2,36(0,56 - 4,00)	3,21(0,73 - 4,40)	3,78(0,62 - 5,20)
Annual energy consumption <sup>3)</sup>		kWh/a	3324	4669	5153
<b>Indoor unit</b>			<b>S-100PT2E5B</b>	<b>S-125PT2E5B</b>	<b>S-140PT2E5B</b>
Air volume	Hi / Med / Lo	m <sup>3</sup> /min	30/25/23	34/28/24	35/29/25
Moisture removal volume		L/h	6,0	7,9	9,0
Sound pressure <sup>4)</sup>	Hi / Med / Lo	dB(A)	42/37/35	46/40/36	47/41/37
Sound power	Hi / Med / Lo	dB(A)	60/55/53	64/58/54	65/59/55
Dimension	HxWxD	mm	235x1590x690	235x1590x690	235x1590x690
Net weight		kg	40	40	40
<b>Outdoor unit</b>			<b>U-100PZ2E8</b>	<b>U-125PZ2E8</b>	<b>U-140PZ2E8</b>
Power source		V	380 - 400 - 415	380 - 400 - 415	380 - 400 - 415
Current	Cool	A	4,37 - 4,15 - 4,00	5,90 - 5,60 - 5,40	7,40 - 7,05 - 6,80
	Heat	A	3,72 - 3,55 - 3,40	5,00 - 4,75 - 4,60	5,90 - 5,60 - 5,40
Air volume	Cool / Heat	m <sup>3</sup> /min	76/70	86/78	89/83
Sound pressure	Cool / Heat (Hi)	dB(A)	52/52	55/55	56/56
Sound power	Cool / Heat (Hi)	dB(A)	70/70	73/73	74/74
Dimension	HxWxD	mm	996x980x370	996x980x370	996x980x370
Net weight		kg	90	94	94
Piping connections	Liquid pipe	Inch (mm)	3/8(9,52)	3/8(9,52)	3/8(9,52)
	Gas pipe	Inch (mm)	5/8(15,88)	5/8(15,88)	5/8(15,88)
Pipe length range		m	5 - 50	5 - 50	5 - 50
Elevation difference (in/out) <sup>5)</sup>		m	30	30	30
Pipe length for additional gas		m	30	30	30
Additional gas amount		g/m	45	45	45
Refrigerant (R32) / CO <sub>2</sub> Eq.		kg / T	2,60/1,755	2,98/2,0115	2,98/2,0115
Operating range	Cool Min ~ Max	°C	-10 ~ +43	-10 ~ +43	-10 ~ +43
	Heat Min ~ Max	°C	-15 ~ +24	-15 ~ +24	-15 ~ +24

1) EER and COP calculation is based in accordance to EN14511. 2) Energy Label Scale from A+++ to D. For models below 12 kW, the SEER and SCOP is calculated based on values of EU/626/2011. For models above 12 kW, the SEER and SCOP is calculated based on values of EU/2281/2016. 3) The annual energy consumption is calculated in accordance to EU/626/2011. 4) The sound pressure of the units shows the value measured of the position 1 m in front of the main body and 1 m below the unit. The sound pressure is measured in accordance with Eurovent 6/C/006-97 specification. 5) When installing the outdoor unit at a higher position than the indoor unit. \* Recommended fuse for the indoor 3 A.



SEER and SCOP: For KIT-60PT2Z5. INTERNET CONTROL: Optional.  
Compatible with all Panasonic connectivity solutions. For detailed information go to the Control Systems section.

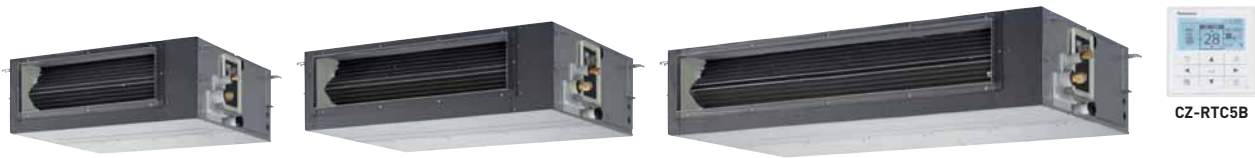

## PACi Elite High Static Pressure Hide Away Inverter+ • R32 refrigerant

			Single Phase							
			3,6 kW	5,0 kW	6,0 kW	7,1 kW	10,0 kW	12,5 kW	14,0 kW	
KIT			KIT-36PF1ZH5	KIT-50PF1ZH5	KIT-60PF1ZH5	KIT-71PF1ZH5	KIT-100PF1ZH5	KIT-125PF1ZH5	KIT-140PF1ZH5	
Remote controller			CZ-RTC5B	CZ-RTC5B	CZ-RTC5B	CZ-RTC5B	CZ-RTC5B	CZ-RTC5B	CZ-RTC5B	
Cooling capacity	Nominal (Min - Max)	kW	3,6(1,5 - 4,0)	5,0(1,5 - 5,6)	6,0(2,0 - 7,1)	7,1(2,2 - 9,0)	10,0(3,1 - 12,5)	12,5(3,2 - 14,0)	14,0(3,3 - 16,0)	
EER <sup>1)</sup>		W/W	4,74	4,03	3,68	3,84	4,13	3,52	3,26	
SEER <sup>2)</sup>			<b>6,1A++</b>	<b>5,9A+</b>	<b>6,4A++</b>	<b>6,5A++</b>	<b>6,2A++</b>	<b>5,9</b>	<b>5,7</b>	
Pdesign		kW	3,6	5,0	6,0	7,1	10,0	12,5	14,0	
Input power cooling		kW	0,76	1,24	1,63	1,85	2,42	3,55	4,30	
Annual energy consumption <sup>3)</sup>		kWh/a	207	297	328	382	564	—	—	
Heating capacity	Nominal (Min - Max)	kW	4,0(1,5 - 5,0)	5,6(1,5 - 6,5)	7,0(1,8 - 8,0)	8,0(2,0 - 9,0)	11,2(3,1 - 14,0)	14,0(3,2 - 16,0)	16,0(3,3 - 18,0)	
COP <sup>1)</sup>		W/W	4,76	4,18	4,14	4,00	4,31	4,02	3,65	
SCOP <sup>2)</sup>			<b>4,3A+</b>	<b>4,2A+</b>	<b>4,3A+</b>	<b>4,6A++</b>	<b>4,4A+</b>	<b>4,3</b>	<b>4,2</b>	
Pdesign	at -10 °C	kW	3,6	4,0	6,0	5,2	8,0	9,5	10,6	
Input power heating		kW	0,84	1,34	1,69	2,00	2,60	3,48	4,38	
Annual energy consumption <sup>3)</sup>		kWh/a	1172	1500	1953	1582	2545	—	—	
Indoor unit			S-36PF1E5B	S-50PF1E5B	S-60PF1E5B	S-71PF1E5B	S-100PF1E5B	S-125PF1E5B	S-140PF1E5B	
External static pressure <sup>4)</sup>	Nominal (Min - Max)	Pa	70(10 - 150)	70(10 - 150)	70(10 - 150)	70(10 - 150)	100(10 - 150)	100(10 - 150)	100(10 - 150)	
Air volume	Hi / Med / Lo	m <sup>3</sup> /min	14,0/13,0/10,0	16,0/15,0/12,0	21,0/19,0/15,0	21,0/19,0/15,0	32,0/26,0/21,0	34,0/29,0/23,0	36,0/32,0/25,0	
Sound pressure <sup>5)</sup>	Hi / Med / Lo	dB(A)	33/29/25	34/30/26	35/32/26	35/32/26	38/34/31	39/35/32	40/36/33	
Dimension	HxWxD	mm	290x800x700	290x800x700	290x1000x700	290x1000x700	290x1400x700	290x1400x700	290x1400x700	
Net weight		kg	28	28	33	33	45	45	45	
Outdoor unit			U-36PZH2E5	U-50PZH2E5	U-60PZH2E5	U-71PZH2E5	U-100PZH2E5	U-125PZH2E5	U-140PZH2E5	
Power source		V	220 - 230 - 240	220 - 230 - 240	220 - 230 - 240	220 - 230 - 240	220 - 230 - 240	220 - 230 - 240	220 - 230 - 240	
Current	Cool	A	3,45 - 3,30 - 3,15	5,50 - 5,25 - 5,05	7,65 - 7,30 - 7,00	8,35 - 8,00 - 7,65	10,60 - 10,20 - 9,75	15,90 - 15,20 - 14,60	19,50 - 18,60 - 17,80	
	Heat	A	3,85 - 3,70 - 3,55	6,05 - 5,80 - 5,55	7,95 - 7,60 - 7,25	8,90 - 8,50 - 8,25	11,50 - 11,00 - 10,50	15,60 - 14,90 - 14,30	19,90 - 19,00 - 18,20	
Air volume	Cool / Heat	m <sup>3</sup> /min	40/40	40/45	40/45	61/60	118/108	125/122	129/116	
Sound pressure	Cool / Heat (Hi)	dB(A)	43/44	45/48	46/49	48/50	52/52	53/53	54/54	
Sound power	Cool / Heat (Hi)	dB(A)	62/64	64/68	65/69	65/67	69/69	70/70	71/71	
Dimension	HxWxD	mm	695x875x320	695x875x320	695x875x320	996x940x340	1416x940x340	1416x940x340	1416x940x340	
Net weight		kg	43	43	44	68	99	99	99	
Piping connections	Liquid pipe	Inch (mm)	1/4(6,35)	1/4(6,35)	3/8(9,52)	3/8(9,52)	3/8(9,52)	3/8(9,52)	3/8(9,52)	
	Gas pipe	Inch (mm)	1/2(12,70)	1/2(12,70)	5/8(15,88)	5/8(15,88)	5/8(15,88)	5/8(15,88)	5/8(15,88)	
Pipe length range		m	3 - 40	3 - 40	3 - 40	5 - 50	5 - 85	5 - 85	5 - 85	
Elevation difference (in/out) <sup>6)</sup>		m	30	30	30	30	30	30	30	
Pipe length for additional gas		m	30	30	30	30	30	30	30	
Additional gas amount		g/m	20	20	35	45	45	45	45	
Refrigerant (R32) / CO <sub>2</sub> Eq.		kg / T	1,15/0,776	1,15/0,776	1,45/0,979	1,95/1,316	3,05/2,059	3,05/2,059	3,05/2,059	
Operating range	Cool Min ~ Max	°C	-15 ~ +46	-15 ~ +46	-15 ~ +46	-15 ~ +46	-20 <sup>7)</sup> ~ +46	-20 <sup>7)</sup> ~ +46	-20 <sup>7)</sup> ~ +46	
	Heat Min ~ Max	°C	-20 ~ +24	-20 ~ +24	-20 ~ +24	-20 ~ +24	-20 ~ +24	-20 ~ +24	-20 ~ +24	

### Accessories

<b>CZ-RTC6</b>	<b>NEW</b> Wired remote controller (non-wireless)
<b>CZ-RTC6BL</b>	<b>NEW</b> Wired remote controller with Bluetooth®
<b>CZ-RTC5B</b>	Wired remote controller with Econavi function and datanavi
<b>CZ-RWS3 + CZ-RWRC3</b>	Infrared remote controller
<b>CZ-CAPWFC1</b>	Commercial Wi-Fi Adaptor
<b>PAW-WTRAY</b>	Tray for condenser water compatible with outdoor elevation platform

### Accessories

<b>PAW-GRDBSE20</b>	Outdoor base ground support for noise and vibration absorption
<b>PAW-GRDSTD40</b>	Outdoor elevation platform 400x900x400 mm
<b>CZ-CENSC1</b>	Econavi energy savings sensor
<b>CZ-56DAF2</b>	Air Outlet Plenum S . .PF1E5B 36, 45 & 50
<b>CZ-90DAF2</b>	Air Outlet Plenum S . .PF1E5B 60 & 71
<b>CZ-160DAF2</b>	Air Outlet Plenum S . .PF1E5B 100, 125 & 140
<b>CZ-DUMPA90MF2</b>	Air Inlet Plenum S . .PF1E5B 60 & 71
<b>CZ-DUMPA160MF2</b>	Air Inlet Plenum S . .PF1E5B 100, 125 & 140



**CZ-RTC6**  
**CZ-RTC6BL**  
Optional Controller.  
Wired remote controller.



**CZ-RWS3 +**  
**CZ-RWRC3**  
Optional Controller.  
Infrared remote controller.



**CZ-CENSC1**  
Optional Econavi  
Sensor.



## PACi Elite High Static Pressure Hide Away Inverter+ • R32 refrigerant

		Three Phase				
		7,1 kW	10,0 kW	12,5 kW	14,0 kW	
KIT		KIT-71PF1ZH8	KIT-100PF1ZH8	KIT-125PF1ZH8	KIT-140PF1ZH8	
Remote controller		CZ-RTC5B	CZ-RTC5B	CZ-RTC5B	CZ-RTC5B	
Cooling capacity	Nominal (Min - Max)	kW	7,1 [2,2 - 9,0]	10,0 [3,1 - 12,5]	12,5 [3,2 - 14,0]	14,0 [3,3 - 16,0]
EER <sup>1)</sup>		W/W	3,84	4,13	3,52	3,26
SEER <sup>2)</sup>			<b>6,4 A++</b>	<b>6,1 A++</b>	<b>5,9</b>	<b>5,7</b>
Pdesign		kW	7,1	10,0	12,5	14,0
Input power cooling		kW	1,85	2,42	3,55	4,30
Annual energy consumption <sup>3)</sup>		kWh/a	388	574	—	—
Heating capacity	Nominal (Min - Max)	kW	8,0 [2,0 - 9,0]	11,2 [3,1 - 14,0]	14,0 [3,2 - 16,0]	16,0 [3,3 - 18,0]
COP <sup>1)</sup>		W/W	4,00	4,31	4,02	3,65
SCOP <sup>2)</sup>			<b>4,6 A++</b>	<b>4,4 A+</b>	<b>4,3</b>	<b>4,2</b>
Pdesign at -10 °C		kW	5,2	8,0	9,5	10,6
Input power heating		kW	2,00	2,60	3,48	4,38
Annual energy consumption <sup>3)</sup>		kWh/a	1582	2545	—	—
<b>Indoor unit</b>			<b>S-71PF1E5B</b>	<b>S-100PF1E5B</b>	<b>S-125PF1E5B</b>	<b>S-140PF1E5B</b>
External static pressure <sup>4)</sup>	Nominal (Min - Max)	Pa	70 [10 - 150]	100 [10 - 150]	100 [10 - 150]	100 [10 - 150]
Air volume	Hi / Med / Lo	m <sup>3</sup> /min	21,0/19,0/15,0	32,0/26,0/21,0	34,0/29,0/23,0	36,0/32,0/25,0
Sound pressure <sup>5)</sup>	Hi / Med / Lo	dB(A)	35/32/26	38/34/31	39/35/32	40/36/33
Dimension	HxWxD	mm	290x1000x700	290x1400x700	290x1400x700	290x1400x700
Net weight		kg	33	45	45	45
<b>Outdoor unit</b>			<b>U-71PZH2E8</b>	<b>U-100PZH2E8</b>	<b>U-125PZH2E8</b>	<b>U-140PZH2E8</b>
Power source		V	380 - 400 - 415	380 - 400 - 415	380 - 400 - 415	380 - 400 - 415
Current	Cool	A	2,80 - 2,70 - 2,60	3,60 - 3,40 - 3,30	5,40 - 5,10 - 4,95	6,60 - 6,25 - 6,05
	Heat	A	3,00 - 2,90 - 2,80	3,90 - 3,70 - 3,55	5,30 - 5,00 - 4,85	6,70 - 6,40 - 6,15
Air volume	Cool / Heat	m <sup>3</sup> /min	61/60	118/108	125/112	129/116
Sound pressure	Cool / Heat (Hi)	dB(A)	48/50	52/52	53/53	54/54
Sound power	Cool / Heat (Hi)	dB(A)	65/67	69/69	70/70	71/71
Dimension	HxWxD	mm	996x940x340	1416x940x340	1416x940x340	1416x940x340
Net weight		kg	68	99	99	99
Piping connections	Liquid pipe	Inch (mm)	3/8 [9,52]	3/8 [9,52]	3/8 [9,52]	3/8 [9,52]
	Gas pipe	Inch (mm)	5/8 [15,88]	5/8 [15,88]	5/8 [15,88]	5/8 [15,88]
Pipe length range		m	5 - 50	5 - 85	5 - 85	5 - 85
Elevation difference (in/out) <sup>6)</sup>		m	30	30	30	30
Pipe length for additional gas		m	30	30	30	30
Additional gas amount		g/m	45	45	45	45
Refrigerant [R32] / CO <sub>2</sub> Eq.		kg / T	1,95 / 1,316	3,05 / 2,059	3,05 / 2,059	3,05 / 2,059
Operating range	Cool Min ~ Max	°C	-15 ~ +46	-20 <sup>7)</sup> ~ +46	-20 <sup>7)</sup> ~ +46	-20 <sup>7)</sup> ~ +46
	Heat Min ~ Max	°C	-20 ~ +24	-20 ~ +24	-20 ~ +24	-20 ~ +24

1) EER and COP calculation is based in accordance to EN14511. 2) Energy Label Scale from A+++ to D. For models below 12 kW, the SEER and SCOP is calculated based on values of EU/626/2011. For models above 12 kW, the SEER and SCOP is calculated based on values of EU/2281/2016. 3) The annual energy consumption is calculated in accordance to EU/626/2011. 4) Medium External static pressure setting from factory. 5) The sound pressure of the units shows the value measured of the position 1,5 m below the unit. The sound pressure is measured in accordance with Eurovent 6/C/006-97 specification. 6) When installing the outdoor unit at a higher position than the indoor unit. 7) For models 100 ~ 140PZH2E5[8], it is possible to operate the lowest -20 °C in the computer rooms with the piping length of 30 m or less. \* Recommended fuse for the indoor 3 A.



SEER and SCOP: For KIT-71PF1ZH5. INTERNET CONTROL: Optional.

Compatible with all Panasonic connectivity solutions. For detailed information go to the Control Systems section.



## PACi Standard High Static Pressure Hide Away Inverter+ • R32 refrigerant

			Single Phase					
			6,0 kW	7,1 kW	10,0 kW	12,5 kW	14,0 kW	
KIT			KIT-60PF1Z5	KIT-71PF1Z5	KIT-100PF1Z5	KIT-125PF1Z5	KIT-140PF1Z5	
Remote controller			CZ-RTC5B	CZ-RTC5B	CZ-RTC5B	CZ-RTC5B	CZ-RTC5B	
Cooling capacity	Nominal (Min - Max)	kW	6,0(2,0 - 7,1)	7,1(2,0 - 7,7)	10,0(3,0 - 11,5)	12,5(3,2 - 13,5)	14,0(3,3 - 15,0)	
EER <sup>1)</sup>	Nominal (Min - Max)	W/W	3,51	3,23	3,66(5,36 - 2,81)	3,52(5,33 - 2,80)	3,18(5,32 - 2,70)	
<b>SEER <sup>2)</sup></b>			<b>6,1 A++</b>	<b>6,1 A++</b>	<b>5,6 A+</b>	<b>5,6</b>	<b>5,4</b>	
P <sub>design</sub>		kW	6,0	7,1	10,0	12,5	14,0	
Input power cooling	Nominal (Min - Max)	kW	1,71	2,20	2,73(0,56 - 4,09)	3,55(0,60 - 4,82)	4,40(0,62 - 5,56)	
Annual energy consumption <sup>3)</sup>		kWh/a	344	407	625	787	911	
Heating capacity	Nominal (Min - Max)	kW	6,0(1,8 - 7,0)	7,1(1,8 - 8,1)	10,0(3,0 - 14,0)	12,5(3,3 - 15,0)	14,0(3,4 - 16,0)	
COP <sup>1)</sup>	Nominal (Min - Max)	W/W	4,55	4,13	4,31(5,36 - 3,51)	4,02(5,50 - 3,45)	3,79(5,48 - 3,13)	
<b>SCOP <sup>2)</sup></b>			<b>4,2 A+</b>	<b>4,3 A+</b>	<b>3,8 A</b>	<b>3,6</b>	<b>3,5</b>	
P <sub>design</sub> at -10 °C		kW	6,0	6,0	10,0	12,5	13,6	
Input power heating	Nominal (Min - Max)	kW	1,32	1,72	2,32(0,56 - 3,99)	3,11(0,60 - 4,35)	3,69(0,62 - 5,12)	
Annual energy consumption <sup>3)</sup>		kWh/a	2000	1953	3684	4848	5379	
Indoor unit			S-60PF1E5B	S-71PF1E5B	S-100PF1E5B	S-125PF1E5B	S-140PF1E5B	
External static pressure <sup>4)</sup>	Nominal (Min - Max)	Pa	70(10 - 150)	70(10 - 150)	100(10 - 150)	100(10 - 150)	100(10 - 150)	
Air volume	Hi / Med / Lo	m <sup>3</sup> /min	21,0/19,0/15,0	21,0/19,0/15,0	32,0/26,0/21,0	34,0/29,0/23,0	36,0/32,0/25,0	
Moisture removal volume		L/h	3,4	4,2	6,0	7,9	9,0	
Sound pressure <sup>5)</sup>	Hi / Med / Lo	dB(A)	35/32/26	35/32/26	38/34/31	39/35/32	40/36/33	
Sound power	Hi / Med / Lo	dB(A)	57/54/48	57/54/48	60/56/53	61/57/54	62/58/55	
Dimension	HxWxD	mm	290x1000x700	290x1000x700	290x1400x700	290x1400x700	290x1400x700	
Net weight		kg	33	33	45	45	45	
Outdoor unit			U-60PZ2E5	U-71PZ2E5	U-100PZ2E5	U-125PZ2E5	U-140PZ2E5	
Power source		V	220 - 230 - 240	220 - 230 - 240	220 - 230 - 240	220 - 230 - 240	220 - 230 - 240	
Current	Cool	A	8,05 - 7,70 - 7,35	10,40 - 9,95 - 9,50	12,10 - 11,60 - 11,10	16,10 - 15,50 - 14,80	20,20 - 19,30 - 18,60	
	Heat	A	6,05 - 5,80 - 5,55	8,10 - 7,75 - 7,40	10,10 - 9,70 - 9,30	14,00 - 13,40 - 12,90	16,80 - 16,00 - 15,30	
Air volume	Cool / Heat	m <sup>3</sup> /min	40/45	50/45	76/70	86/78	89/83	
Sound pressure	Cool / Heat (Hi)	dB(A)	46/48	49/49	52/52	55/55	56/56	
Sound power	Cool / Heat (Hi)	dB(A)	65/68	69/69	70/70	73/73	74/74	
Dimension	HxWxD	mm	695x875x320	695x875x320	996x980x370	996x980x370	996x980x370	
Net weight		kg	44	44	90	94	94	
Piping connections	Liquid pipe	Inch (mm)	3/8(9,52)	3/8(9,52)	3/8(9,52)	3/8(9,52)	3/8(9,52)	
	Gas pipe	Inch (mm)	5/8(15,88)	5/8(15,88)	5/8(15,88)	5/8(15,88)	5/8(15,88)	
Pipe length range		m	3 - 40	3 - 40	5 - 50	5 - 50	5 - 50	
Elevation difference (in/out) <sup>6)</sup>		m	30	30	30	30	30	
Pipe length for additional gas		m	30	30	30	30	30	
Additional gas amount		g/m	35	35	45	45	45	
Refrigerant (R32) / CO <sub>2</sub> Eq.		kg / T	1,45/0,979	1,45/0,979	2,60/1,755	2,98/2,0115	2,98/2,0115	
Operating range	Cool Min ~ Max	°C	-10 ~ +43	-10 ~ +43	-10 ~ +43	-10 ~ +43	-10 ~ +43	
	Heat Min ~ Max	°C	-15 ~ +24	-15 ~ +24	-15 ~ +24	-15 ~ +24	-15 ~ +24	

### Accessories

<b>CZ-RTC6</b>	<b>NEW</b> Wired remote controller (non-wireless)
<b>CZ-RTC6BL</b>	<b>NEW</b> Wired remote controller with Bluetooth®
<b>CZ-RTC5B</b>	Wired remote controller with Econavi function and datanavi
<b>CZ-RWS3 + CZ-RWRC3</b>	Infrared remote controller
<b>CZ-CAPWFC1</b>	Commercial Wi-Fi Adaptor
<b>PAW-WTRAY</b>	Tray for condenser water compatible with outdoor elevation platform

### Accessories

<b>PAW-GRDBSE20</b>	Outdoor base ground support for noise and vibration absorption
<b>PAW-GRDSTD40</b>	Outdoor elevation platform 400x900x400 mm
<b>CZ-CENSC1</b>	Econavi energy savings sensor
<b>CZ-90DAF2</b>	Air Outlet Plenum S . .PF1E5B 60 & 71
<b>CZ-160DAF2</b>	Air Outlet Plenum S . .PF1E5B 100, 125 & 140
<b>CZ-DUMPA90MF2</b>	Air Inlet Plenum S . .PF1E5B 60 & 71
<b>CZ-DUMPA160MF2</b>	Air Inlet Plenum S . .PF1E5B 100, 125 & 140



**CZ-RTC6**  
**CZ-RTC6BL**  
Optional Controller.  
Wired remote controller.



**CZ-RWS3 +**  
**CZ-RWRC3**  
Optional Controller.  
Infrared remote controller.



**CZ-CENSC1**  
Optional Econavi  
Sensor.



## PACi Standard High Static Pressure Hide Away Inverter+ • R32 refrigerant

			Three Phase		
			10,0 kW	12,5 kW	14,0 kW
<b>KIT</b>			<b>KIT-100PF1Z8</b>	<b>KIT-125PF1Z8</b>	<b>KIT-140PF1Z8</b>
<b>Remote controller</b>			<b>CZ-RTC5B</b>	<b>CZ-RTC5B</b>	<b>CZ-RTC5B</b>
Cooling capacity	Nominal (Min - Max)	kW	10,0(3,0 - 11,5)	12,5(3,2 - 13,5)	14,0(3,3 - 15,0)
EER <sup>1)</sup>	Nominal (Min - Max)	W/W	3,66(5,36 - 2,81)	3,52(5,33 - 2,80)	3,18(5,32 - 2,70)
<b>SEER <sup>2)</sup></b>			<b>5,6 A+</b>	<b>5,6</b>	<b>5,4</b>
Pdesign		kW	10,0	12,5	14,0
Input power cooling	Nominal (Min - Max)	kW	2,73(0,56 - 4,09)	3,55(0,60 - 4,82)	4,40(0,62 - 5,56)
Annual energy consumption <sup>3)</sup>		kWh/a	625	790	912
Heating capacity	Nominal (Min - Max)	kW	10,0(3,0 - 14,0)	12,5(3,3 - 15,0)	14,0(3,4 - 16,0)
COP <sup>1)</sup>	Nominal (Min - Max)	W/W	4,31(5,36 - 3,51)	4,02(5,50 - 3,45)	3,79(5,48 - 3,13)
<b>SCOP <sup>2)</sup></b>			<b>3,8 A</b>	<b>3,6</b>	<b>3,5</b>
Pdesign at -10 °C		kW	10,0	12,5	13,6
Input power heating	Nominal (Min - Max)	kW	2,32(0,56 - 3,99)	3,11(0,60 - 4,35)	3,69(0,62 - 5,12)
Annual energy consumption <sup>3)</sup>		kWh/a	3684	4848	5379
<b>Indoor unit</b>			<b>S-100PF1E5B</b>	<b>S-125PF1E5B</b>	<b>S-140PF1E5B</b>
External static pressure <sup>4)</sup>	Nominal (Min - Max)	Pa	100(10 - 150)	100(10 - 150)	100(10 - 150)
Air volume	Hi / Med / Lo	m <sup>3</sup> /min	32,0/26,0/21,0	34,0/29,0/23,0	36,0/32,0/25,0
Moisture removal volume		L/h	6,0	7,9	9,0
Sound pressure <sup>5)</sup>	Hi / Med / Lo	dB(A)	38/34/31	39/35/32	40/36/33
Sound power	Hi / Med / Lo	dB(A)	60/56/53	61/57/54	62/58/55
Dimension	H x W x D	mm	290 x 1400 x 700	290 x 1400 x 700	290 x 1400 x 700
Net weight		kg	45	45	45
<b>Outdoor unit</b>			<b>U-100PZ2E8</b>	<b>U-125PZ2E8</b>	<b>U-140PZ2E8</b>
Power source		V	380 - 400 - 415	380 - 400 - 415	380 - 400 - 415
Current	Cool	A	4,15 - 3,95 - 3,80	5,40 - 5,10 - 4,95	6,75 - 6,40 - 6,15
	Heat	A	3,45 - 3,30 - 3,20	4,70 - 4,45 - 4,30	5,60 - 5,30 - 5,15
Air volume	Cool / Heat	m <sup>3</sup> /min	76/70	86/78	89/83
Sound pressure	Cool / Heat (Hi)	dB(A)	52/52	55/55	56/56
Sound power	Cool / Heat (Hi)	dB(A)	70/70	73/73	74/74
Dimension	H x W x D	mm	996 x 980 x 370	996 x 980 x 370	996 x 980 x 370
Net weight		kg	90	94	94
Piping connections	Liquid pipe	Inch (mm)	3/8(9,52)	3/8(9,52)	3/8(9,52)
	Gas pipe	Inch (mm)	5/8(15,88)	5/8(15,88)	5/8(15,88)
Pipe length range		m	5 - 50	5 - 50	5 - 50
Elevation difference (in/out) <sup>6)</sup>		m	30	30	30
Pipe length for additional gas		m	30	30	30
Additional gas amount		g/m	45	45	45
Refrigerant (R32) / CO <sub>2</sub> Eq.		kg / T	2,60/1,755	2,98/2,0115	2,98/2,0115
Operating range	Cool Min ~ Max	°C	-10 ~ +43	-10 ~ +43	-10 ~ +43
	Heat Min ~ Max	°C	-15 ~ +24	-15 ~ +24	-15 ~ +24

1) EER and COP calculation is based in accordance to EN14511. 2) Energy Label Scale from A+++ to D. For models below 12 kW, the SEER and SCOP is calculated based on values of EU/626/2011. For models above 12 kW, the SEER and SCOP is calculated based on values of EU/2281/2016. 3) The annual energy consumption is calculated in accordance to EU/626/2011. 4) Medium External static pressure setting from factory. 5) The sound pressure of the units shows the value measured of the position 1,5 m below the unit. The sound pressure is measured in accordance with Eurovent 6/C/006-97 specification. 6) When installing the outdoor unit at a higher position than the indoor unit. \* Recommended fuse for the indoor 3 A.



SEER and SCOP: For KIT-71PF1Z5. INTERNET CONTROL: Optional.  
Compatible with all Panasonic connectivity solutions. For detailed information go to the Control Systems section.



CZ-RTC5B

## PACi Elite Low Static Pressure Hide Away Inverter+ • R32 refrigerant

			Single Phase						
			3,6 kW	5,0 kW	6,0 kW	7,1 kW	10,0 kW	12,5 kW	14,0 kW
KIT			KIT-36PN1ZH5	KIT-50PN1ZH5	KIT-60PN1ZH5	KIT-71PN1ZH5	KIT-100PN1ZH5	KIT-125PN1ZH5	KIT-140PN1ZH5
Remote controller			CZ-RTC5B	CZ-RTC5B	CZ-RTC5B	CZ-RTC5B	CZ-RTC5B	CZ-RTC5B	CZ-RTC5B
Cooling capacity	Nominal (Min - Max)	kW	3,6(1,5 - 4,0)	5,0(1,5 - 5,6)	6,0(2,0 - 7,1)	7,1(2,0 - 9,0)	10,0(3,1 - 12,5)	12,5(3,2 - 14,0)	14,0(3,3 - 16,0)
EER <sup>1)</sup>		W/W	3,85	3,40	3,41	3,40	3,95	3,35	3,15
<b>SEER<sup>2)</sup></b>			<b>5,1A</b>	<b>5,1A</b>	<b>6,0A+</b>	<b>6,0A+</b>	<b>6,0A+</b>	<b>6,0</b>	<b>5,8</b>
Pdesign		kW	3,6	5,0	6,0	7,1	10,0	12,5	14,0
Input power cooling		kW	0,93	1,47	1,76	2,09	2,53	3,73	4,45
Annual energy consumption <sup>3)</sup>		kWh/a	246	342	350	414	582	—	—
Heating capacity	Nominal (Min - Max)	kW	4,0(1,5 - 5,0)	5,6(1,5 - 6,5)	7,0(1,8 - 7,0)	8,0(2,0 - 9,0)	11,2(3,1 - 14,0)	14,0(3,3 - 16,0)	16,0(3,3 - 18,0)
COP <sup>1)</sup>		W/W	4,40	3,50	3,80	3,90	4,00	3,70	3,50
<b>SCOP<sup>2)</sup></b>			<b>4,0A+</b>	<b>4,0A+</b>	<b>4,0A+</b>	<b>4,0A+</b>	<b>4,0A+</b>	<b>3,9</b>	<b>3,8</b>
Pdesign at -10 °C		kW	3,6	3,8	5,6	5,2	8,0	9,5	10,6
Input power heating		kW	0,91	1,60	1,84	2,05	2,80	3,78	4,45
Annual energy consumption <sup>3)</sup>		kWh/a	1258	1573	2095	1914	2799	—	—
Indoor unit			S-36PN1E5B	S-50PN1E5B	S-60PN1E5B	S-71PN1E5B	S-100PN1E5B	S-125PN1E5B	S-140PN1E5B
External static pressure <sup>4)</sup>	Nominal (Min - Max)	Pa	25(10 - 80)	25(10 - 80)	25(10 - 80)	25(10 - 80)	40(10 - 80)	50(10 - 80)	50(10 - 80)
Air volume	Hi / Med / Lo	m <sup>3</sup> /min	14,0/12,0/10,0	16,0/13,0/10,0	22,0/20,0/16,0	22,0/20,0/16,0	36,0/33,0/26,0	38,0/35,0/28,0	40,0/37,0/30,0
Sound pressure <sup>5)</sup>	Hi / Med / Lo	dB(A)	35/33/30	36/34/30	38/36/31	38/36/31	39/37/32	40/38/33	41/39/34
Dimension	HxWxD	mm	250x780x650	250x780x650	250x1000x650	250x1000x650	250x1200x650	250x1200x650	250x1200x650
Net weight		kg	29	29	32	32	41	41	41
Outdoor unit			U-36PZH2E5	U-50PZH2E5	U-60PZH2E5	U-71PZH2E5	U-100PZH2E5	U-125PZH2E5	U-140PZH2E5
Power source		V	220 - 230 - 240	220 - 230 - 240	220 - 230 - 240	220 - 230 - 240	220 - 230 - 240	220 - 230 - 240	220 - 230 - 240
Current	Cool	A	4,20 - 4,00 - 3,85	6,50 - 6,20 - 5,95	8,20 - 7,85 - 7,50	9,45 - 9,00 - 8,60	11,20 - 10,70 - 10,20	16,90 - 16,10 - 15,40	20,00 - 19,30 - 18,40
	Heat	A	4,10 - 3,90 - 3,75	7,15 - 6,85 - 6,55	8,60 - 8,25 - 7,85	9,20 - 8,85 - 8,45	2,40 - 11,90 - 11,40	17,00 - 16,20 - 15,60	20,20 - 19,30 - 18,50
Air volume	Cool / Heat	m <sup>3</sup> /min	40/40	40/45	40/45	61/60	118/108	125/122	129/116
Sound pressure	Cool / Heat (Hi)	dB(A)	43/44	45/48	46/49	48/50	52/52	53/53	54/54
Sound power	Cool / Heat (Hi)	dB(A)	62/64	64/68	65/69	65/67	69/69	70/70	71/71
Dimension	HxWxD	mm	695x875x320	695x875x320	695x875x320	996x940x340	1416x940x340	1416x940x340	1416x940x340
Net weight		kg	43	43	44	68	99	99	99
Piping connections	Liquid pipe	Inch (mm)	1/4(6,35)	1/4(6,35)	3/8(9,52)	3/8(9,52)	3/8(9,52)	3/8(9,52)	3/8(9,52)
	Gas pipe	Inch (mm)	1/2(12,70)	1/2(12,70)	5/8(15,88)	5/8(15,88)	5/8(15,88)	5/8(15,88)	5/8(15,88)
Pipe length range		m	3 - 40	3 - 40	3 - 40	5 - 50	5 - 85	5 - 85	5 - 85
Elevation difference (in/out) <sup>6)</sup>		m	30	30	30	30	30	30	30
Pipe length for additional gas		m	30	30	30	30	30	30	30
Additional gas amount		g/m	20	20	35	45	45	45	45
Refrigerant (R32) / CO <sub>2</sub> Eq.		kg / T	1,15/0,776	1,15/0,776	1,45/0,979	1,95/1,316	3,05/2,059	3,05/2,059	3,05/2,059
Operating range	Cool Min ~ Max	°C	-15 ~ +46	-15 ~ +46	-15 ~ +46	-15 ~ +46	-20 <sup>7)</sup> ~ +46	-20 <sup>7)</sup> ~ +46	-20 <sup>7)</sup> ~ +46
	Heat Min ~ Max	°C	-20 ~ +24	-20 ~ +24	-20 ~ +24	-20 ~ +24	-20 ~ +24	-20 ~ +24	-20 ~ +24

### Accessories

<b>CZ-RTC6</b>	<b>NEW</b> Wired remote controller (non-wireless)
<b>CZ-RTC6BL</b>	<b>NEW</b> Wired remote controller with Bluetooth®
<b>CZ-RTC5B</b>	Wired remote controller with Econavi function and datanavi
<b>CZ-RWS3 + CZ-RWRC3</b>	Infrared remote controller
<b>CZ-CAPWFC1</b>	Commercial Wi-Fi Adaptor

### Accessories

<b>PAW-WTRAY</b>	Tray for condenser water compatible with outdoor elevation platform
<b>PAW-GRDBSE20</b>	Outdoor base ground support for noise and vibration absorption
<b>PAW-GRDSTD40</b>	Outdoor elevation platform 400x900x400 mm
<b>CZ-CENSC1</b>	Econavi energy savings sensor



**CZ-RTC6**  
**CZ-RTC6BL**  
Optional Controller.  
Wired remote controller.



**CZ-RWS3 +**  
**CZ-RWRC3**  
Optional Controller.  
Infrared remote controller.



**CZ-CENSC1**  
Optional Econavi  
Sensor.



## PACi Elite Low Static Pressure Hide Away Inverter+ • R32 refrigerant

			Three Phase			
			7,1 kW	10,0 kW	12,5 kW	14,0 kW
KIT			KIT-71PN1ZH8	KIT-100PN1ZH8	KIT-125PN1ZH8	KIT-140PN1ZH8
Remote controller			CZ-RTC5B	CZ-RTC5B	CZ-RTC5B	CZ-RTC5B
Cooling capacity	Nominal (Min - Max)	kW	7,1 [2,2 - 9,0]	10,0 [3,1 - 12,5]	12,5 [3,2 - 14,0]	14,0 [3,3 - 16,0]
EER <sup>1)</sup>		W/W	3,40	3,95	3,35	3,15
SEER <sup>2)</sup>			<b>5,9 A+</b>	<b>5,9 A+</b>	<b>5,9</b>	<b>5,8</b>
Pdesign		kW	7,1	10,0	12,5	14,0
Input power cooling		kW	2,09	2,53	3,73	4,45
Annual energy consumption <sup>3)</sup>		kWh/a	418	588	—	—
Heating capacity	Nominal (Min - Max)	kW	8,0 [2,0 - 9,0]	11,2 [3,1 - 14,0]	14,0 [3,3 - 16,0]	16,0 [3,3 - 18,0]
COP <sup>1)</sup>		W/W	3,90	4,00	3,70	3,60
SCOP <sup>2)</sup>			<b>4,0 A+</b>	<b>4,0 A+</b>	<b>3,9</b>	<b>3,8</b>
Pdesign at -10 °C		kW	5,2	8,0	9,5	10,6
Input power heating		kW	2,05	2,80	3,78	4,45
Annual energy consumption <sup>3)</sup>		kWh/a	1914	2799	—	—
Indoor unit			S-71PN1E5B	S-100PN1E5B	S-125PN1E5B	S-140PN1E5B
External static pressure <sup>4)</sup>	Nominal (Min - Max)	Pa	25 [10 - 80]	40 [10 - 80]	50 [10 - 80]	50 [10 - 80]
Air volume	Hi / Med / Lo	m <sup>3</sup> /min	22,0/20,0/16,0	36,0/33,0/26,0	38,0/35,0/28,0	46,0/37,0/30,0
Sound pressure <sup>5)</sup>	Hi / Med / Lo	dB(A)	38/36/31	39/37/32	40/38/33	41/39/34
Dimension	HxWxD	mm	250x1000x650	250x1200x650	250x1200x650	250x1200x650
Net weight		kg	32	41	41	41
Outdoor unit			U-71PZH2E8	U-100PZH2E8	U-125PZH2E8	U-140PZH2E8
Power source		V	380 - 400 - 415	380 - 400 - 415	380 - 400 - 415	380 - 400 - 415
Current	Cool	A	3,20 - 3,05 - 2,95	3,75 - 3,55 - 3,45	5,65 - 5,40 - 5,20	11,70 - 11,20 - 10,70
	Heat	A	3,20 - 2,95 - 2,85	4,20 - 4,00 - 3,85	5,75 - 5,45 - 5,25	6,80 - 6,45 - 6,20
Air volume	Cool / Heat	m <sup>3</sup> /min	61/60	118/108	125/112	129/116
Sound pressure	Cool / Heat (Hi)	dB(A)	48/50	52/52	53/53	54/54
Sound power	Cool / Heat (Hi)	dB(A)	65/67	69/69	70/70	71/71
Dimension	HxWxD	mm	996x940x340	1416x940x340	1416x940x340	1416x940x340
Net weight		kg	68	99	99	99
Piping connections	Liquid pipe	Inch (mm)	3/8 [9,52]	3/8 [9,52]	3/8 [9,52]	3/8 [9,52]
	Gas pipe	Inch (mm)	5/8 [15,88]	5/8 [15,88]	5/8 [15,88]	5/8 [15,88]
Pipe length range		m	5 - 50	5 - 85	5 - 85	5 - 85
Elevation difference (in/out) <sup>6)</sup>		m	30	30	30	30
Pipe length for additional gas		m	30	30	30	30
Additional gas amount		g/m	45	45	45	45
Refrigerant [R32] / CO <sub>2</sub> Eq.		kg / T	1,95 / 1,316	3,05 / 2,059	3,05 / 2,059	3,05 / 2,059
Operating range	Cool Min ~ Max	°C	-15 ~ +46	-20 <sup>7)</sup> ~ +46	-20 <sup>7)</sup> ~ +46	-20 <sup>7)</sup> ~ +46
	Heat Min ~ Max	°C	-20 ~ +24	-20 ~ +24	-20 ~ +24	-20 ~ +24

1) EER and COP calculation is based in accordance to EN14511. 2) Energy Label Scale from A+++ to D. For models below 12 kW, the SEER and SCOP is calculated based on values of EU/626/2011. For models above 12 kW, the SEER and SCOP is calculated based on values of EU/2281/2016. 3) The annual energy consumption is calculated in accordance to EU/626/2011. 4) Medium external static pressure setting from factory. 5) The sound pressure of the units shows the value measured of the position 1,5 m below the unit. The sound pressure is measured in accordance with Eurovent 6/C/006-97 specification. 6) When installing the outdoor unit at a higher position than the indoor unit. 7) For models 100 ~ 140PZH2E5[8], it is possible to operate the lowest -20 °C in the computer rooms with the piping length of 30 m or less.  
\* Recommended fuse for the indoor 3 A.



SEER and SCOP: KIT-60PN1ZH5, KIT-71PN1ZH5 and KIT-100PN1ZH5. INTERNET CONTROL: Optional.  
Compatible with all Panasonic connectivity solutions. For detailed information go to the Control Systems section.



CZ-RTC5B

## PACi Standard Low Static Pressure Hide Away Inverter+ • R32 refrigerant

			Single Phase					
			6,0 kW	7,1 kW	10,0 kW	12,5 kW	14,0 kW	
KIT			KIT-60PN1Z5	KIT-71PN1Z5	KIT-100PN1Z5	KIT-125PN1Z5	KIT-140PN1Z5	
Remote controller			CZ-RTC5B	CZ-RTC5B	CZ-RTC5B	CZ-RTC5B	CZ-RTC5B	
Cooling capacity	Nominal (Min - Max)	kW	6,0(2,0 - 7,1)	7,1(2,0 - 7,7)	10,0(3,0 - 11,5)	12,5(3,2 - 13,5)	14,0(3,3 - 15,0)	
EER <sup>1)</sup>		W/W	3,31	3,11	3,30	3,20	3,00	
<b>SEER <sup>2)</sup></b>			<b>5,8 A+</b>	<b>5,8 A+</b>	<b>5,4 A</b>	<b>5,1</b>	<b>5,0</b>	
Pdesign		kW	6,0	7,1	10,0	12,5	14,0	
Input power cooling		kW	1,81	2,28	3,03	3,90	4,65	
Annual energy consumption <sup>3)</sup>		kWh/a	361	428	641	—	—	
Heating capacity	Nominal (Min - Max)	kW	6,0(1,8 - 7,0)	7,1(1,8 - 8,1)	10,0(3,0 - 14,0)	12,5(3,3 - 15,0)	14,0(3,4 - 16,0)	
COP <sup>1)</sup>		W/W	3,90	3,72	3,91	3,60	3,55	
<b>SCOP <sup>2)</sup></b>			<b>4,0 A+</b>	<b>4,0 A+</b>	<b>3,9 A</b>	<b>3,6</b>	<b>3,5</b>	
Pdesign at -10 °C		kW	5,6	5,6	7,6	12,5	14,0	
Input power heating		kW	1,54	1,90	2,56	3,46	3,94	
Annual energy consumption <sup>3)</sup>		kWh/a	2095	2100	3589	—	—	
Indoor unit			S-60PN1E5B	S-71PN1E5B	S-100PN1E5B	S-125PN1E5B	S-140PN1E5B	
External static pressure <sup>4)</sup>	Nominal (Min - Max)	Pa	25(10 - 80)	25(10 - 80)	40(10 - 80)	50(10 - 80)	50(10 - 80)	
Air volume	Hi / Med / Lo	m <sup>3</sup> /min	22,0/20,0/16,0	22,0/20,0/16,0	36,0/33,0/26,0	38,0/35,0/28,0	40,0/37,0/30,0	
Sound pressure <sup>5)</sup>	Hi / Med / Lo	dB(A)	38/36/31	38/36/31	39/37/32	40/38/33	41/39/34	
Dimension	HxWxD	mm	250x1000x650	250x1000x650	250x1200x650	250x1200x650	250x1200x650	
Net weight		kg	32	32	41	41	41	
Outdoor unit			U-60PZ2E5	U-71PZ2E5	U-100PZ2E5	U-125PZ2E5	U-140PZ2E5	
Power source		V	220 - 230 - 240	220 - 230 - 240	220 - 230 - 240	220 - 230 - 240	220 - 230 - 240	
Current	Cool	A	8,30 - 8,00 - 7,60	10,60 - 10,10 - 9,60	14,00 - 13,30 - 12,80	17,90 - 17,10 - 16,50	21,50 - 20,50 - 19,60	
	Heat	A	7,00 - 6,70 - 6,40	8,80 - 8,40 - 8,00	11,60 - 11,10 - 10,70	15,80 - 15,10 - 14,50	18,00 - 17,30 - 16,50	
Air volume	Cool / Heat	m <sup>3</sup> /min	40/45	50/45	76/70	86/78	89/83	
Sound pressure	Cool / Heat (Hi)	dB(A)	46/48	49/49	52/52	55/55	56/56	
Sound power	Cool / Heat (Hi)	dB(A)	65/68	69/69	70/70	73/73	74/74	
Dimension	HxWxD	mm	695x875x320	695x875x320	996x980x370	996x980x370	996x980x370	
Net weight		kg	44	44	90	94	94	
Piping connections	Liquid pipe	Inch (mm)	3/8(9,52)	3/8(9,52)	3/8(9,52)	3/8(9,52)	3/8(9,52)	
	Gas pipe	Inch (mm)	5/8(15,88)	5/8(15,88)	5/8(15,88)	5/8(15,88)	5/8(15,88)	
Pipe length range		m	3 - 40	3 - 40	5 - 50	5 - 50	5 - 50	
Elevation difference (in/out) <sup>6)</sup>		m	30	30	30	30	30	
Pipe length for additional gas		m	30	30	30	30	30	
Additional gas amount		g/m	35	35	45	45	45	
Refrigerant (R32) / CO <sub>2</sub> Eq.		kg / T	1,45/0,979	1,45/0,979	2,60/1,755	2,98/2,0115	2,98/2,0115	
Operating range	Cool Min - Max	°C	-10 ~ +43	-10 ~ +43	-10 ~ +43	-10 ~ +43	-10 ~ +43	
	Heat Min - Max	°C	-15 ~ +24	-15 ~ +24	-15 ~ +24	-15 ~ +24	-15 ~ +24	

### Accessories

<b>CZ-RTC6</b>	<b>NEW</b> Wired remote controller (non-wireless)
<b>CZ-RTC6BL</b>	<b>NEW</b> Wired remote controller with Bluetooth®
<b>CZ-RTC5B</b>	Wired remote controller with Econavi function and datanavi
<b>CZ-RWS3 + CZ-RWRC3</b>	Infrared remote controller
<b>CZ-CAPWFC1</b>	Commercial Wi-Fi Adaptor

### Accessories

<b>PAW-WTRAY</b>	Tray for condenser water compatible with outdoor elevation platform
<b>PAW-GRDBSE20</b>	Outdoor base ground support for noise and vibration absorption
<b>PAW-GRDSTD40</b>	Outdoor elevation platform 400x900x400 mm
<b>CZ-CENSC1</b>	Econavi energy savings sensor





**CZ-RTC6**  
**CZ-RTC6BL**  
Optional Controller.  
Wired remote controller.



**CZ-RWS3 +**  
**CZ-RWRC3**  
Optional Controller.  
Infrared remote controller.



**CZ-CENSC1**  
Optional Econavi  
Sensor.



## PACi Standard Low Static Pressure Hide Away Inverter+ • R32 refrigerant

			Three Phase		
			10,0 kW	12,5 kW	14,0 kW
KIT			KIT-100PN1Z8	KIT-125PN1Z8	KIT-140PN1Z8
Remote controller			CZ-RTC5B	CZ-RTC5B	CZ-RTC5B
Cooling capacity	Nominal (Min - Max)	kW	10,0(3,0 - 11,5)	12,5(3,2 - 13,5)	14,0(3,3 - 15,0)
EER <sup>1)</sup>		W/W	3,30	3,21	3,01
<b>SEER <sup>2)</sup></b>			<b>5,4A</b>	<b>5,1</b>	<b>5,0</b>
Pdesign		kW	10,0	12,5	14,0
Input power cooling		kW	3,03	3,90	4,65
Annual energy consumption <sup>3)</sup>		kWh/a	648	—	—
Heating capacity	Nominal (Min - Max)	kW	10,0(3,0 - 14,0)	12,5(3,3 - 15,0)	14,0(3,4 - 16,0)
COP <sup>1)</sup>		W/W	3,91	3,61	3,55
<b>SCOP <sup>2)</sup></b>			<b>3,9A</b>	<b>3,6</b>	<b>3,5</b>
Pdesign at -10 °C		kW	7,6	12,5	14,0
Input power heating		kW	2,56	3,46	3,94
Annual energy consumption <sup>3)</sup>		kWh/a	3589	—	—
Indoor unit			S-100PN1E5B	S-125PN1E5B	S-140PN1E5B
External static pressure <sup>4)</sup>	Nominal (Min - Max)	Pa	40(10 - 80)	50(10 - 80)	50(10 - 80)
Air volume	Hi / Med / Lo	m <sup>3</sup> /min	36,0/33,0/26,0	38,0/35,0/28,0	40,0/37,0/30,0
Sound pressure <sup>5)</sup>	Hi / Med / Lo	dB(A)	39/37/32	40/38/33	41/39/34
Dimension	HxWxD	mm	250x1200x650	250x1200x650	250x1200x650
Net weight		kg	41	41	41
Outdoor unit			U-100PZ2E8	U-125PZ2E8	U-140PZ2E8
Power source		V	380 - 400 - 415	380 - 400 - 415	380 - 400 - 415
Current	Cool	A	4,70 - 4,50 - 4,30	6,00 - 5,70 - 5,50	7,20 - 6,80 - 6,60
	Heat	A	3,90 - 3,70 - 3,60	5,30 - 5,00 - 4,90	6,00 - 5,70 - 5,50
Air volume	Cool / Heat	m <sup>3</sup> /min	76/70	86/78	89/83
Sound pressure	Cool / Heat (Hi)	dB(A)	52/52	55/55	56/56
Sound power	Cool / Heat (Hi)	dB(A)	70/70	73/73	74/74
Dimension	HxWxD	mm	996x980x370	996x980x370	996x980x370
Net weight		kg	90	94	94
Piping connections	Liquid pipe	Inch (mm)	3/8(9,52)	3/8(9,52)	3/8(9,52)
	Gas pipe	Inch (mm)	5/8(15,88)	5/8(15,88)	5/8(15,88)
Pipe length range		m	5 - 50	5 - 50	5 - 50
Elevation difference (in/out) <sup>6)</sup>		m	30	30	30
Pipe length for additional gas		m	30	30	30
Additional gas amount		g/m	45	45	45
Refrigerant (R32) / CO <sub>2</sub> Eq.		kg / T	2,60 / 1,755	2,98 / 2,0115	2,98 / 2,0115
Operating range	Cool Min ~ Max	°C	-10 ~ +43	-10 ~ +43	-10 ~ +43
	Heat Min ~ Max	°C	-15 ~ +24	-15 ~ +24	-15 ~ +24

1) EER and COP calculation is based in accordance to EN14511. 2) Energy Label Scale from A+++ to D. For models below 12 kW, the SEER and SCOP is calculated based on values of EU/626/2011. For models above 12 kW, the SEER and SCOP is calculated based on values of EU/2281/2016. 3) The annual energy consumption is calculated in accordance to EU/626/2011. 4) Medium external static pressure setting from factory. 5) The sound pressure of the units shows the value measured of the position 1,5 m below the unit. The sound pressure is measured in accordance with Eurovent 6/C/006-97 specification. 6) When installing the outdoor unit at a higher position than the indoor unit. \* Recommended fuse for the indoor 3 A.



SEER and SCOP: For KIT-60PN1Z5 and KIT-71PN1Z5. INTERNET CONTROL: Optional.  
Compatible with all Panasonic connectivity solutions. For detailed information go to the Control Systems section.

# Panasonic Big PACi Series R32

Panasonic Big PACi, not only environmental friendly but also a groundbreaking product. Big PACi with R32 has been introduced with full renewal of its indoor unit, offering hydronic application by PACi Water Heat Exchanger.

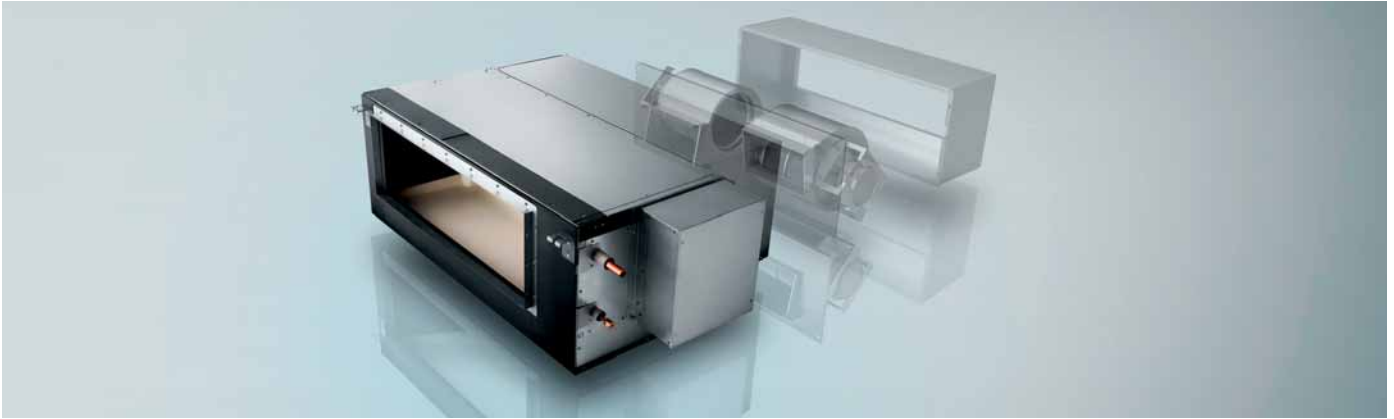

**1 Compact & light indoor body**  
Compact and light indoor body, keeping the high efficiency, has a split-able design for easy installation within a limited narrow space. Plus ease of maintenance due to the simplified disassembly design.

**2 Easy pipe work with split-able Hide Away indoor design**  
Heat exchanger and fan elements (fan + casing) can be separated during installation. The Hide Away indoor unit is easily reassembled and will fit through a narrow space.

### Compact and light indoor body, keeping high efficiency

15 % lighter weight vs conventional model drastically improves installation work.

	Conventional model	New
20,0 kW	100kg	86kg
25,0 kW	104kg	88kg

**DEPTH WAS REDUCED BY 230 mm**



**3 High external static pressure, maximum 200 Pa\* setting**  
A high static pressure enables the use of long ducts for installation in a wide range of spaces.  
\* S-250PE3E5B.

**4 Panasonic Comfort Cloud control**  
Ready to control PACi systems with Panasonic Comfort Cloud App in your smartphones.\*  
\* Panasonic Wi-Fi Adaptor CZ-CAPWFC1 is required.

### Maximum 200 Pa\* static pressure setting

A high static pressure enables the use of long ducts for installation in a wide range of spaces.

**3-step static pressure set up.**  
Selectable of static pressure modes can change 200 Pa / 130 Pa / 75Pa for extra installation flexibility.

\* In case of S-250PE3E5B.



### Easy installation with light components

Indoor unit can easily be split into 3 components, the heaviest of which weighs only 48kg.

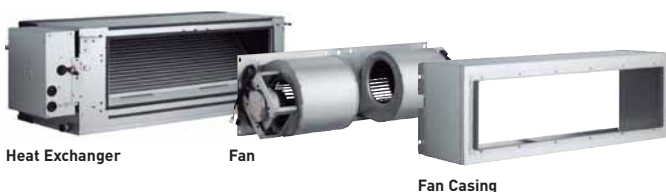

### Dimensions of each component (lightweight design for easy disassembly).



The weight is for S-200PE3E5B model.



CZ-RTC5B

CZ-RTC6  
CZ-RTC6BL  
Optional Controller.  
Wired remote controller.CZ-RWS3 +  
CZ-RWRC3  
Optional Controller.  
Infrared remote  
controller.CZ-CENSC1  
Optional Econavi  
Sensor.

## Big PACi High Static Pressure Hide Away 20,0-25,0 kW Inverter+ • R32 refrigerant

### Three Phase

			20,0 kW	25,0 kW
			KIT-200PE3ZH8	KIT-250PE3ZH8
			CZ-RTC5B	CZ-RTC5B
<b>KIT</b>				
<b>Remote controller</b>				
Cooling capacity	Nominal (Min - Max)	kW	19,5 [5,7 - 21,0]	23,2 [6,1 - 27,0]
EER <sup>1)</sup>		W/W	3,22	3,11
<b>SEER <sup>2)</sup></b>			<b>5,3</b>	<b>4,9</b>
Pdesign		kW	19,5	23,2
Input power cooling		kW	6,06	7,46
Heating capacity	Nominal (Min - Max)	kW	22,4 [5,0 - 25,0]	28,0 [5,5 - 29,0]
COP <sup>1)</sup>		W/W	3,61	3,41
<b>SCOP <sup>2)</sup></b>			<b>3,6</b>	<b>3,6</b>
Pdesign at -10 °C		kW	17,0	20,0
Input power heating		kW	6,21	8,21
<b>Indoor unit</b>			<b>S-200PE3E5B</b>	<b>S-250PE3E5B</b>
Power source		V / ph / Hz	220 - 230 - 240 / 1/50	220 - 230 - 240 / 1/50
External static pressure at shipment (adjustable)		Pa	75 <sup>3)</sup> - 120 - 180	75 <sup>3)</sup> - 130 - 200
Air volume	Hi / Med / Lo	m <sup>3</sup> /min	72/63/53	84/72/59
Sound pressure <sup>4)</sup>	Hi / Med / Lo	dB(A)	46/44/41	47/45/42
Dimension	HxWxD	mm	486 x 1456 x 916	486 x 1456 x 916
Net weight		kg	86	88
<b>Outdoor unit</b>			<b>U-200PZH2E8</b>	<b>U-250PZH2E8</b>
Power source		V / ph / Hz	380 - 400 - 415 / 3/50	380 - 400 - 415 / 3/50
Recommended fuse		A	30	30
Air volume	Cool / Heat	m <sup>3</sup> /min	164/164	160/160
Sound pressure	Cool / Heat (Hi)	dB(A)	59/61	59/63
Sound power	Cool / Heat (Hi)	dB(A)	77/79	78/82
Dimension <sup>5)</sup>	HxWxD	mm	1500 x 980 x 370	1500 x 980 x 370
Net weight		kg	117	128
Piping connections	Liquid pipe	Inch (mm)	3/8 (9,52)	1/2 (12,70)
	Gas pipe	Inch (mm)	1 (25,40)	1 (25,40)
Pipe length range		m	5 - 90	5 - 60
Elevation difference (in/out) <sup>6)</sup>		m	30	30
Pipe length for additional gas		m	30	30
Additional gas amount		g/m	60	80
Refrigerant (R32) / CO <sub>2</sub> Eq.		kg / T	4,20/2,835	5,20/3,51
Operating range	Cool Min - Max	°C	-15 ~ +46	-15 ~ +46
	Heat Min - Max	°C	-20 ~ +24	-20 ~ +24

### Accessories

<b>CZ-RTC6</b>	<b>NEW</b> Wired remote controller (non-wireless)
<b>CZ-RTC6BL</b>	<b>NEW</b> Wired remote controller with Bluetooth®
<b>CZ-RTC5B</b>	Wired remote controller with Econavi function and datanavi
<b>CZ-RWS3 + CZ-RWRC3</b>	Infrared remote controller

### Accessories

<b>CZ-CAPWFC1</b>	Commercial Wi-Fi Adaptor
<b>PAW-GRDBSE20</b>	Outdoor base ground support for noise and vibration absorption
<b>PAW-GRDSTD40</b>	Outdoor elevation platform 400 x 900 x 400 mm
<b>CZ-CENSC1</b>	Econavi energy savings sensor

1) EER and COP calculation is based in accordance to EN14511. 2) For models below 12 kW, the SEER and SCOP is calculated based on values of EU/626/2011. For models above 12 kW, the SEER and SCOP is calculated based on values of EU/2281/2016. 3) Factory setting. 4) The sound pressure of the units shows the value measured of the position 1,5 m below the unit. The sound pressure is measured in accordance with Eurovent 6/C/006-97 specification. 5) Add 100 mm for indoor unit or 70 mm for outdoor unit for piping port. 6) When installing the outdoor unit at a higher position than the indoor unit. \* No filter included.



INTERNET CONTROL: Optional.

Compatible with all Panasonic connectivity solutions. For detailed information go to the Control Systems section.

# PRO-HT Tank Series for PACi

Enjoy an efficient DHW / heating and cooling tank.  
Panasonic commercial PRO-HT Tank solutions meet all needs  
of your hot water applications providing 65 °C water.



## PRO-HT Tank DHW

PRO-HT Tank			PAW-VP750LDHW	PAW-VP1000LDHW
Outdoor Unit			U-250PE2E8A	U-250PE2E8A
Volume (net)	L		726	933
Height	H x Ø	mm	1855 x 990	2210 x 990
Connections to the water supply network			1 1/4"	1 1/4"
Net weight / with water	kg		179/929	235/1167
Nominal electrical power	W		8270	8270
Reference tapping cycle			2XL	2XL
Energy consumption by chosen cycle A7 / W10-55	kWh		6,0	6,30
Energy consumption by chosen cycle A15 / W10-55	kWh		4,9	5,12
COP DHW (A7 / W10-55) EN 16147 <sup>1)</sup>			4,10	3,89
COP DHW (A15 / W10-55) EN 16147 <sup>2)</sup>			5,00	4,79
<b>Energy Efficiency Class (from A+ to F) <sup>3)</sup></b>			<b>A+</b>	<b>A+</b>
Standby input power according to EN16147	W		77,00	80,00
Sound pressure on 1m	dB(A)		57	57
Quantity of refrigerant	g		6400	6400
Operating range - air temperature	°C		-20 ~ +35	-20 ~ +35
Stainless steel 316L tank			Yes	Yes
Average insulation thickness	mm		100	100
Heat exchanger connection for inlet / outlet	Inch (mm)		1/2 (12,70) / 3/4 (19,05)	1/2 (12,70) / 3/4 (19,05)
Maximum power consumption without heater	W		10000	10000
Maximum power consumption with heater	W		16000	16000
Number of electrical heaters x power	W		1 x 6000	1 x 6000
Voltage / Frequency	V / Hz		400 / 50	400 / 50
Electric protection	A		16	16
Moisture protection			IP24	IP24
Heating with heat pump	Min / Max	°C	65	65
Heating with electrical heater	Max	°C	85	85
Refrigerant (R410A) / CO <sub>2</sub> Eq.	kg / T		6,4 / 13,363	6,4 / 13,363

## Accessories

**PAW-VP-RTC5B-PAC** Tank controller for PACi system

1) Heating of sanitary water up to 55°C with inlet air temperature at 7 °C, humidity at 89 % and inlet water temperature at 10 °C. According to EN16147. 2) Heating of sanitary water up to 55°C with inlet air temperature at 15 °C, humidity at 74 % and inlet water temperature at 10 °C. According to EN16147. 3) Scale from A+ to F following [COMMISSION DELEGATED REGULATION (EU) No. 812/2013].

This product is designed to comply with the European Water Quality Directive 98/83/EC amended by 2015/1787/EU. The lifespan of the product is not guaranteed in the case of the use of groundwater, such as spring water or well water, the use of tap water when salt or other impurities are contained, nor in areas of acidic water quality. Maintenance and warranty costs related to these cases are the customer's responsibility.

\* When connected as pressurised, safety valve is mandatory.



## Solution example DHW tank 1000 L + PACi

- Ideal for small hotels and high-end residential
- Hot water temperature up to 65 °C

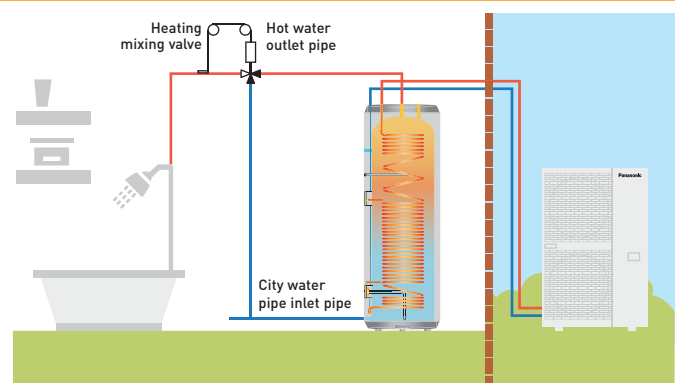



# PRO-HT TANK

## PRO-HT Tank heating and cooling

PRO-HT Tank			PAW-VP380L
Cooling capacity at 35 °C, water outlet 7 °C		kW	12,80
Heating capacity		kW	25,00
Heating capacity at +7 °C, heating water temperature at 45 °C		kW	23,00
COP at +7 °C with heating water temperature at 45 °C		W/W	3,26
<b>Heating Energy Efficiency class at 35 °C (from A+++ to D)</b>			<b>A+++</b>
$\eta_{sh}$ (LOT1) <sup>1)</sup>		%	193
Dimension	H x Ø	mm	1820x690
Shipping weight		kg	99
Water pipe connector			1 1/4"
Heating water flow ( $\Delta T=5$ K, 35 °C)		m <sup>3</sup> /h	3,9
<b>Outdoor Unit</b>			<b>U-200PZH2E8</b>
Sound pressure		dB(A)	57
Dimension	H x W x D	mm	1500 x 980 x 370
Net weight		kg	117
Piping connections	Liquid pipe	Inch (mm)	1/2 (12,07)
	Gas pipe	Inch (mm)	3/4 (19,05)
Refrigerant (R32) / CO <sub>2</sub> Eq.		kg	4,20 (1,0kg additional gas charge on site)
Pipe length range <sup>2)</sup>		m	30
Elevation difference (in/out)		m	30 (OD above) 30 (OD below)
Pipe length for nominal capacity		m	7,5
Pipe length for additional gas		m	> 7,5
Additional gas amount		g/m	Refer to manual
Operation range - Outdoor ambient	Heat / Cool	°C	-20 ~ +24 / -15 ~ +46
Water outlet	Heat / Cool	°C	25 ~ 45 / 5 ~ 15

### Accessories

**PAW-VP-RTC5B-PAC** Tank controller for PACi system

### Accessories

**PAW-IU29/39** Additional heater

1) Seasonal space cooling/heating energy efficiency following COMMISSION REGULATION (EU) 811/2013. 2) The pipe length range is between indoor and outdoor, but does not include additional length for coil.

This product is designed to comply with the European Water Quality Directive 98/83/EC amended by 2015/1787/EU. The lifespan of the product is not guaranteed in the case of the use of groundwater, such as spring water or well water, the use of tap water when salt or other impurities are contained, nor in areas of acidic water quality. Maintenance and warranty costs related to these cases are the customer's responsibility.

Performance calculation in agreement with Eurovent. Sound pressure measured at 1 m from the outdoor unit and at 1,5 m height.

\* Flow switch and water filter are not equipped.



## Heating and cooling tank 380L + PACi 20,0 kW

- Ideal offer for small offices
- Cost saving solution with simple waterborne heating and cooling
- Hot water up to 45 °C

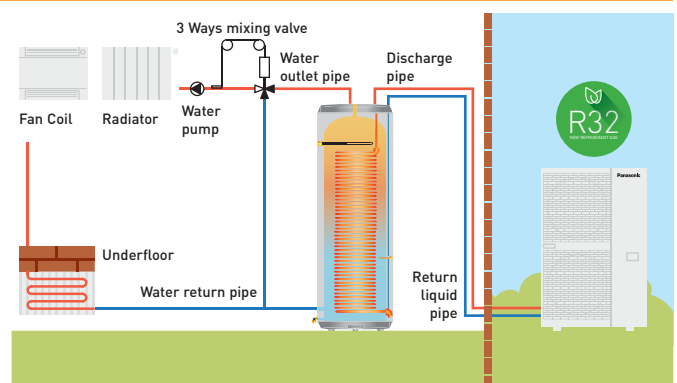

# PACi with Water Heat Exchanger

## - R32 refrigerant

Panasonic introduces highly-efficient Water Heat Exchanger for PACi Series. This ground-breaking product gives further possibilities of PACi solutions by adding hydronic options.

### WATER OUTLET TEMPERATURE

Cooling: 5 ~ 15 °C

Heating: 35 ~ 50 °C



### 1 Cost Saving Solution

- A+++ Energy efficiency class (scale from A+++ to D)
- Cost effective water projects thanks to lower cost for PACi compared to VRF

### 2 Space Saving & Flexible Positioning

- 2 installation possibilities (Wall-mounted / Floor-standing)
- Compact, lightweight unit design, only 27kg

### 3 Easy Installation, Maintenance

- Quick mounting process
- Flow switch kit is included as a standard
- Direct access to electrical box

#### System example.

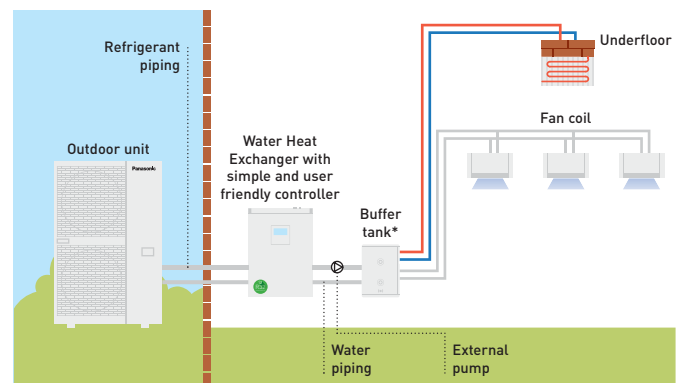

\* Minimum buffer tank volume: 10 L/kW. \*\* Diagram is for illustrative purpose only.

#### Space saving & Flexible positioning

##### Compact and light unit.

- Only 205 mm depth fits within a limited space
- Lightweight design at only 27kg, makes it easy to maneuver and position
- Maximum total refrigerant piping length: 90 m\*

\* 90 m for PAW-200W5APAC.



#### 2 installation options.

- Wall-mounted and Floor-standing installation options are available. Free-up floor space by using the Wall-mounted installation
  - Quick mounting process with its lightweight compact design
- Make fixing holes → Fix 2 screws → Hang the unit → Finish

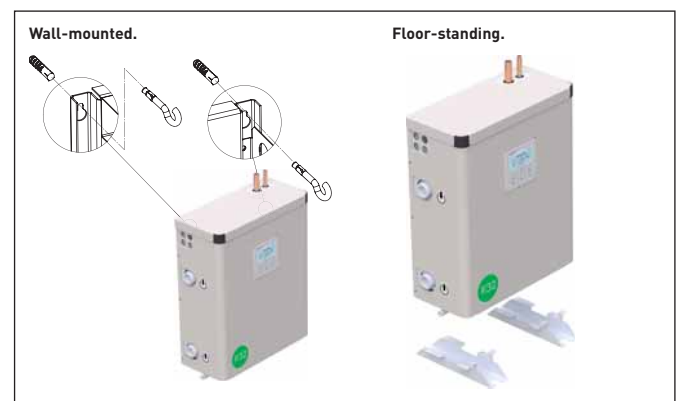



### PACi with Water Heat Exchanger for chilled and hot water production

			PAW-200W5APAC	PAW-250W5APAC
Cooling capacity <sup>1)</sup>	kW		20,00	25,00
EER <sup>1)</sup>	W/W		3,03	2,89
Heating capacity <sup>2)</sup>	kW		23,00	28,00
COP <sup>2)</sup>	W/W		2,98	2,95
$\eta_{sh}$ (LOT1) <sup>3)</sup>	%		178	178
<b>Energy efficiency class (Scale A+++ to D) <sup>4)</sup></b>			<b>A+++</b>	<b>A+++</b>
Dimension	HxWxD	mm	550 x 455 x 205	550 x 455 x 205
Net weight		kg	27	27
Water pipe connector		Inch	Male Thread 1 ¼	Male Thread 1 ¼
Cooling water flow ( $\Delta T=5$ K, 35 °C)		m <sup>3</sup> /h	3,45	4,30
Heating water flow ( $\Delta T=5$ K, 35 °C)		m <sup>3</sup> /h	4,15	4,85
Flow switch			Included	Included
Water filter			Included	Included
<b>Outdoor unit</b>			<b>U-200PZH2E8</b>	<b>U-250PZH2E8</b>
Sound pressure	Cool / Heat (Hi)	dB(A)	59/61	59/63
Dimension	HxWxD	mm	1500 x 980 x 370	1500 x 980 x 370
Net weight		kg	117	128
Piping connections	Liquid pipe	Inch (mm)	3/8 (9,52)	1/2 (12,70)
	Gas pipe	Inch (mm)	1 (25,40)	1 (25,40)
Pipe length range		m	5 ~ 90	5 ~ 60
Elevation difference (in/out)		m	30	30
Pipe length for additional gas		m	30	30
Additional gas amount		g/m	60	80
Water outlet temperature range	Cool Min ~ Max	°C	+5 ~ +15	+5 ~ +15
	Heat Min ~ Max	°C	+35 ~ +50	+35 ~ +50
Operating range	Cool Min ~ Max	°C	-15 ~ +46	-15 ~ +46
	Heat Min ~ Max	°C	-20 ~ +24	-20 ~ +24

1) Data refers to 7 °C leaving chilled water temperature and 35 °C ambient air temperature, according to EN14511 standard. 2) Data refers to 45 °C leaving warm water temperature and 7 °C ambient air temperature according to EN14511 standard. 3) Following COMMISSION REGULATION (EU) No 813/2013 for low-temperature heat pumps. 4) Following COMMISSION REGULATION (EU) No 811/2013 for low-temperature heat pumps. Scale from A+++ to D.



**PACi Water Heat Exchanger (WHE) is ideal solution for small retails and offices.**  
**This is the first PACi connected WHE system.**  
**The investment costs can be amortised in a short period.**

#### Quick installation with pre-assembled flow switch

The flow switches come pre-assembled with pipe fittings for ease of installation.

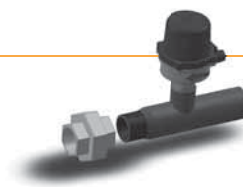

# PACi Single, Twin, Triple and Double-Twin System



**1 PACi Standard from 7,1 to 14,0 kW**  
Up to 2 indoor units connectable on the same outdoor. Panasonic's PACi units can be installed as single and twin systems. The indoor units can be combined following the selection table. The operation will always be simultaneous. All the indoor units will work with the same settings.

**2 PACi Elite from 7,1 to 14,0 kW**  
Up to 4 indoor units can be connected to the same outdoor unit. Panasonic's PACi units 7,1, 10,0, 12,0 and 14,0 can be installed as twin, triple and double-twin systems. The indoor units can be combined as per the selection table. The operation will always be simultaneous. All the indoor units will work with the same settings.

**3 Big PACi Elite from 20,0 to 25,0 kW**  
Up to 4 indoor units can be connected to the same outdoor unit. Panasonic's PACi units 20,0 and 25,0 can be installed as twin, triple and double-twin systems. The indoor units can be combined as per the selection table. The operation will always be simultaneous. All the indoor units will work with the same settings.



With this system, a single outdoor unit can split capacity for up to 4 indoor areas simultaneously. This makes the system particularly apt for common areas. It reduces noise concentration and enables the same temperature to be reached around the room. A mix of indoor units can be installed (Wall-mounted, Cassette, Hide Away, Ceiling) in one system.

**PACi Standard from 7,1 to 14,0 kW Single/Simultaneous operation system combinations • R32 refrigerant**

Indoor	Outdoor			
	7,1 kW	10,0 kW	12,5 kW	14,0 kW
3,6 kW				
5,0 kW		Twin U-100 S-50 S-50		
6,0 kW			Twin U-125 S-60 S-60	
7,1 kW	Single 2) U-71 S-71			Twin U-140 S-71 S-71
10,0 kW		Single 2) U-100 S-100		
12,5 kW			Single 2) U-125 S-125	
14,0 kW				Single 2) U-140 S-140

**PACi Elite from 7,1 to 14,0 kW Single/Simultaneous operation system combinations • R32 refrigerant**

Indoor	Outdoor			
	7,1 kW	10,0 kW	12,5 kW	14,0 kW
3,6 kW	Twin U-71 S-36 S-36	Triple U-100 S-36 S-36 S-36	Double-Twin U-125 S-36 S-36 S-36 S-36	
4,5 kW			Triple U-125 S-45 S-45 S-45	
5,0 kW		Twin U-100 S-50 S-50		Triple U-140 S-50 S-50 S-50
6,0 kW			Twin U-125 S-60 S-60	
7,1 kW	Single 2) U-71 S-71			Twin U-140 S-71 S-71
10,0 kW		Single 2) U-100 S-100		
12,5 kW			Single 2) U-125 S-125	
14,0 kW				Single 2) U-140 S-140

**PACi Elite from 20,0 to 25,0 kW Single/Simultaneous operation system combinations • R32 refrigerant**

Indoor	Outdoor	
	20,0 kW	25,0 kW
5,0 kW	Double-Twin U-200 S-50 S-50 S-50 S-50	
6,0 kW		Double-Twin U-250 S-60 S-60 S-60 S-60
7,1 kW	Triple U-200 S-71 S-71 S-71	
10,0 kW	Twin U-200 S-100 S-100	
12,5 kW		Twin U-250 S-125 S-125
20,0 kW	Single 2) U-200 S-200	
25,0 kW		Single 2) U-250 S-250

1) Available for only PZ2 (R32) model with limitations of main pipe and branch pipe. Please contact an authorized Panasonic dealer. 2) PACi 1x1 Kit solution.



PACi Elite Outdoor units • R32 refrigerant			7,1 kW	10,0 kW	12,5 kW	14,0 kW	20,0 kW	25,0 kW
<b>Outdoor unit Single Phase</b>			<b>U-71PZH2E5</b>	<b>U-100PZH2E5</b>	<b>U-125PZH2E5</b>	<b>U-140PZH2E5</b>	—	—
<b>Outdoor unit Three Phase</b>			<b>U-71PZH2E8</b>	<b>U-100PZH2E8</b>	<b>U-125PZH2E8</b>	<b>U-140PZH2E8</b>	<b>U-200PZH2E8</b>	<b>U-250PZH2E8</b>
Cooling capacity	Nominal (Min - Max)	kW	7,1 [2,2 - 9,0]	10,0 [3,1 - 12,5]	12,5 [3,2 - 14,0]	14,0 [3,3 - 16,0]	20,0 [5,7 - 22,4]	25,0 [6,1 - 28,0]
Heating capacity	Nominal (Min - Max)	kW	8,0 [2,0 - 9,0]	11,2 [3,1 - 14,0]	14,0 [3,2 - 16,0]	16,0 [3,3 - 18,0]	22,4 [5,0 - 25,0]	28,0 [5,5 - 31,5]
Power source	Single Phase	V	220 - 230 - 240	220 - 230 - 240	220 - 230 - 240	220 - 230 - 240	—	—
	Three Phase	V	380 - 400 - 415	380 - 400 - 415	380 - 400 - 415	380 - 400 - 415	380 - 400 - 415	380 - 400 - 415
Connection indoor / outdoor		mm <sup>2</sup>	2 x 1,5 or 2,5	2 x 1,5 or 2,5	2 x 1,5 or 2,5	2 x 1,5 or 2,5	—	—
Air volume	Cool / Heat	m <sup>3</sup> /min	61/60	118/108	125/122	129/116	164/164	160/160
Sound pressure	Cool / Heat (Hi)	dB(A)	48/50	52/52	53/53	54/54	59/61	59/63
Sound power	Cool / Heat (Hi)	dB(A)	65/67	69/69	70/70	71/71	77/79	78/82
Dimension	HxWxD	mm	996 x 940 x 340	1416 x 940 x 340	1416 x 940 x 340	1416 x 940 x 340	1500 x 980 x 370	1500 x 980 x 370
Net weight		kg	68	99	99	99	117	128
Piping connections	Liquid pipe	Inch (mm)	3/8 [9,52]	3/8 [9,52]	3/8 [9,52]	3/8 [9,52]	3/8 [9,52]	1/2 [12,70]
	Gas pipe	Inch (mm)	5/8 [15,88]	5/8 [15,88]	5/8 [15,88]	5/8 [15,88]	1 [25,40]	1 [25,40]
Pipe length range	Min ~ Max	m	5 ~ 50	5 ~ 85	5 ~ 85	5 ~ 85	5 ~ 80	5 ~ 60
Elevation difference (in/out)	Max	m	30	30	30	30	30	30
Pipe length for additional gas		m	30	30	30	30	30	30
Additional gas amount		g/m	45	45	45	45	60	80
Refrigerant (R32) / CO <sub>2</sub> Eq.		kg / T	1,95 / 1,316	3,05 / 2,059	3,05 / 2,059	3,05 / 2,059	4,20 / 2,835	5,20 / 3,51
Operating range	Cool Min ~ Max	°C	-15 ~ +46	-20 <sup>1)</sup> ~ +46	-20 <sup>1)</sup> ~ +46	-20 <sup>1)</sup> ~ +46	-15 ~ +46	-15 ~ +46
	Heat Min ~ Max	°C	-20 ~ +24	-20 ~ +24	-20 ~ +24	-20 ~ +24	-20 ~ +24	-20 ~ +24

1) For models 100 ~ 140PZH2E5(8), it is possible to operate the lowest -20 °C in the computer rooms with the piping length of 30 m or less.



PACi Standard Outdoor units • R32 refrigerant			7,1 kW	10,0 kW	12,5 kW	14,0 kW
<b>Outdoor unit Single Phase</b>			<b>U-71PZ2E5</b>	<b>U-100PZ2E5</b>	<b>U-125PZ2E5</b>	<b>U-140PZ2E5</b>
<b>Outdoor unit Three Phase</b>			—	<b>U-100PZ2E8</b>	<b>U-125PZ2E8</b>	<b>U-140PZ2E8</b>
Cooling capacity	Nominal (Min - Max)	kW	7,1	10,0 [3,0 - 11,5]	12,5 [3,2 - 13,5]	14,0 [3,3 - 15,0]
Heating capacity	Nominal (Min - Max)	kW	7,1	10,0 [3,0 - 14,0]	12,5 [3,3 - 15,0]	14,0 [3,4 - 16,0]
Power source	Single Phase	V	220 - 230 - 240	220 - 230 - 240	220 - 230 - 240	220 - 230 - 240
	Three Phase	V	—	380 - 400 - 415	380 - 400 - 415	380 - 400 - 415
Connection indoor / outdoor		mm <sup>2</sup>	2 x 1,5 or 2,5	2 x 1,5 or 2,5	2 x 1,5 or 2,5	2 x 1,5 or 2,5
Air volume	Cool / Heat	m <sup>3</sup> /min	50/45	76/70	86/78	89/83
Sound pressure	Cool / Heat (Hi)	dB(A)	49/49	52/52	55/55	56/56
Sound power	Cool / Heat (Hi)	dB(A)	69/69	70/70	73/73	74/74
Dimension	HxWxD	mm	695 x 875 x 320	996 x 980 x 370	996 x 980 x 370	996 x 980 x 370
Net weight		kg	44	90	94	94
Piping connections	Liquid pipe	Inch (mm)	3/8 [9,52]	3/8 [9,52]	3/8 [9,52]	3/8 [9,52]
	Gas pipe	Inch (mm)	5/8 [15,88]	5/8 [15,88]	5/8 [15,88]	5/8 [15,88]
Pipe length range	Min ~ Max	m	3 ~ 40	5 ~ 50	5 ~ 50	5 ~ 50
Elevation difference (in/out)	Max	m	30	30	30	30
Pipe length for additional gas		m	30	30	30	30
Additional gas amount		g/m	35	45	45	45
Refrigerant (R32) / CO <sub>2</sub> Eq.		kg / T	1,45 / 0,979	2,60 / 1,755	2,98 / 2,0115	2,98 / 2,0115
Operating range	Cool Min ~ Max	°C	-10 ~ +43	-10 ~ +43	-10 ~ +43	-10 ~ +43
	Heat Min ~ Max	°C	-15 ~ +24	-15 ~ +24	-15 ~ +24	-15 ~ +24



Wall-mounted	Indoor	Cooling capacity	Heating capacity	Dimension	Sound pressure	Air volume
				HxWxD	Hi / Med / Lo	Hi / Med / Lo
				mm	dB(A)	m <sup>3</sup> /min
3,6 kW	S-36PK2E5B	3,6	4,2	302 x 1120 x 236	35/31/27	11,00/9,50/7,50
4,5 kW	S-45PK2E5B	4,5	5,2	302 x 1120 x 236	38/34/30	12,00/10,50/8,50
5,0 kW	S-50PK2E5B	5,0	5,6	302 x 1120 x 236	40/36/32	14,00/12,00/10,50
6,0 kW	S-60PK2E5B	6,0	7,0	302 x 1120 x 236	47/44/40	18,00/14,50/11,50
7,1 kW	S-71PK2E5B	7,1	8,0	302 x 1120 x 236	47/44/40	18,00/14,50/11,50
10,0 kW	S-100PK2E5B	10,0	11,2	302 x 1120 x 236	47/44/40	19,00/16,50/13,00

4 Way 60x60 Cassette	Indoor (Panels CZ-KPY3AW / CZ-KPY3BW)	Cooling capacity	Heating capacity	Dimension: Indoor / CZ-KPY3AW / CZ-KPY3BW		Sound pressure	Air volume
				HxWxD		Hi / Med / Lo	Hi / Lo
				mm		dB(A)	m <sup>3</sup> /min
3,6 kW	S-36PY2E5B	3,6	4,2	288 x 583 x 583 / 31 x 700 x 700 / 31 x 625 x 625		36/32/26	9,70/9,90
4,5 kW	S-45PY2E5B	4,5	5,2	288 x 583 x 583 / 31 x 700 x 700 / 31 x 625 x 625		38/34/28	10,00/10,30
5,0 kW	S-50PY2E5B	5,0	5,6	288 x 583 x 583 / 31 x 700 x 700 / 31 x 625 x 625		40/37/33	11,10/11,10

4 Way 90x90 Cassette	Indoor (Panels CZ-KPU3W / CZ-KPU3AW)	Cooling capacity	Heating capacity	Dimension Indoor	Dimension Panel	Sound pressure	Air volume
				HxWxD	HxWxD	Hi / Med / Lo	Hi / Med / Lo
				mm	mm	dB(A)	m <sup>3</sup> /min
3,6 kW	S-36PU2E5B	3,6	4,2	256 x 840 x 840	33,5 x 950 x 950	30/28/27	14,50/13,00/11,50
4,5 kW	S-45PU2E5B	4,5	5,2	256 x 840 x 840	33,5 x 950 x 950	31/28/27	15,50/13,00/11,50
5,0 kW	S-50PU2E5B	5,0	5,6	256 x 840 x 840	33,5 x 950 x 950	32/29/27	16,50/13,50/11,50
6,0 kW	S-60PU2E5B	6,0	7,0	256 x 840 x 840	33,5 x 950 x 950	38/31/28	21,00/16,00/13,00
7,1 kW	S-71PU2E5B	7,1	8,0	256 x 840 x 840	33,5 x 950 x 950	37/31/28	22,00/16,00/13,00
10,0 kW	S-100PU2E5B	10,0	11,2	319 x 840 x 840	33,5 x 950 x 950	45/38/32	36,00/26,00/18,00
12,5 kW	S-125PU2E5B	12,5	14,0	319 x 840 x 840	33,5 x 950 x 950	46/39/33	37,00/27,00/19,00
14,0 kW	S-140PU2E5B	14,0	14,0	319 x 840 x 840	33,5 x 950 x 950	47/40/34	38,00/29,00/20,00

Ceiling	Indoor	Cooling capacity	Heating capacity	Dimension	Sound pressure	Air volume
				HxWxD	Hi / Med / Lo	Hi / Med / Lo
				mm	dB(A)	m <sup>3</sup> /min
3,6 kW	S-36PT2E5B	3,6	4,2	235 x 960 x 690	35/32/30	14,00/12,00/10,50
4,5 kW	S-45PT2E5B	4,5	5,2	235 x 960 x 690	38/33/30	15,00/12,50/10,50
5,0 kW	S-50PT2E5B	5,0	5,6	235 x 960 x 690	38/33/30	15,00/12,50/10,50
6,0 kW	S-60PT2E5B	6,0	7,0	235 x 1275 x 690	39/36/33	20,00/17,00/14,50
7,1 kW	S-71PT2E5B	7,1	8,0	235 x 1275 x 690	39/36/33	21,00/18,00/15,50
10,0 kW	S-100PT2E5B	10,0	11,2	235 x 1590 x 690	42/38/35	30,00/25,00/23,00
12,5 kW	S-125PT2E5B	12,5	14,0	235 x 1590 x 690	45/40/37	34,00/28,00/24,00
14,0 kW	S-140PT2E5B	14,0	14,0	235 x 1590 x 690	47/41/37	35,00/29,00/25,00

High Static Pressure Hide Away	Indoor	Cooling capacity	Heating capacity	Dimension	External static pressure	Sound pressure	Air volume
				HxWxD	Hi / Med / Lo	Hi / Med / Lo	Hi / Med / Lo
				mm	Pa	dB(A)	m <sup>3</sup> /min
3,6 kW	S-36PF1E5B	3,6	4,2	290 x 800 x 700	150/70/10	33/29/25	14,00/13,00/10,00
4,5 kW	S-45PF1E5B	4,5	5,2	290 x 800 x 700	150/70/10	34/30/26	14,00/13,00/10,00
5,0 kW	S-50PF1E5B	5,0	5,6	290 x 800 x 700	150/70/10	34/30/26	16,00/15,00/12,00
6,0 kW	S-60PF1E5B	6,0	7,0	290 x 1000 x 700	150/70/10	35/32/26	21,00/19,00/15,00
7,1 kW	S-71PF1E5B	7,1	8,0	290 x 1000 x 700	150/70/10	35/32/26	21,00/19,00/15,00
10,0 kW	S-100PF1E5B	10,0	11,2	290 x 1400 x 700	150/100/10	38/34/31	32,00/26,00/21,00
12,5 kW	S-125PF1E5B	12,5	14,0	290 x 1400 x 700	150/100/10	39/35/32	34,00/29,00/23,00
14,0 kW	S-140PF1E5B	14,0	14,0	290 x 1400 x 700	150/100/10	40/36/33	36,00/32,00/25,00

Low Static Pressure Hide Away	Indoor	Cooling capacity	Heating capacity	Dimension	External static pressure	Sound pressure	Air volume
				HxWxD	Hi / Med / Lo	Hi / Med / Lo	Hi / Med / Lo
				mm	Pa	dB(A)	m <sup>3</sup> /min
3,6 kW	S-36PN1E5B	3,6	4,2	250 x 780 x 650	80/50/10	40/38/35	14,00/12,00/10,00
4,5 kW	S-45PN1E5B	4,5	5,2	250 x 780 x 650	80/50/10	41/39/35	16,00/13,00/11,00
5,0 kW	S-50PN1E5B	5,0	5,6	250 x 780 x 650	80/50/10	41/39/35	16,00/13,00/11,00
6,0 kW	S-60PN1E5B	6,0	7,0	250 x 1000 x 650	80/50/10	43/41/36	22,00/20,00/16,00
7,1 kW	S-71PN1E5B	7,1	8,0	250 x 1000 x 650	80/50/10	43/41/36	22,00/20,00/16,00
10,0 kW	S-100PN1E5B	10,0	11,2	250 x 1200 x 650	80/50/10	44/42/37	36,00/33,00/26,00
12,5 kW	S-125PN1E5B	12,5	14,0	250 x 1200 x 650	80/50/10	46/44/39	38,00/35,00/28,00
14,0 kW	S-140PN1E5B	14,0	14,0	250 x 1200 x 650	80/50/10	46/44/39	40,00/37,00/30,00

# Datanavi

Datanavi, a new way to connect.  
Simple and easy support tool with your smartphone.

**FAST AND INTUITIVE**

**EASY ACCESS TO MANUAL DATABASE**

**ACCURATE SERVICE DATA ON YOUR SMARTPHONE**



## Overview of datanavi system

Just holding up your smartphone to the LED display on a remote controller (CZ-RTC5B) to receive useful AC system information super fast by Panasonic Light ID Technology. Datanavi also connects to Panasonic Cloud Server for the quick view of manuals, saving data received by Light ID.



## Key Functions

- Scan and Save AC system info
- Easy access to manual database
- Commissioning, F-Gas check data history

## User / Administrator (person in charge of AC) functions

- **Fast and intuitive.** Regular operation data, Energy consumption data display
- **Easy access to data base.** Getting manuals related on demand
- **No idea what to do when an error happens?** You can share error information and contact service easily

### Regular operation



### Energy management



### Malfunction notice

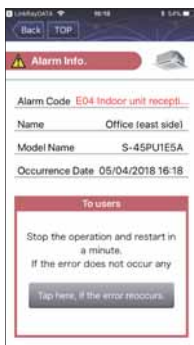

### Operating manual



### Test run info



### Service data



\* User interface image may be updated without notification.

## Installer / Service company functions

- **Getting technical data depends on your need.** Service manual, Q & A list, Test run information
- **Accurate error information**

Simple F-gas regulation check list, Repair speed check list.

Download free Apps, try datanavi!  
2 free Apps are necessary to use datanavi.



# Remote controller with Econavi and datanavi

Easy to use, attractive, clear design, with new demand control functions and energy consumption display! This useful feature makes this remote controller unique!



## Key Functions

- Easy setup of the timer and settings of the indoor unit
- Energy consumption display
- Limitation of the energy consumption (Demand control) by timer

## Backup control by using CZ-RTC5B

Group wiring of 2 systems of PACi can do auto individual control: Rotation operation, Backup operation and Support operation (failure substitution).

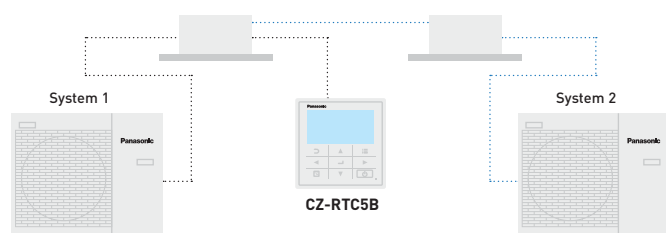

## Basic function (operation display and indication)

All functions are easily available on the remote controller.

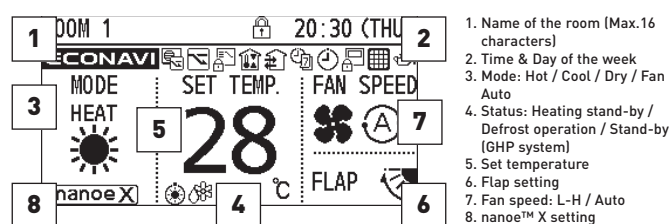

## Functions available on the CZ-RTC5B

Control item	Controllability	Indoor units	
		PACi	VRF
Basic Operation	Operation, Mode, Temperature setting, Air flow volume, Air flow direction	✓	✓
	Time display	✓	✓
Timer function	Easy ON/OFF timer	✓	✓
	Weekly Program timer	✓	✓
	Outing function	✓	✓
Energy saving	Temperature auto return	✓	✓
	Temperature setting range limitation	✓	✓
	OFF remind	✓	✓
	Energy saving mode	✓	✓
	Schedule demand control	✓	✓
	Energy monitoring - R32	✓	—

Control item	Controllability	Indoor units	
		PACi	VRF
Maintenance	System failure information	✓	✓
	Service contact registration	✓	✓
	Filter sign (rest time display) & Reset	✓	✓
	Auto-address, Test run	✓	✓
	Sensor value monitor	✓	✓
	Simple / Detail setting mode	✓	✓
Others	Key lock	✓	✓
	Ventilation fan control	✓	✓
	Display contrast adjustment	✓	✓
	Remote controller sensor	✓	✓
	Quiet operation mode	✓	—
Prohibit setting control from Central controller	✓	✓	

All specifications subject to change without notice.

## Panasonic Ventilation Solutions

Increase the efficiency of an installation with the use of AHU ventilation and a wide range of air curtains.





## Air Curtain with DX Coil

Outdoor unit			7,1 kW	10,0 kW	14,0 kW	20,0 kW
Air outlet height 2,7 m			PAW-10PAIRC-LS	PAW-15PAIRC-LS	PAW-20PAIRC-LS	PAW-25PAIRC-LS
Air volume	High	m <sup>3</sup> /h	1800	2700	3600	4500
Cooling capacity <sup>1)</sup>	Max	kW	6,1	9,7	13,0	17,0
Heating capacity <sup>2)</sup>	Max	kW	7,9	12,0	15,0	19,0
Heat Exchanger	Volume	L	1,67	2,85	3,94	5,03
Piping connections	Liquid pipe / Gas pipe	Inch (mm)	3/8 (9,52) / 5/8 (15,88)	3/8 (9,52) / 3/4 (19,05)	3/8 (9,52) / 7/8 (22,22)	3/8 (9,52) / 7/8 (22,22)
Electric consumption fan	230 V / 50Hz	kW	0,30	0,50	0,60	0,80
Fan type			EC	EC	EC	EC
Current	230 V / 50Hz	A	2,10	3,10	4,10	5,10
Sound pressure <sup>3)</sup>	Max	dB(A)	65	66	67	69
Dimension <sup>4)</sup>	HxWxD	mm	260(+140)x1000x460	260(+140)x1500x460	260(+140)x2000x460	260(+140)x2500x460
Weight		kg	50	65	80	95
Door width		m	1,0	1,5	2,0	2,5
Refrigerant			R32/R410A	R32/R410A	R32/R410A	R32/R410A

Outdoor unit			10,0 kW	14,0 kW	20,0 kW	25,0 kW
Air outlet height 3,0 m			PAW-10PAIRC-HS	PAW-15PAIRC-HS	PAW-20PAIRC-HS	PAW-25PAIRC-HS
Air volume	High	m <sup>3</sup> /h	2700	3600	5400	6300
Cooling capacity <sup>1)</sup>	Max	kW	9,1	13,0	19,5	23,7
Heating capacity <sup>2)</sup>	Max	kW	11,8	15,8	23,6	27,6
Heat Exchanger	Volume	L	1,67	2,85	3,94	5,12
Piping connections	Liquid pipe / Gas pipe	Inch (mm)	3/8 (9,52) / 5/8 (15,88)	3/8 (9,52) / 3/4 (19,05)	3/8 (9,52) / 7/8 (22,22)	3/8 (9,52) / 7/8 (22,22)
Electric consumption fan	230 V / 50Hz	kW	0,75	1,00	1,50	1,75
Fan type			EC	EC	EC	EC
Current	230 V / 50Hz	A	4,10	5,50	8,20	9,60
Sound pressure <sup>3)</sup>	Max	dB(A)	66	67	68	68
Dimension <sup>4)</sup>	HxWxD	mm	260(+140)x1000x460	260(+140)x1500x460	260(+140)x2000x460	260(+140)x2500x460
Weight		kg	55	65	85	110
Door width		m	1,0	1,5	2,0	2,5
Refrigerant			R32/R410A	R32/R410A	R32/R410A	R32/R410A

### Accessories

**PAW-AIR1-DP** Optional drain pump

1) Cooling capacity DX Coil, air temperature in/out +27/+18 °C, R32 and R410. 2) Heating capacity condenser, air temperature in/out +20/+33 °C, R32 and R410. In the case of lower outdoor temperatures, an outdoor model with higher capacity may be necessary. 3) Measured in distance up to 5,0 m, direction factor 2, absorbing surfaces 200 m<sup>2</sup>, Min / Max air volume. 4) 140 mm is the height of an electrical box if it is installed on the top.



## Electric Air Curtain

			FY-3009U1	FY-3012U1	FY-3015U1
Width		mm	900	1200	1500
Voltage		V	220	220	220
Air volume	Hi / Lo	m <sup>3</sup> /h	1100/920	1400/1270	2000/1800
Consumption	Hi / Lo	W	76/70	94/85	131/110
Current	Hi / Lo	A	0,35/0,32	0,43/0,40	0,59/0,50
Air speed	Hi / Lo	m/s	10,50/8,50	9,50/8,00	10,50/9,50
Sound pressure		dB(A)	48,5/45,0	48,5/44,5	51,5/48,0
Dimension / Net weight	HxWxD	mm / kg	900x231,5x212/12,0	1200x231,5x212/14,5	1500x231,5x212/18,0

# With an AHU kit, the PACi/ECOi outdoor unit is connected to air handling units of 3,6-189 kW



With the new AHU kit it is easy to connect Panasonic PACi and VRF outdoor units to air handling units with a refrigeration circuit without water or glycol. The flexible connectivity options mean that a Panasonic AHU kit can easily integrate and interact with the overall control system. Applications: Hotels, offices, computer server rooms or other spacious buildings where there is a need to control air quality, humidity and fresh air.

### 3 types of AHU Kit: Deluxe, Medium and Light

Model code	IP 65	0-10 V demand control*	Outdoor temperature shift compensation. Cold draft prevention
<b>PACi</b>	PAW-280PAH2	Yes	Yes
	PAW-280PAH2M	Yes	No
	PAW-280PAH2L	Yes	No
<b>VRF</b>	PAW-160MAH2 / PAW-280MAH2 / PAW-560MAH2	Yes	Yes
	PAW-160MAH2M / PAW-280MAH2M / PAW-560MAH2M	Yes	No
	PAW-160MAH2L / PAW-280MAH2L / PAW-560MAH2L	Yes	No

\* With CZ-CAPBC2.

### Panasonic AHU kit, 3,6-189 kW connected to PACi or ECOi outdoor unit

The Air Handling Unit Kit has been developed to better meet customer demand: IP 65 Box in order to be installed outside, 0-10V demand control\* and easy control by BMS

\* Only available with PACi Elite, from 3,6 kW to 25,0 kW.

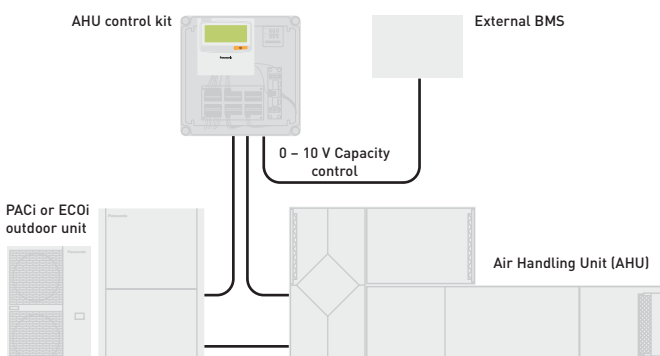

Demand control on the outdoor unit managed by external 0-10 V signal.

### Main components of mechanical ventilation systems

The main components of a mechanical ventilation system are the following: Air Handling Unit (AHU), air ducts and air distribution elements.

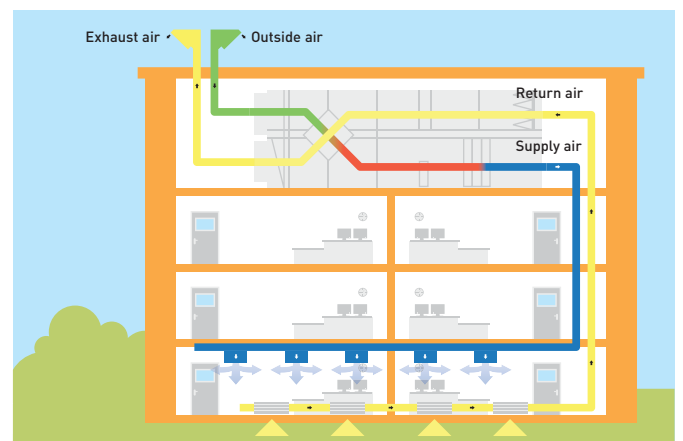



**PAW-280PAH2M // PAW-160MAH2M // PAW-280MAH2M // PAW-560MAH2M**

- The system is controlled by the intake air (or return air from the room) temperature as well as by the control function: Automatic/Cooling/Heating
- The temperature of the outgoing air is also checked, to prevent excessively high or low temperature during cooling operation or cold air dumping during heating operation (applies to VRF system)
- External control with thermostat
- Signal for frost protection, thermostat ON/OFF outputs
- External control with 0-10V signal
- Can be connected to an overall control system. Pay special attention to the electrical noise depending on the relevant system
- The control signal to the fan from the AHU kit can be used to control the air flow rate (high/medium/low). External relay

**System & regulations. System overview**

1. AHU Kit equipment (field supplied)
2. AHU Kit system controller (field supplied)
3. AHU Kit controller box (with control PCB)
4. Thermistor for gas pipe (E2)
5. Thermistor for liquid pipe (E1)
6. Thermistor for suction air
7. Inter-unit wiring
8. Outdoor unit

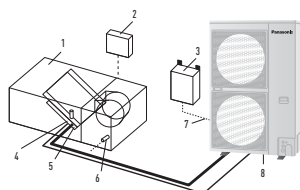

**Technical focus**

- Maximum capacity/system: 60 HP (168 kW)
- Maximum piping length: 100 m (120 m equivalent)
- Elevation difference (indoor unit / indoor unit): 4 m
- In/Out capacity ratio: 50~100 %
- Maximum indoor unit number: 3 units\*
- Outdoor temperature range in heating: -20 ~ +15 °C
- Available temperature range for the suction air at AHU Kit: cool: +18 ~ +32 °C / heat: +16 ~ +30 °C

\* To be simultaneous operation controlled by one remote controller sensor.

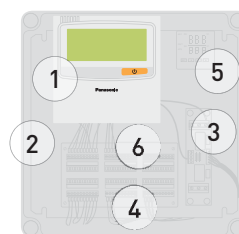

1. Remote control CZ-RTC
2. Plastic IP 65 Box
3. PAW-T10 PCB for Dry Contact
4. 0-10V demand control PCB
5. Intelligent thermostat for:
  - Cold draft prevention
  - Outdoor temperature shift compensation
6. Terminal base for sensors and power supply

**AHU Connection Kit**



PCB, Power trans, Terminal block



Thermistor x2 (Refrigerant: E1, E2)



Thermistor (Air: TA; 1 sensor)



Standard wired remote controller.

AHU PACi Elite	Cooling capacity	Heating capacity	Dimensions	Piping length	Elevation difference (in/out)
	Nominal kW	Nominal kW	H x W x D mm	Min / Max m	Max m
PAW-280PAH2	6,00 / 25,00	7,00 / 28,00	278x278x180	5 / 30*	10
PAW-280PAH2+PAW-280PAH2	50,00	56,00	278x278x180	5 / 30*	10

\* For U-200PE2E8A and U-250PE2E8A.

AHU connection kit / System combination	Air volume Min / Max m³/min	Dimensions H x W x D mm	Piping length Min / Max m	Elevation difference (in/out) Max m	Piping connections	
					Liquid pipe Inch (mm)	Gas pipe Inch (mm)
<b>Outdoor unit capacity</b>						
<b>5,0 kW</b>	PAW-280PAH2	8,00 / 13,00	278x278x180	5/30	10	1/4 (6,35) 1/2 (12,70)
<b>6,0 kW</b>	PAW-280PAH2	9,00 / 16,00	278x278x180	5/30	10	3/8 (9,62) 5/8 (15,88)
<b>7,5 kW</b>	PAW-280PAH2	12,00 / 25,00	278x278x180	5/30	10	3/8 (9,62) 5/8 (15,88)
<b>10,0 kW</b>	PAW-280PAH2	14,00 / 33,00	278x278x180	5/30	10	3/8 (9,62) 5/8 (15,88)
<b>12,5 kW</b>	PAW-280PAH2	19,00 / 35,00	278x278x180	5/30	10	3/8 (9,62) 5/8 (15,88)
<b>14,0 kW</b>	PAW-280PAH2	19,00 / 35,00	278x278x180	5/30	10	3/8 (9,62) 5/8 (15,88)
<b>20,0 kW</b>	PAW-280PAH2	28,00 / 66,00	278x278x180	5/70	10	3/8 (9,62) 1 (25,40)
<b>25,0 kW</b>	PAW-280PAH2	38,00 / 74,00	278x278x180	5/70	10	1/2 (12,70) 1 (25,40)

**Accessories**

<b>PAW-RC2-MBS-1</b>	Interface for connection to Modbus. For control of one unit via AHU kit with Modbus. 0-10V control is included
<b>PAW-RC2-MBS-4</b>	Interface for connection to Modbus. For control of four units via AHU kit with Modbus. 0-10V control distributed per AHU control included
<b>PAW-RC-KNX-1i</b>	Interface for connection to KNX. For control of one unit via AHU kit with KNX

**Accessories**

<b>PAW-WTRAY</b>	Tray for condenser water compatible with outdoor elevation platform
<b>PAW-GRDBSE20</b>	Outdoor base ground support for noise and vibration absorption
<b>PAW-GRDSTD40</b>	Outdoor elevation platform 400 x 900 x 400 mm
<b>PAW-WPH9</b>	Wind protection shield for U-71PZH2E5/8
<b>PAW-WPH7</b>	Wind protection shield for U-100/125/140PZH2E5/8

Weather/snow hoods for PACi and ECOi outdoor units are necessary in order to achieve high performance in heating and cooling in severe climates. Weather/snow hoods are obligatory under heating and cooling operation with AHU. Weather/snow hoods are made of DX51D galvanized steel with RAL9002, easy to install thanks to preinstalled cage nuts. Anti-vibration rubber on contact surfaces. Laser cut, with rounded edges for easier installation and cleaning.

# Panasonic PACi Elite can cool rooms down to 8 °C

Special application such as wine cellars.

**COOLING ROOMS  
BETWEEN 8 °C WB  
AND 24 °C WB**



## Solutions for cold rooms. Set the room temperature to 8 °C

There is a complete range, from 3,6 to 22,0 kW. This unique solution is perfect for: Wine cellars, ice cream factories, flower shops, supermarkets, grain stores, food storage, food processing,

food distribution, lunchrooms, vegetable processing... Just like all the indoor units in the PACi range, these units can be monitored via the Internet, generating an alarm if there is a breakdown.

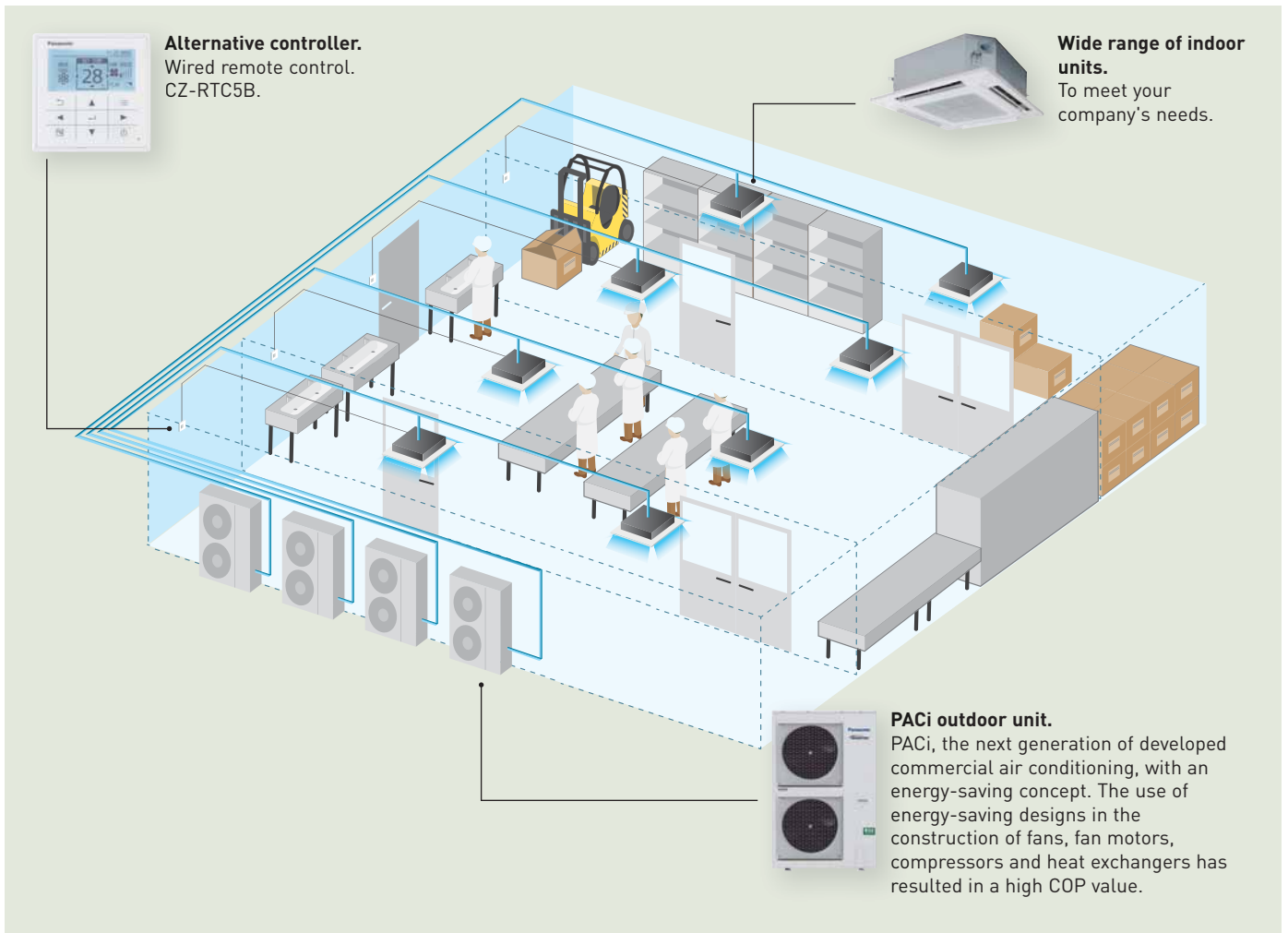



### Wine cellars and special low temperature rooms

One of the main features of the PACi series is the possibility of adjusting the product for special applications, not just for regular heating and cooling applications. The purpose of this product information is to explain in detail these special applications that need a cooling operation to maintain the room temperature at +8 ~ +24 °C WB (or +10 ~ +30 °C DB). In order to do this in terms of enthalpy, the indoor unit needs to be oversized and certain parameters need to be adjustable.

#### Temperature range for wine cellar

	Indoor	Outdoor
Cooling operation	+8 ~ +24 °C WB	-5 (-15) ~ 43 °C DB

#### Temperature range – temperature range for wine cellar.

In cooling. Outdoor air intake temperature °C DB

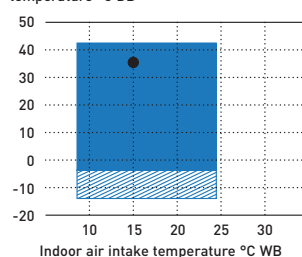

In heating. Outdoor air intake temperature °C WB

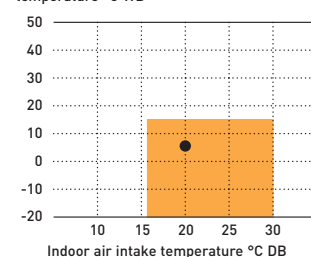

Only allowed after installation of wind and snow vents.



Area where cooling and heating capacity is established for this purpose.

### Examples of installations:

To avoid the growth of bacteria and to increase food safety: Wine cellars, ice cream factories, flower shops, broiler factories, pantries in hotels, supermarkets, grain stores, food storage, food processing, food distribution, lunchrooms, salad processing ...

Application	Single						Twin		
	3,5 kW	4,9 kW	5,8 kW	6,9 kW	9,3 kW	11,6 kW	13,6 kW	18,5 kW	23,2 kW
Cooling capacity	U-36PZH2E5	U-50PZH2E5	U-60PZH2E5	U-71PZH2E5 U-71PZH2E8	U-100PZH2E5 U-100PZH2E8	U-125PZH2E5 U-125PZH2E8	U-140PZH2E5 U-140PZH2E8	U-200PZH2E8	U-250PZH2E8
PACi outdoor units									
PACi indoor units				S-60PK2E5B + S-60PK2E5B	S-71PK2E5B + S-71PK2E5B	S-71PK2E5B + S-71PK2E5B	S-100PK2E5B + S-100PK2E5B	—	—
	S-60PU2E5B	S-71PU2E5B	S-100PU2E5B	S-125PU2E5B	S-140PU2E5B	S-140PU2E5B	S-100PU2E5B + S-100PU2E5B	S-125PU2E5B + S-125PU2E5B	S-140PU2E5B + S-140PU2E5B
	S-60PT2E5B	S-71PT2E5B	S-100PT2E5B	S-125PT2E5B	S-140PT2E5B	S-140PT2E5B	S-100PT2E5B + S-100PT2E5B	S-125PT2E5B + S-125PT2E5B	S-140PT2E5B + S-140PT2E5B
	S-60PF1E5B	S-71PF1E5B	S-100PF1E5B	S-125PF1E5B	S-140PF1E5B	S-140PF1E5B	S-100PF1E5B + S-100PF1E5B	S-125PF1E5B + S-125PF1E5B	S-140PF1E5B + S-140PF1E5B
	S-60PN1E5B	S-71PN1E5B	S-100PN1E5B	S-125PN1E5B	S-140PN1E5B	S-140PN1E5B	S-100PN1E5B + S-100PN1E5B	S-125PN1E5B + S-125PN1E5B	S-140PN1E5B + S-140PN1E5B

\* Above combinations require a special field setting. Please contact authorized Panasonic dealer.

# Panasonic AC Smart Cloud

With Panasonic AC Smart Cloud, have your business under control, and start saving!



## Flexible and scalable solution

- Energy saving
- Zero downtime
- Site(s) management

Centralise control of your business premises, from wherever you are, 24/7/365. It doesn't matter how many sites you have, or where they are! The AC Smart Cloud

system from Panasonic allows you to have complete control of all your installations from your tablet or from your computer. In a simple click, all your units from several locations, receive status updates in real-time of all your installations, reducing potential breakdowns and optimizing costs.

### Flexible solution for your business



Every time



Everywhere



Multiplatform



Internet browser

### Scalable solution for your business



Small to large



1 to multi sites



Upgrade features\*



PACi / ECOi

\* Customized to meet user demand / Continuous upgrades: new functions and product introductions / IT smart management.

## Panasonic AC Smart Cloud offers continuous improvement always thinking about users

### e-CUT function

e-CUT functions are newly available in Panasonic AC Smart Cloud. 5 energy saving settings reduces automatically its energy consumption.

**1. Set temperature auto return.**  
When you want to return to the set temperature after a certain time even if the temperature is changed.

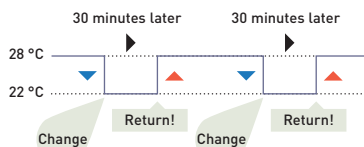

**2. Unattended auto shut off.**  
When you want to operate outside of a schedule but to monitor and stop automatically.

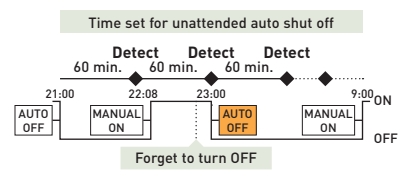

**3. Set temperature range limit.**  
When you want to limit the temperatures that can be set.

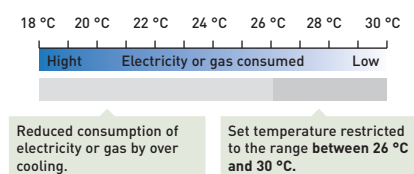

**4. Energy saving timer / efficient operation setting.**  
Specify time slots when you want operation capacity reduced.

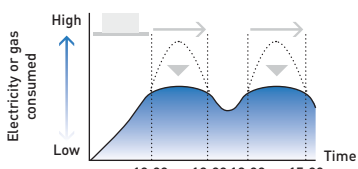

**5. Demand / peak shaving settings/ peak cut settings.**  
Specify time slots when you want operation capacity of the outdoor units reduced.

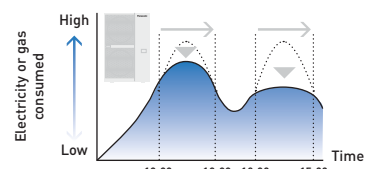

## Key functions and uniqueness

### Multi site monitoring.

- It doesn't matter how many sites you have, easy to manage, operate, compare sites, locations, rooms.



### Schedule setting.

- Yearly / weekly / holiday timer setting as you want



### Powerful statistics for energy savings.

- Power consumption, capacity, efficiency level can be compared with different parameters (Yearly / monthly / weekly / daily bases)



### Maintenance notification.

- Error notification by email and with floor layout
- Maintenance notification of ECO outdoor units
- Remote service checker function



### User customization <sup>1)</sup>.

Site administrator can create users as desired and assign customized profiles.

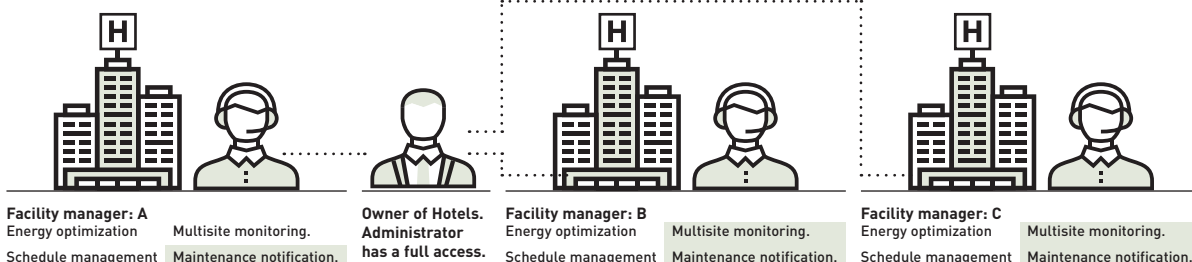

## Main functions per user type

Function / Main Tab	Sub-Tab	Basic type (Eg.: Owners, facility managers)	Professional type (Eg.: Installers, maintenance companies)
AC setting	I_U / O_U operation details	✓	✓
	Cloud adapter (CZ-CFUSCC1) details	✓	✓
	AC maintenance	✓	✓
	Map view	✓	✓
Energy saving function	e-CUT	✓	✓
Schedule	Yearly, weekly schedule setting / view	✓	✓
Powerful statistics	Power consumption	✓	
	Capacity	✓	
	Efficiency ranking	✓	

Function / Main Tab	Sub-Tab	Basic type (Eg.: Owners, facility managers)	Professional type (Eg.: Installers, maintenance companies)
Maintenance function	Notification overview / details	✓	✓
	Maintenance settings	✓	✓
	Map view	✓	✓
	Remote service checker	✓	✓
User account <sup>1)</sup>	New / update user registration	✓	
	Distribution group overview / details	✓	
System setting	Cut OFF request	✓	
	Map editor		✓

## One of our uniqueness is “stable and secured communication package”

- Connectivity is included in the service. Customers do not have to take time to find and prepare suitable connectivity.
  - With an all inclusive service offering, the customer has peace of mind and a one stop shop for all AC Smart Cloud issues they may face including connectivity
- This reduces installation time, requiring no integration with existing IT network infrastructure.



## Remote service checker function

### Zero down time

- Quick analysis & response
- Time & Cost saving for service maintenance task

### Recording service checker parameters from wherever you are!

- Data duration: Max. 120 minutes
- Data frequency: 10 – 90 seconds
- Mode selection: With test run or Without test run
- Count down schedule setting available

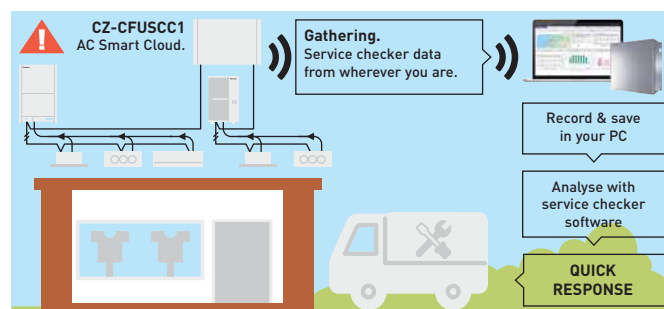

## Panasonic AC Smart Cloud parts lists

\* Cloud service fee is additionally required. Please contact an authorized Panasonic dealer.

CZ-CFUSCC1	AC Smart Cloud communication adaptor. Up to 128 groups. 128 units control
PAW-MVNOAC-V	3G communication package (SIM card included). V, K: Depending on countries <sup>1)</sup>
PAW-MVNOAC-K	

<sup>1)</sup> Please contact an authorized Panasonic dealer.

# Accessories and control

## Branch Pipes, Header



**CZ-P224BK2BM**  
Branch pipe (capacity after distribution is 22,4 kW or less).



**CZ-P680BK2BM**  
Branch pipe (from 22,4 kW to 68 kW).

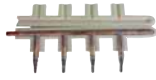

**CZ-P3HPC2BM**  
Header.

## Plenums



**CZ-DUMPA160MF2**  
Air Inlet Plenum for S...PF1E5B 100, 125 & 140.

**CZ-DUMPA90MF2**  
Air Inlet Plenum for S...PF1E5B 60 & 71.

**CZ-56DAF2**  
Air Outlet Plenum for S...PF1E5B 36, 45 & 50.

**CZ-90DAF2**  
Air Outlet Plenum for S...PF1E5B 60 & 71.

**CZ-160DAF2**  
Air Outlet Plenum for S...PF1E5B 100, 125 & 140.

**CZ-TREMIESPW705**  
Air Outlet Plenum for S-200PE2E5.

**CZ-TREMIESPW706**  
Air Outlet Plenum for S-250PE2E5.

## Outdoor accessories



**PAW-WTRAY**  
Tray for condenser water compatible with outdoor elevation platform.



**PAW-GRDSTD40**  
Outdoor elevation platform 400x900x400 mm.



**PAW-GRDBSE20**  
Outdoor base ground support for noise and vibration absorption (600 x 95 x 130 mm, 500kg).

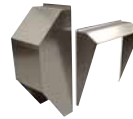

**PAW-WPH9**  
Wind protection shield for U-71PZH2E5/8, U-71PE1E5A/8A and U-100/125PEY1E5/8.



**PAW-WPH7**  
Wind protection shield for U-100/125/140PZH2E5/8, U-100/125/140PE1E5A/8A and U-140PEY1E8.

## Panels



**CZ-KPU3W**  
Standard panel for 4 Way 90x90 Cassette.



**CZ-KPU3AW**  
Econavi panel for 4 Way 90x90 Cassette.



**CZ-KPY3AW**  
Panel for 4 Way 60x60 Cassette size 700x700 mm.

**CZ-KPY3BW**  
Panel for 4 Way 60x60 Cassette size 625x625 mm.

## Other Accessory



**CZ-CNEXU1**  
nano X Generator Mark 1 kit for 4 Way 90x90 Cassette.



**CZ-CENSC1**  
Econavi energy savings sensor.



**CZ-CSRC3**  
Remote temperature sensor.

## VRF Smart Connectivity+



**SER8150R0B1194**  
Remote Controller Panasonic Net Con, RH, No PIR, R1/R2.

**SER8150R5B1194**  
Remote Controller Panasonic Net Con, RH, PIR, R1/R2.

**VCM8000V5094P**  
Wireless Zigbee Pro module / Green Com card.



**SEC-TEA-R-230-5045**  
Smart Terminal Controller ZigBee Pro High Power, External Antenna, 4UI/4A0/5D0, 220-240 VAC.

**SEC-TEA-R-24-5045**  
Smart Terminal Controller ZigBee Pro High Power, External Antenna, 4UI/4A0/5D0, 24 VAC.



**MPM-UN-014-5045**  
Universal network controller with Building Expert and StruXureWare integration, High Power, 6 I / 6O, Modbus.

**MPM-RAEC-5045**  
Universal network controller Cable extension.



**HRCEP14R**  
Hotel Room Expansion Module 14 indoor units.

**HRCPBG28R**  
Hotel Room Controller 28 indoor units.

**HRCPDG42R**  
Hotel Room Controller w/Display 42 indoor units.



**SED-WDC-G-5045**  
Door / window wireless sensor.



**SED-MTH-G-5045**  
Wall / ceiling (motion) wireless sensor.



**SED-CO2-G-5045**  
CO<sub>2</sub> sensor.



**SED-TRH-G-5045**  
Sensor with room temperature and humidity.



**SED-WLS-G-5045**  
Water leakage sensor.

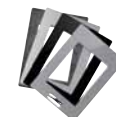

**FAS-00**  
Cover frame. Silver.

**FAS-01**  
White.

**FAS-03**  
Glossy translucent white.

**FAS-05**  
Light tan wood.

**FAS-06**  
Dark brown wood.

**FAS-07**  
Dark black wood.

**FAS-10**  
Brushed steel finish.

## Controller and touch controllers for Hotels with Dry Contacts



**PAW-RE2C4-MOD-WH**  
Modbus RS-485 touch room controller with I/O, White.

**PAW-RE2C4-MOD-BK**  
Modbus RS-485 touch room controller with I/O, Black.



**PAW-RE2D4-WH**  
Touch display control with 2 digital inputs, White.

**PAW-RE2D4-BK**  
Touch display control with 2 digital inputs, Black.

## Hotel sensors for Dry Contacts



**PAW-WMS-DC**  
Wall motion sensor 24 V.

**PAW-WMS-AC**  
Wall motion sensor 240 V AC.



**PAW-CMS-DC**  
Ceiling motion sensor 24 V.

**PAW-CMS-AC**  
Ceiling motion sensor 240 V AC.



**PAW-24DC**  
Power supply 24 V.



**PAW-DWC**  
Door or window contact.

Panasonic AC Smart Cloud



**CZ-CFUSCC1**  
Panasonic AC Smart Cloud. Cloud internet control. Up to 128 groups. Controls 128 units.

**PAW-MVNOAC-V**  
**PAW-MVNOAC-K**  
3G communication package (SIM Card included). V, K: Depending on countries.

Centralised Controls. Connection with 3rd Party Controller



**CZ-CAPDC2**  
Serial parallel device controlling outdoor units, up to 4 units.



**CZ-CAPC3**  
Adaptor for ON/OFF control of external devices.



**CZ-CAPBC2**  
Mini series parallel device controlling indoor units, maximum 1 group and 8 indoor unit.



**CZ-CFUNC2**  
Communication Adaptor. Up to 128 groups. Controls 128 units.

Accessories Interfaces



**CZ-CAPWFC1**  
Commercial Wi-Fi Adaptor.



**PAW-AC2-MBS-16P**  
**PAW-AC2-MBS-64P**  
**PAW-AC2-MBS-128P**  
Modbus Interface for 16, 64 or 128 indoor units.

**PAW-AC2-KNX-16P**  
**PAW-AC2-KNX-64P**  
KNX Interface for 16 or 64 indoor units.

**PAW-AC2-BAC-16P**  
**PAW-AC2-BAC-64P**  
**PAW-AC2-BAC-128P**  
BACnet Interface for 16, 64 or 128 indoor units.



**PAW-RC2-KNX-1i**  
KNX Interface.



**PAW-RC2-MBS-4**  
Modbus interface to control 4 indoor/groups.



**PAW-RC2-MBS-1**  
Modbus Interface.



**PAW-MBS-TCP2RTU**  
ModBus RTU Slave devices.



**PAW-RC2-BAC-1**  
BACnet Interface.



**CZ-TACG1**  
Panasonic Comfort Cloud for internet control.



**CZ-CAPRA1**  
RAC interface adapter for integration into P-Link, plus external input and alarm/status output.

Individual Controls



**CZ-RTC6\***  
**NEW** Wired remote controller (non-wireless).



**CZ-RTC5B**  
Design wired remote controller with Econavi function and datanavi.



**CZ-RWS3 + CZ-RWRU3W**  
Infrared remote controller for 4 Way 90x90 Cassette.



**CZ-RWS3**  
Infrared remote controller for Wall-mounted and 4 Way 60x60 with panel.



**CZ-RWS3 + CZ-RWRT3**  
Infrared remote controller for Ceiling.



**CZ-RWS3 + CZ-RWRC3**  
Infrared remote controller for all indoor units.

**CZ-RTC6BL\***  
**NEW** Wired remote controller with Bluetooth®.

Centralised Controls



**CZ-64ESMC3**  
System Controller with Schedule timer. Operation with various function from center station.



**CZ-ANC3**  
Central ON/OFF controller, up to 16 groups, 64 indoor units.



**CZ-256ESMC3**  
Simplified load distribution ratio (LDR) for each tenant. Intelligent Controller (Touch screen panel).

Accessories PCB



**PAW-T10**  
T10 interface PCB with digital and relay connections.



**PAW-PACR3**  
Redundancy of 2 or 3 systems; for PACi and ECOi.



**PAW-SERVER-PKEA**  
Redundancy of 2 units TKEA.

Accessories Cables



**CZ-T10**  
Cable for all the T10 functions.



**PAW-FDC**  
Cable to operate external EC fan.



**PAW-OCT**  
Cable for all option monitoring signals.

**PAW-EXCT**  
Cable with force Thermo OFF/leakage Detection.

ECO *i* EX

ECO *i*



## Commercial VRF Systems

Professional solutions for commercial projects.

Panasonic VRF System is specifically designed for energy saving, easy installation and high efficiency performance, with a wide choice of outdoor and indoor unit models and unique features which are designed for the most demanding offices and big buildings.



## Mini ECOi LE Series.

The Mini ECOi combines smartly compact body with high specifications. It delivers high levels of energy saving, powerful operation, reliability and comfort.



## VRF Systems ECOi EX.

A game-changing VRF system delivering outstanding energy saving performance. Taking quality to the extreme -that's the challenge by Panasonic.

## BMS interface with P-Link.

BMS interface with Panasonic communication bus helps you to get significant savings.



## VRF Smart Connectivity+.

Panasonic's VRF Smart Connectivity+ is a completely new, state-of-the-art solution providing energy saving and comfort as well as simple installation, operation and running.

## Panasonic AC Smart Cloud.

Centralised control of your business premises, from wherever 24/7. AC Smart Cloud offers continuous improvement always thinking about users.



# Range of VRF outdoor units

Page Outdoor units 4 HP 5 HP 6 HP 8 HP 10 HP

**P. 180** Mini ECOi LE2 / LE1 Series



U-4LE2E5 / U-4LE2E8



U-5LE2E5 / U-5LE2E8



U-6LE2E5 / U-6LE2E8



U-8LE1E8



U-10LE1E8

**P. 182** 2-Pipe ECOi EX ME2 Series



U-8ME2E8



U-10ME2E8

**P. 188** 3-Pipe ECOi EX MF3 Series



U-8MF3E8



U-10MF3E8

12 HP

14 HP

16 HP

18 HP

20 HP



U-12ME2E8



U-14ME2E8



U-16ME2E8



U-18ME2E8



U-20ME2E8



U-12MF3E8



U-14MF3E8



U-16MF3E8

# Mini ECOi LE Series



For light commercial & residential use. The most flexible VRF system ever. Meeting the needs of light commercial applications.



## 1 Efficiency energy control

Upgraded outdoor units deliver high efficiency rating and reduced energy costs.

## 2 Space saving

Ideal for commercial locations with limited space such as banks and shops. Compact units integrate easily and discreetly into building design.

## 3 Flexible installation

Reduced installation time thanks to compact units and extra long piping without additional refrigeration charge. High external static pressure 35Pa and small chassis increase installation options.

**7,9** | **4,9\***  
**SEER** | **SCOP**  
**INDUSTRY LEADING EFFICIENCY**

**6,4\***  
**SEER**  

---

**4,3**  
**SCOP**

### Compact design: LE2 Series - 4 / 5 / 6 HP

- Extraordinary energy saving: 7,9 SEER and 4,9 SCOP (4 HP)\*
- 50 m piping length without additional refrigerant charge
- Quiet operation mode with 4 levels
- High COP mode option

### LE1 Series - 8 / 10 HP

- 60 % smaller than ECOi ME2 8 / 10 HP with vertical flow type
- Flexible piping length (Total: 300 m, Furthest: 150 m)
- Maximum number of connectable indoor units: 15

\* SEER/SCOP is calculated based on the seasonal space cooling/heating efficiency "η" values of the COMMISSION REGULATION (EU) 2016/2281. SEER, SCOP = (η + Correction) × PEF.

### Key features for LE2 / LE1

**High external static pressure 35Pa — Full range of ECOi indoor units and controllers — Variable evaporation temperature control as standard — Connectable maximum indoor / outdoor capacity ratio up to 130 % — Auto restart from outdoor units — Demand response (Peak cut) by optional parts — Suitable for R22 renewable projects**



**COMPACT DESIGN**

**Mini ECOi LE Series**

HP			4 HP	5 HP	6 HP	4 HP	5 HP	6 HP	8 HP	10 HP
Outdoor units			U-4LE2E5	U-5LE2E5	U-6LE2E5	U-4LE2E8	U-5LE2E8	U-6LE2E8	U-8LE1E8	U-10LE1E8
Power supply	Voltage	V	220-230-240	220-230-240	220-230-240	380-400-415	380-400-415	380-400-415	380-400-415	380-400-415
	Phase		Single Phase	Single Phase	Single Phase	Three Phase	Three Phase	Three Phase	Three Phase	Three Phase
	Frequency	Hz	50	50	50	50	50	50	50	50
Cooling capacity	kW		12,1	14,0	15,5	12,1	14,0	15,5	22,4	28,0
EER <sup>1)</sup>	W/W		4,50	4,06	3,73	4,50	4,06	3,73	3,80	3,11
SEER <sup>2)</sup>			<b>7,9</b>	<b>7,5</b>	<b>7,3</b>	<b>7,9</b>	<b>7,5</b>	<b>7,3</b>	<b>6,3</b>	<b>6,4</b>
Running current cooling	A		13,30/12,70/12,20	16,30/15,60/17,00	20,30/19,40/18,60	4,39/4,17/4,02	5,58/5,30/5,11	6,71/6,37/6,14	9,60/9,15/8,80	14,70/14,00/13,50
Input power cooling	kW		2,69	3,45	4,15	2,69	3,45	4,15	5,89	9,00
Heating capacity	kW		12,5	16,0	16,5	12,5	16,0	16,5	25,0	28,0
COP <sup>1)</sup>	W/W		5,19	4,60	4,27	5,19	4,60	4,27	4,02	3,93
SCOP <sup>2)</sup>			<b>4,9</b>	<b>4,4</b>	<b>4,2</b>	<b>4,9</b>	<b>4,4</b>	<b>4,2</b>	<b>4,2</b>	<b>4,3</b>
Running current heating	A		12,20/11,60/11,20	17,60/16,80/16,10	19,10/18,20/17,50	3,98/3,78/3,64	5,62/5,34/5,14	6,24/5,93/5,71	10,20/9,65/9,30	11,60/11,10/10,70
Input power heating	kW		2,41	3,48	3,86	2,41	3,48	3,86	6,22	7,13
Starting current	A		1,00	1,00	1,00	1,00	1,00	1,00	1,00	1,00
Maximum current	A		17,30	24,30	27,40	7,90	10,10	10,70	13,70	19,60
Maximum input power	kW		3,50/3,66/3,82	4,92/5,14/5,37	5,61/5,86/6,12	4,34/5,09/5,28	6,25/6,55/6,82	6,62/6,97/7,23	9,16	13,10
Maximum number of connectable indoor units			7(10) <sup>3)</sup>	8(10) <sup>3)</sup>	9(12) <sup>3)</sup>	7(10) <sup>3)</sup>	8(10) <sup>3)</sup>	9(12) <sup>3)</sup>	15 <sup>4)</sup>	15 <sup>4)</sup>
External static pressure	Pa		0~35	0~35	0~35	0~35	0~35	0~35	0~35	0~35
Air volume	m <sup>3</sup> /min		69	72	74	69	72	74	150	160
Sound pressure	Cool	dB(A)	52	53	54	52	53	53	60	63
	Cool [Silent1/2/3/4]	dB(A)	50,5/49/47/45	51,5/50/48/46	52,5/51/48/46	50,5/49/49/47	48,5/50/48/46	48,5/50/48/46	57/55/53	60/58/56
	Heat	dB(A)	54	56	56	54	56	56	64	65
Sound power	Cool / Heat	dB(A)	69/72	71/75	73/75	69/72	71/75	73/75	81/85	84/86
Dimension	H x W x D	mm	996 x 980 x 370	996 x 980 x 370	996 x 980 x 370	996 x 980 x 370	996 x 980 x 370	996 x 980 x 370	1500 x 980 x 370	1500 x 980 x 370
Net weight	kg		106	106	106	106	106	106	132	133
Piping connections	Liquid pipe	Inch (mm)	3/8(9,52)	3/8(9,52)	3/8(9,52)	3/8(9,52)	3/8(9,52)	3/8(9,52)	3/8(9,52) <sup>5)</sup> 1/2(12,70) <sup>4)</sup>	3/8(9,52) <sup>5)</sup> 1/2(12,70) <sup>4)</sup>
	Gas pipe	Inch (mm)	5/8(15,88)	5/8(15,88)	5/8(15,88)	5/8(15,88)	5/8(15,88)	5/8(15,88)	3/4(19,05) <sup>5)</sup> 7/8(22,22) <sup>4)</sup>	7/8(22,22) <sup>5)</sup> 1(25,40) <sup>4)</sup>
Maximum piping length (total)	m		150(180)	150(180)	150(180)	150(180)	150(180)	150(180)	7,5~150 (7,5~300)	7,5~150 (7,5~300)
Elevation difference (in/out)	m		50(Outdoor unit upper)/ 40(Outdoor unit lower)	50(Outdoor unit upper)/ 40(Outdoor unit lower)	50(Outdoor unit upper)/ 40(Outdoor unit lower)	50(Outdoor unit upper)/ 40(Outdoor unit lower)	50(Outdoor unit upper)/ 40(Outdoor unit lower)	50(Outdoor unit upper)/ 40(Outdoor unit lower)	50(Outdoor unit upper)/ 40(Outdoor unit lower)	50(Outdoor unit upper)/ 40(Outdoor unit lower)
Refrigerant (R410A) / CO <sub>2</sub> Eq.	kg / T		6,70(14,40)/ 13,9896	6,70(14,40)/ 13,9896	6,70(14,40)/ 13,9896	6,70(14,40)/ 13,9896	6,70(14,40)/ 13,9896	6,70(14,40)/ 13,9896	6,30(24,00)/ 13,1544	6,60(24,00)/ 13,7808
Maximum allowable indoor / outdoor capacity ratio	%		50~130	50~130	50~130	50~130	50~130	50~130	50~130	50~130
Operating range	Cool Min ~ Max	°C	-10~+46	-10~+46	-10~+46	-10~+46	-10~+46	-10~+46	-10~+46	-10~+46
	Heat Min ~ Max	°C	-20~+18	-20~+18	-20~+18	-20~+18	-20~+18	-20~+18	-20~+18	-20~+18

1) EER and COP calculation is based in accordance to EN14511. 2) SEER/SCOP is calculated based on the seasonal space cooling/heating efficiency "η" values of the COMMISSION REGULATION (EU) 2016/2281. SEER, SCOP = (η + Correction) x PEF. 3) In case of 1,5 kW indoor unit's connection, able to connect maximum 12 indoor units. 4) If the heating utilized, it is necessary to increase 1 size with respect to the main liquid pipe, depending on the combination of the indoor unit. 5) Under 90 m for ultimate indoor unit. 6) Over 90 m for ultimate indoor unit. If the longest piping equivalent length exceeds 90 m, increase the sizes of the main tubes by 1 rank for gas and liquid pipes.



INTERNET CONTROL: Optional.



## 2-Pipe ECOi EX ME2 Series



Energy saving performance, powerful operation, reliability and comfort surpassing anything previously possible.



### High performance at extreme conditions

ECOi EX is highly reliable, with strong cooling and heating power, even when operating at extreme ambient temperatures. The units can operate at 100 % of capacity at 43 °C, reaching a great cooling operation up to 52 °C and in heating -25 °C.

Also, the ECOi EX features include Bluefin in newly designed heat exchanger improving efficiency as well in marine ambient. A silicone coated PCB (Printed Circuit Board) protects the unit from being damaged by environmental factors such as moisture and dust.

### Superior flexibility

With its up to 1000 meters of pipeline, its maximum 30 meters height difference between indoor units and maximum 90 meters between outdoor unit and indoor unit, the design possibilities have grown exponentially making the new ECOi EX the ideal air conditioning option for expansive buildings, such as train stations, airports, schools or hospitals. These advantages are enhanced with the wide range of indoor unit models and capacities facilitating the perfect adaptation to all kind of projects. The careful selection of controls and peripherals such as the Pump Down, the AHU and/or the chiller, enables an optimum system use. Maximum allowable indoor / outdoor connected capacity ratio of up to 200 %.

**VRF with outstanding energy saving performance and powerful operation SEER 7,56 (18 HP model).**

### Outstanding efficiency and comfort

The new ECOi EX system is designed to increase energy efficiency by delivering high SEER rating, as well as high efficiency for part-load operations.

The system has reduced energy costs thanks to "All-Inverter Compressors", with independent control to deliver highly flexible performance. Also, the ECOi EX features an enlarged heat exchanger with triple surfaces that allow for improved heat transfer and a newly designed curved air discharge bell-mouth for better aerodynamics. The three-stage oil recovery design makes it able to minimise the frequency of forced oil recovery, leading to reduced energy costs and sustained comfort.

**Remarkable improvement on key components: extraordinary energy saving performance and redesigned for smooth and better air discharge.**

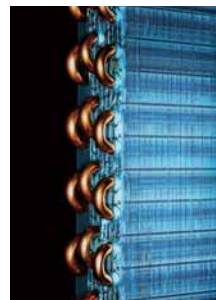

Enlarged heat exchanger surface area with triple surface.



Multiple large-capacity all inverter compressors (more than 14 HP).



Newly designed curved air discharge bell mouth for better aerodynamics.

\* For 8 and 10 HP unit, the heat exchanger is 2 row design.



### 2-Pipe ECOi EX ME2 Series

			8 HP	10 HP	12 HP	14 HP	16 HP	18 HP	20 HP
Outdoor units			U-8ME2E8	U-10ME2E8	U-12ME2E8	U-14ME2E8	U-16ME2E8	U-18ME2E8	U-20ME2E8
Power supply	Voltage	V	380-400-415	380-400-415	380-400-415	380-400-415	380-400-415	380-400-415	380-400-415
	Phase		Three Phase	Three Phase	Three Phase	Three Phase	Three Phase	Three Phase	Three Phase
	Frequency	Hz	50	50	50	50	50	50	50
Cooling capacity		kW	22,4	28,0	33,5	40,0	45,0	50,0	56,0
EER <sup>1)</sup>		W/W	4,70	4,37	3,96	3,88	3,52	3,52	3,35
ESEER		W/W	9,33	8,67	7,94	7,73	7,19	6,95	6,18
<b>SEER <sup>2)</sup></b>			<b>7,4</b>	<b>6,8</b>	<b>6,7</b>	<b>7,2</b>	<b>6,4</b>	<b>7,6</b>	<b>7,0</b>
Running current cooling		A	7,40/7,14	10,20/9,80	13,00/12,50	16,50/15,90	20,10/19,40	22,00/21,20	25,40/24,50
Input power cooling		kW	4,77	6,41	8,47	10,30	12,80	14,20	16,70
Heating capacity		kW	25,0	31,5	37,5	45,0	50,0	56,0	63,0
COP <sup>1)</sup>		W/W	5,13	4,76	4,73	4,56	4,42	4,38	3,94
<b>SCOP <sup>2)</sup></b>			<b>4,8</b>	<b>4,3</b>	<b>4,7</b>	<b>4,3</b>	<b>4,1</b>	<b>4,3</b>	<b>4,1</b>
Running current heating		A	7,56/7,29	10,50/11,10	12,30/11,80	15,80/15,20	17,90/17,30	20,10/19,40	24,60/23,70
Input power heating		kW	4,87	6,62	7,92	9,86	11,30	12,80	16,00
Starting current		A	1,00	1,00	1,00	2,00	2,00	2,00	2,00
External static pressure (Max)		Pa	80	80	80	80	80	80	80
Air volume		m <sup>3</sup> /min	224	224	232	232	232	405	405
Sound pressure	Normal mode	dB(A)	54	56	59	60	61	59	60
	Silent mode	dB(A)	51	53	56	57	58	56	57
Sound power	Normal mode	dB(A)	75	77	80	81	82	80	81
Dimension	HxWxD	mm	1842x770 x1000	1842x770 x1000	1842x1180 x1000	1842x1180 x1000	1842x1180 x1000	1842x1540 x1000	1842x1540 x1000
Net weight		kg	210	210	270	315	315	375	375
Piping connections <sup>3)</sup>	Liquid pipe	Inch (mm)	3/8(9,52)/ 1/2(12,70)	3/8(9,52)/ 1/2(12,70)	1/2(12,70)/ 5/8(15,88)	1/2(12,70)/ 5/8(15,88)	1/2(12,70)/ 5/8(15,88)	5/8(15,88)/ 3/4(19,05)	5/8(15,88)/ 3/4(19,05)
	Gas pipe	Inch (mm)	3/4(19,05)/ 7/8(22,22)	7/8(22,22)/ 1(25,40)	1(25,40)/ 1-1/8(28,58)	1(25,40)/ 1-1/8(28,58)	1-1/8(28,58)/ 1-1/4(31,75)	1-1/8(28,58)/ 1-1/4(31,75)	1-1/8(28,58)/ 1-1/4(31,75)
	Balance pipe	Inch (mm)	1/4(6,35)	1/4(6,35)	1/4(6,35)	1/4(6,35)	1/4(6,35)	1/4(6,35)	1/4(6,35)
Refrigerant (R410A) / CO <sub>2</sub> Eq		kg/T	5,60/11,6928	5,60/11,6928	8,30/17,3304	8,30/17,3304	8,30/17,3304	9,50/19,836	9,50/19,836
Maximum allowable indoor / outdoor capacity ratio % <sup>4)</sup>			50~130(200)	50~130(200)	50~130(200)	50~130(200)	50~130(200)	50~130(200)	50~130(200)
Operating range	Cool Min ~ Max	°C	-10 ~ +52	-10 ~ +52	-10 ~ +52	-10 ~ +52	-10 ~ +52	-10 ~ +52	-10 ~ +52
	Heat Min ~ Max	°C	-25 ~ +18	-25 ~ +18	-25 ~ +18	-25 ~ +18	-25 ~ +18	-25 ~ +18	-25 ~ +18

1) EER and COP calculation is based in accordance to EN14511. 2) SEER/SCOP is calculated based on the seasonal space cooling/heating efficiency "η" values of the COMMISSION REGULATION (EU) 2016/2281. SEER, SCOP = [η + Correction] x PEF. 3) Pipe diameter under 90 m for ultimate indoor unit / over 90 m for ultimate indoor unit (if the longest piping equivalent length exceeds 90 m, increase the sizes of the main tubes by 1 rank for gas tubes and liquid tubes). 4) If the following conditions are satisfied, the effective range is above 130 % and below 200 %: A. Obey the limited number of connectable indoor units. B. The lower limit of operating range for heating outdoor temperature is limited to -10 °C WB (standard -25 °C WB). C. Simultaneous operation is limited to less than 130 % of connectable indoor units.



## 2-Pipe ECOi EX ME2 Series High Efficiency Model Combination from 18 to 28 HP

			18 HP	20 HP	22 HP	24 HP	26 HP	28 HP
			U-8ME2E8	U-10ME2E8	U-10ME2E8	U-12ME2E8	U-10ME2E8	U-12ME2E8
			U-10ME2E8	U-10ME2E8	U-12ME2E8	U-12ME2E8	U-16ME2E8	U-16ME2E8
Power supply	Voltage	V	380-400-415	380-400-415	380-400-415	380-400-415	380-400-415	380-400-415
	Phase		Three Phase	Three Phase	Three Phase	Three Phase	Three Phase	Three Phase
	Frequency	Hz	50	50	50	50	50	50
Cooling capacity		kW	50,0	56,0	61,5	68,0	73,0	78,5
EER <sup>1)</sup>		W/W	4,55	4,38	4,13	3,93	3,80	3,69
Running current cooling		A	17,30/16,60	20,30/19,60	23,10/22,30	26,60/25,60	30,10/29,00	33,10/31,90
Input power cooling		kW	11,00	12,80	14,90	17,30	19,20	21,30
Heating capacity		kW	56,0	63,0	69,0	76,5	81,5	87,5
COP <sup>1)</sup>		W/W	4,96	4,77	4,76	4,69	4,55	4,56
Running current heating		A	17,70/17,10	20,90/20,20	22,70/21,90	25,30/24,40	28,40/27,40	30,10/29,00
Input power heating		kW	11,30	13,20	14,50	16,30	17,90	19,20
Starting current		A	2,00	2,00	2,00	2,00	3,00	3,00
External static pressure (Max)		Pa	80	80	80	80	80	80
Air volume		m <sup>3</sup> /min	448	448	456	464	456	464
Sound pressure	Normal / Silent mode	dB(A)	58,50/55,50	59,00/56,00	61,00/58,00	62,00/59,00	62,50/59,50	63,50/60,50
Sound power	Normal mode	dB(A)	79,50	80,00	82,00	83,00	83,50	84,50
Dimension / Net weight	H x W x D	mm / kg	1842 x 1600 x 1000 / 420	1842 x 1600 x 1000 / 420	1842 x 2010 x 1000 / 480	1842 x 2420 x 1000 / 540	1842 x 2010 x 1000 / 535	1842 x 2420 x 1000 / 585
Piping connections <sup>2)</sup>	Liquid pipe	Inch (mm)	5/8(15,88)/3/4(19,05)	5/8(15,88)/3/4(19,05)	5/8(15,88)/3/4(19,05)	5/8(15,88)/3/4(19,05)	3/4(19,05)/7/8(22,22)	3/4(19,05)/7/8(22,22)
	Gas pipe	Inch (mm)	1-1/8(28,58)/1-1/4(31,75)	1-1/8(28,58)/1-1/4(31,75)	1-1/8(28,58)/1-1/4(31,75)	1-1/8(28,58)/1-1/4(31,75)	1-1/4(31,75)/1-1/2(38,10)	1-1/4(31,75)/1-1/2(38,10)
	Balance pipe	Inch (mm)	1/4(6,35)	1/4(6,35)	1/4(6,35)	1/4(6,35)	1/4(6,35)	1/4(6,35)
Refrigerant (R410A) / CO <sub>2</sub> Eq.		kg / T	11,20/23,3856	11,20/23,3856	13,90/29,0232	16,60/34,6608	13,90/29,0232	16,60/34,6608
Maximum allowable indoor / outdoor capacity ratio % <sup>3)</sup>			50 ~ 130(200)	50 ~ 130(200)	50 ~ 130(200)	50 ~ 130(200)	50 ~ 130(200)	50 ~ 130(200)
Operating range	Cool Min ~ Max	°C	-10 ~ +52	-10 ~ +52	-10 ~ +52	-10 ~ +52	-10 ~ +52	-10 ~ +52
	Heat Min ~ Max	°C	-25 ~ +18	-25 ~ +18	-25 ~ +18	-25 ~ +18	-25 ~ +18	-25 ~ +18

## 2-Pipe ECOi EX ME2 Series High Efficiency Model Combination from 30 to 40 HP

			30 HP	32 HP	34 HP	36 HP	38 HP	40 HP
			U-14ME2E8	U-16ME2E8	U-10ME2E8	U-12ME2E8	U-10ME2E8	U-12ME2E8
			U-16ME2E8	U-16ME2E8	U-12ME2E8	U-12ME2E8	U-12ME2E8	U-12ME2E8
			U-12ME2E8	U-12ME2E8	U-12ME2E8	U-12ME2E8	U-16ME2E8	U-16ME2E8
Power supply	Voltage	V	380-400-415	380-400-415	380-400-415	380-400-415	380-400-415	380-400-415
	Phase		Three Phase	Three Phase	Three Phase	Three Phase	Three Phase	Three Phase
	Frequency	Hz	50	50	50	50	50	50
Cooling capacity		kW	85,0	90,0	96,0	101,0	107,0	113,0
EER <sup>1)</sup>		W/W	3,68	3,52	4,05	3,95	3,84	3,75
Running current cooling		A	36,60/35,30	40,20/38,70	36,80/35,50	39,30/37,90	43,80/42,20	46,70/45,00
Input power cooling		kW	23,10	25,60	23,70	25,60	27,90	30,10
Heating capacity		kW	95,0	100,0	108,0	113,0	119,0	127,0
COP <sup>1)</sup>		W/W	4,48	4,42	4,72	4,73	4,61	4,57
Running current heating		A	33,60/32,40	35,80/34,60	35,90/34,60	37,10/35,80	40,50/39,00	43,60/42,00
Input power heating		kW	21,20	22,60	22,90	23,90	25,80	27,80
Starting current		A	4,00	4,00	3,00	3,00	4,00	4,00
External static pressure (Max)		Pa	80	80	80	80	80	80
Air volume		m <sup>3</sup> /min	464	464	688	696	688	696
Sound pressure	Normal / Silent mode	dB(A)	63,50/60,50	64,00/61,00	63,00/60,00	64,00/61,00	64,00/61,00	64,50/61,50
Sound power	Normal mode	dB(A)	84,50	85,00	84,00	85,00	85,00	85,50
Dimension / Net weight	H x W x D	mm / kg	1842 x 2420 x 1000 / 630	1842 x 2420 x 1000 / 630	1842 x 3250 x 1000 / 750	1842 x 3660 x 1000 / 810	1842 x 3250 x 1000 / 795	1842 x 3660 x 1000 / 855
Piping connections <sup>2)</sup>	Liquid pipe	Inch (mm)	3/4(19,05)/7/8(22,22)	3/4(19,05)/7/8(22,22)	3/4(19,05)/7/8(22,22)	3/4(19,05)/7/8(22,22)	3/4(19,05)/7/8(22,22)	3/4(19,05)/7/8(22,22)
	Gas pipe	Inch (mm)	1-1/4(31,75)/1-1/2(38,10)	1-1/4(31,75)/1-1/2(38,10)	1-1/4(31,75)/1-1/2(38,10)	1-1/2(38,10)/1-5/8(41,28)	1-1/2(38,10)/1-5/8(41,28)	1-1/2(38,10)/1-5/8(41,28)
	Balance pipe	Inch (mm)	1/4(6,35)	1/4(6,35)	1/4(6,35)	1/4(6,35)	1/4(6,35)	1/4(6,35)
Refrigerant (R410A) / CO <sub>2</sub> Eq.		kg / T	16,60/34,6608	16,60/34,6608	22,20/46,3536	24,90/51,9912	22,20/46,3536	24,90/46,3536
Maximum allowable indoor / outdoor capacity ratio % <sup>3)</sup>			50 ~ 130(200)	50 ~ 130(200)	50 ~ 130(200)	50 ~ 130(200)	50 ~ 130(200)	50 ~ 130(200)
Operating range	Cool Min ~ Max	°C	-10 ~ +52	-10 ~ +52	-10 ~ +52	-10 ~ +52	-10 ~ +52	-10 ~ +52
	Heat Min ~ Max	°C	-25 ~ +18	-25 ~ +18	-25 ~ +18	-25 ~ +18	-25 ~ +18	-25 ~ +18

Data is for reference. 1) EER and COP calculation is based in accordance to EN14511. 2) Pipe diameter under 90 m for ultimate indoor unit / over 90 m for ultimate indoor unit (if the longest piping equivalent length exceeds 90 m, increase the sizes of the main tubes by 1 rank for gas tubes and liquid tubes). 3) If the following conditions are satisfied, the effective range is above 130 % and below 200 %: A. Obey the limited number of connectable indoor units. B. The lower limit of operating range for heating outdoor temperature is limited to -10 °C WB (standard -25 °C WB). C. Simultaneous operation is limited to less than 130 % of connectable indoor units.



## 2-Pipe ECOi EX ME2 Series High Efficiency Model Combination from 42 to 52 HP

			42 HP	44 HP	46 HP	48 HP	50 HP	52 HP
			U-10ME2E8	U-12ME2E8	U-14ME2E8	U-16ME2E8	U-10ME2E8	U-12ME2E8
			U-16ME2E8	U-16ME2E8	U-16ME2E8	U-16ME2E8	U-12ME2E8	U-12ME2E8
			U-16ME2E8	U-16ME2E8	U-16ME2E8	U-16ME2E8	U-16ME2E8	U-16ME2E8
Power supply	Voltage	V	380-400-415	380-400-415	380-400-415	380-400-415	380-400-415	380-400-415
	Phase		Three Phase	Three Phase	Three Phase	Three Phase	Three Phase	Three Phase
	Frequency	Hz	50	50	50	50	50	50
Cooling capacity		kW	118,0	124,0	130,0	135,0	140,0	145,0
EER <sup>1)</sup>		W/W	3,69	3,62	3,62	3,52	3,87	3,82
Running current cooling		A	50,20/48,40	53,20/51,30	56,90/54,90	60,20/58,10	56,20/54,20	59,00/56,80
Input power cooling		kW	32,00	34,30	35,90	38,40	36,20	38,00
Heating capacity		kW	132,0	138,0	145,0	150,0	155,0	160,0
COP <sup>1)</sup>		W/W	4,49	4,50	4,46	4,42	4,65	4,66
Running current heating		A	46,60/44,90	48,20/46,40	51,50/49,70	53,80/51,80	52,20/50,40	53,80/51,90
Input power heating		kW	29,40	30,70	32,50	33,90	33,30	34,30
Starting current		A	5,00	5,00	6,00	6,00	5,00	5,00
External static pressure (Max)		Pa	80	80	80	80	80	80
Air volume		m <sup>3</sup> /min	688	696	696	696	920	928
Sound pressure	Normal / Silent mode	dB(A)	65,00/62,00	65,50/62,50	65,50/62,50	66,00/63,00	65,50/62,50	66,00/63,00
Sound power	Normal mode	dB(A)	86,00	86,50	86,50	87,00	86,50	87,00
Dimension / Net weight	H x W x D	mm / kg	1842x3250 x1000/840	1842x3660 x1000/900	1842x3660 x1000/945	1842x3660 x1000/945	1842x4490 x1000/1065	1842x4900 x1000/1125
Piping connections <sup>2)</sup>	Liquid pipe	Inch (mm)	3/4(19,05)/ 7/8(22,22)	3/4(19,05)/ 7/8(22,22)	3/4(19,05)/ 7/8(22,22)	3/4(19,05)/ 7/8(22,22)	3/4(19,05)/ 7/8(22,22)	3/4(19,05)/ 7/8(22,22)
	Gas pipe	Inch (mm)	1-1/2(38,10)/ 1-5/8(41,28)	1-1/2(38,10)/ 1-5/8(41,28)	1-1/2(38,10)/ 1-5/8(41,28)	1-1/2(38,10)/ 1-5/8(41,28)	1-1/2(38,10)/ 1-5/8(41,28)	1-1/2(38,10)/ 1-5/8(41,28)
	Balance pipe	Inch (mm)	1/4(6,35)	1/4(6,35)	1/4(6,35)	1/4(6,35)	1/4(6,35)	1/4(6,35)
Refrigerant (R410A) / CO <sub>2</sub> Eq.		kg / T	22,20/51,9912	24,90/51,9912	24,90/51,9912	24,90/51,9912	30,50/63,6840	33,20/69,3216
Maximum allowable indoor / outdoor capacity ratio % <sup>3)</sup>			50-130(200)	50-130(200)	50-130(200)	50-130(200)	50-130(200)	50-130(200)
Operating range	Cool Min ~ Max	°C	-10 ~ +52	-10 ~ +52	-10 ~ +52	-10 ~ +52	-10 ~ +52	-10 ~ +52
	Heat Min ~ Max	°C	-25 ~ +18	-25 ~ +18	-25 ~ +18	-25 ~ +18	-25 ~ +18	-25 ~ +18

## 2-Pipe ECOi EX ME2 Series High Efficiency Model Combination from 54 to 64 HP

			54 HP	56 HP	58 HP	60 HP	62 HP	64 HP
			U-10ME2E8	U-12ME2E8	U-10ME2E8	U-12ME2E8	U-14ME2E8	U-16ME2E8
			U-12ME2E8	U-12ME2E8	U-16ME2E8	U-16ME2E8	U-16ME2E8	U-16ME2E8
			U-16ME2E8	U-16ME2E8	U-16ME2E8	U-16ME2E8	U-16ME2E8	U-16ME2E8
			U-16ME2E8	U-16ME2E8	U-16ME2E8	U-16ME2E8	U-16ME2E8	U-16ME2E8
Power supply	Voltage	V	380-400-415	380-400-415	380-400-415	380-400-415	380-400-415	380-400-415
	Phase		Three Phase	Three Phase	Three Phase	Three Phase	Three Phase	Three Phase
	Frequency	Hz	50	50	50	50	50	50
Cooling capacity		kW	151,0	156,0	162,0	168,0	174,0	180,0
EER <sup>1)</sup>		W/W	3,75	3,71	3,65	3,60	3,60	3,52
Running current cooling		A	63,20/60,90	65,30/63,00	69,70/67,10	73,30/70,60	75,80/73,00	80,30/77,40
Input power cooling		kW	40,30	42,10	44,40	46,70	48,30	51,20
Heating capacity		kW	169,0	175,0	182,0	189,0	195,0	201,0
COP <sup>1)</sup>		W/W	4,56	4,56	4,47	4,47	4,45	4,42
Running current heating		A	58,80/56,70	60,20/58,10	64,60/62,20	67,10/64,70	69,50/67,00	72,20/69,60
Input power heating		kW	37,10	38,40	40,70	42,30	43,80	45,50
Starting current		A	6,00	6,00	7,00	7,00	8,00	8,00
External static pressure (Max)		Pa	80	80	80	80	80	80
Air volume		m <sup>3</sup> /min	920	928	920	928	928	928
Sound pressure	Normal / Silent mode	dB(A)	66,00/63,00	66,50/63,50	66,50/63,50	67,00/64,00	67,00/64,00	67,00/64,00
Sound power	Normal mode	dB(A)	87,00	87,50	87,50	88,00	88,00	88,00
Dimension / Net weight	H x W x D	mm / kg	1842x4490 x1000/1110	1842x4900 x1000/1170	1842x4490 x1000/1155	1842x4900 x1000/1215	1842x4900 x1000/1260	1842x4900 x1000/1260
Piping connections <sup>2)</sup>	Liquid pipe	Inch (mm)	3/4(19,05)/ 7/8(22,22)	3/4(19,05)/ 7/8(22,22)	3/4(19,05)/ 7/8(22,22)	3/4(19,05)/ 7/8(22,22)	3/4(19,05)/ 7/8(22,22)	3/4(19,05)/ 7/8(22,22)
	Gas pipe	Inch (mm)	1-1/2(38,10)/ 1-5/8(41,28)	1-1/2(38,10)/ 1-5/8(41,28)	1-1/2(38,10)/ 1-5/8(41,28)	1-1/2(38,10)/ 1-5/8(41,28)	1-5/8(41,28)/ 1-3/4(44,45)	1-5/8(41,28)/ 1-3/4(44,45)
	Balance pipe	Inch (mm)	1/4(6,35)	1/4(6,35)	1/4(6,35)	1/4(6,35)	1/4(6,35)	1/4(6,35)
Refrigerant (R410A) / CO <sub>2</sub> Eq.		kg / T	30,50/63,6840	33,20/69,3216	30,50/63,6840	33,20/69,3216	33,20/69,3216	33,20/69,3216
Maximum allowable indoor / outdoor capacity ratio % <sup>3)</sup>			50-130(200)	50-130(200)	50-130(200)	50-130(200)	50-130(200)	50-130(200)
Operating range	Cool Min ~ Max	°C	-10 ~ +52	-10 ~ +52	-10 ~ +52	-10 ~ +52	-10 ~ +52	-10 ~ +52
	Heat Min ~ Max	°C	-25 ~ +18	-25 ~ +18	-25 ~ +18	-25 ~ +18	-25 ~ +18	-25 ~ +18

Data is for reference. 1) EER and COP calculation is based in accordance to EN14511. 2) Pipe diameter under 90 m for ultimate indoor unit / over 90 m for ultimate indoor unit (if the longest piping equivalent length exceeds 90 m, increase the sizes of the main tubes by 1 rank for gas tubes and liquid tubes). 3) If the following conditions are satisfied, the effective range is above 130 % and below 200 %: A. Obey the limited number of connectable indoor units. B. The lower limit of operating range for heating outdoor temperature is limited to -10 °C WB (standard -25 °C WB). C. Simultaneous operation is limited to less than 130 % of connectable indoor units.

2-Pipe ECOi EX ME2 Series Space Saving Model Combination from 22 to 34 HP

			22 HP	24 HP	26 HP	28 HP	30 HP	32 HP	34 HP
Model name			U-10ME2E8	U-12ME2E8	U-10ME2E8	U-12ME2E8	U-14ME2E8	U-16ME2E8	U-14ME2E8
			U-12ME2E8	U-12ME2E8	U-16ME2E8	U-16ME2E8	U-16ME2E8	U-16ME2E8	U-20ME2E8
Power supply	Voltage	V	380-400-415	380-400-415	380-400-415	380-400-415	380-400-415	380-400-415	380-400-415
	Phase		Three Phase	Three Phase	Three Phase	Three Phase	Three Phase	Three Phase	Three Phase
	Frequency	Hz	50	50	50	50	50	50	50
Cooling capacity		kW	61,5	68,0	73,0	78,5	85,0	90,0	96,0
EER <sup>1)</sup>		W/W	4,13	3,93	3,80	3,69	3,68	3,52	3,56
SEER <sup>2)</sup>			<b>6,90</b>	<b>6,86</b>	<b>6,62</b>	<b>6,60</b>	<b>6,88</b>	<b>6,55</b>	<b>7,21</b>
Running current cooling		A	23,10/22,30	26,60/25,60	30,10/29,00	33,10/31,90	36,60/35,30	40,20/38,70	41,90/40,40
Input power cooling		kW	14,90	17,30	19,20	21,30	23,10	25,60	27,00
Heating capacity		kW	69,0	76,5	81,5	87,5	95,0	100,0	108,0
COP <sup>1)</sup>		W/W	4,76	4,69	4,55	4,56	4,48	4,42	4,17
SCOP <sup>2)</sup>			<b>4,53</b>	<b>4,78</b>	<b>4,16</b>	<b>4,29</b>	<b>4,13</b>	<b>4,09</b>	<b>4,14</b>
Running current heating		A	22,70/21,90	25,30/24,40	28,40/27,40	30,10/29,00	33,60/32,40	35,80/34,60	40,60/39,20
Input power heating		kW	14,50	16,30	17,90	19,20	21,20	22,60	25,90
Starting current		A	2,00	2,00	3,00	3,00	4,00	4,00	4,00
External static pressure [Max]		Pa	80	80	80	80	80	80	80
Air volume		m <sup>3</sup> /min	456	464	456	464	464	464	637
Sound pressure	Normal / Silent mode	dB(A)	61,00/58,00	62,00/59,00	62,50/59,50	63,50/60,50	63,50/60,50	64,00/61,00	63,00/60,00
Sound power	Normal mode	dB(A)	82,00	83,00	83,50	84,50	84,50	85,00	84,00
Dimension / Net weight	H x W x D	mm / kg	1842 x 2010 x 1000/480	1842 x 2420 x 1000/540	1842 x 2010 x 1000/525	1842 x 2420 x 1000/585	1842 x 2420 x 1000/630	1842 x 2420 x 1000/630	1842 x 2780 x 1000/690
Piping connections <sup>3)</sup>	Liquid pipe	Inch (mm)	5/8(15,88)/3/4(19,05)	5/8(15,88)/3/4(19,05)	3/4(19,05)/7/8(22,22)	3/4(19,05)/7/8(22,22)	3/4(19,05)/7/8(22,22)	3/4(19,05)/7/8(22,22)	3/4(19,05)/7/8(22,22)
	Gas pipe	Inch (mm)	1-1/8(28,58)/1-1/4(31,75)	1-1/8(28,58)/1-1/4(31,75)	1-1/4(31,75)/1-1/2(38,10)	1-1/4(31,75)/1-1/2(38,10)	1-1/4(31,75)/1-1/2(38,10)	1-1/4(31,75)/1-1/2(38,10)	1-1/4(31,75)/1-1/2(38,10)
	Balance pipe	Inch (mm)	1/4(6,35)	1/4(6,35)	1/4(6,35)	1/4(6,35)	1/4(6,35)	1/4(6,35)	1/4(6,35)
Refrigerant (R410A) / CO <sub>2</sub> Eq.		kg / T	13,90/23,3856	16,60/34,6608	13,90/29,0232	16,60/34,6608	16,60/34,6608	16,60/34,6608	17,80/37,1664
Maximum allowable indoor / outdoor capacity ratio % <sup>4)</sup>			50 ~ 130(200)	50 ~ 130(200)	50 ~ 130(200)	50 ~ 130(200)	50 ~ 130(200)	50 ~ 130(200)	50 ~ 130(200)
Operating range	Cool Min ~ Max	°C	-10 ~ +52	-10 ~ +52	-10 ~ +52	-10 ~ +52	-10 ~ +52	-10 ~ +52	-10 ~ +52
	Heat Min ~ Max	°C	-25 ~ +18	-25 ~ +18	-25 ~ +18	-25 ~ +18	-25 ~ +18	-25 ~ +18	-25 ~ +18

2-Pipe ECOi EX ME2 Series Space Saving Model Combination from 36 to 48 HP

			36 HP	38 HP	40 HP	42 HP	44 HP	46 HP	48 HP
Model name			U-16ME2E8	U-18ME2E8	U-20ME2E8	U-10ME2E8	U-12ME2E8	U-14ME2E8	U-16ME2E8
			U-20ME2E8	U-20ME2E8	U-20ME2E8	U-16ME2E8	U-16ME2E8	U-16ME2E8	U-16ME2E8
Power supply	Voltage	V	380-400-415	380-400-415	380-400-415	380-400-415	380-400-415	380-400-415	380-400-415
	Phase		Three Phase	Three Phase	Three Phase	Three Phase	Three Phase	Three Phase	Three Phase
	Frequency	Hz	50	50	50	50	50	50	50
Cooling capacity		kW	101,0	107,0	113,0	118,0	124,0	130,0	135,0
EER <sup>1)</sup>		W/W	3,42	3,42	3,34	3,69	3,62	3,62	3,52
SEER <sup>2)</sup>			<b>6,86</b>	<b>7,32</b>	<b>7,16</b>	<b>6,57</b>	<b>6,6</b>	<b>6,7</b>	<b>6,55</b>
Running current cooling		A	45,30/43,70	48,10/46,30	51,40/49,50	50,20/48,40	53,20/51,30	56,90/54,90	60,20/58,10
Input power cooling		kW	25,9	31,3	33,8	32,0	34,3	35,9	38,4
Heating capacity		kW	113,0	119,0	127,0	132,0	138,0	145,0	150,0
COP <sup>1)</sup>		W/W	4,14	4,13	3,92	4,49	4,50	4,46	4,42
SCOP <sup>2)</sup>			<b>4,06</b>	<b>4,14</b>	<b>4,13</b>	<b>4,11</b>	<b>4,21</b>	<b>4,12</b>	<b>4,09</b>
Running current heating		A	42,40/40,80	44,70/43,10	49,80/48,00	46,60/44,90	48,20/46,40	51,50/49,70	53,80/51,80
Input power heating		kW	27,30	28,80	32,40	29,40	30,70	32,50	33,90
Starting current		A	4,00	4,00	4,00	5,00	5,00	6,00	6,00
External static pressure [Max]		Pa	80	80	80	80	80	80	80
Air volume		m <sup>3</sup> /min	637	810	810	688	696	696	696
Sound pressure	Normal / Silent mode	dB(A)	63,50/60,50	62,50/59,50	63,00/60,00	65,00/62,00	65,50/62,50	65,50/62,50	66,00/63,00
Sound power	Normal mode	dB(A)	84,50	83,50	84,00	86,00	86,50	86,50	87,00
Dimension / Net weight	H x W x D	mm / kg	1842 x 2780 x 1000/690	1842 x 3140 x 1000/750	1842 x 3140 x 1000/750	1842 x 3250 x 1000/840	1842 x 3660 x 1000/900	1842 x 3660 x 1000/945	1842 x 3660 x 1000/945
Piping connections <sup>3)</sup>	Liquid pipe	Inch (mm)	3/4(19,05)/7/8(22,22)	3/4(19,05)/7/8(22,22)	3/4(19,05)/7/8(22,22)	3/4(19,05)/7/8(22,22)	3/4(19,05)/7/8(22,22)	3/4(19,05)/7/8(22,22)	3/4(19,05)/7/8(22,22)
	Gas pipe	Inch (mm)	1-1/2(38,10)/1-5/8(41,28)	1-1/2(38,10)/1-5/8(41,28)	1-1/2(38,10)/1-5/8(41,28)	1-1/2(38,10)/1-5/8(41,28)	1-1/2(38,10)/1-5/8(41,28)	1-1/2(38,10)/1-5/8(41,28)	1-1/2(38,10)/1-5/8(41,28)
	Balance pipe	Inch (mm)	1/4(6,35)	1/4(6,35)	1/4(6,35)	1/4(6,35)	1/4(6,35)	1/4(6,35)	1/4(6,35)
Refrigerant (R410A) / CO <sub>2</sub> Eq.		kg / T	17,80/37,1664	19,00/39,672	19,00/39,672	22,20/46,3536	24,90/51,9912	24,90/51,9912	24,90/51,9912
Maximum allowable indoor / outdoor capacity ratio % <sup>4)</sup>			50 ~ 130(200)	50 ~ 130(200)	50 ~ 130(200)	50 ~ 130(200)	50 ~ 130(200)	50 ~ 130(200)	50 ~ 130(200)
Operating range	Cool Min ~ Max	°C	-10 ~ +52	-10 ~ +52	-10 ~ +52	-10 ~ +52	-10 ~ +52	-10 ~ +52	-10 ~ +52
	Heat Min ~ Max	°C	-25 ~ +18	-25 ~ +18	-25 ~ +18	-25 ~ +18	-25 ~ +18	-25 ~ +18	-25 ~ +18

1) EER and COP calculation is based in accordance to EN14511. 2) SEER/SCOP is calculated based on the seasonal space cooling/heating efficiency "η" values of the COMMISSION REGULATION (EU) 2016/2281. SEER, SCOP = (η + Correction) PEF. 3) Pipe diameter under 90 m for ultimate indoor unit / over 90 m for ultimate indoor unit (if the longest piping equivalent length exceeds 90 m, increase the sizes of the main tubes by 1 rank for gas tubes and liquid tubes). 4) If the following conditions are satisfied, the effective range is above 130 % and below 200 %: A. Obey the limited number of connectable indoor units. B. The lower limit of operating range for heating outdoor temperature is limited to -10 °C WB (standard -25 °C WB). C. Simultaneous operation is limited to less than 130 % of connectable indoor units.

## 2-Pipe ECOi EX ME2 Series Space Saving Model Combination from 50 to 64 HP

			50 HP	52 HP	54 HP	56 HP	58 HP	60 HP	62 HP	64 HP
Model name			U-14ME2E8	U-16ME2E8	U-14ME2E8	U-16ME2E8	U-18ME2E8	U-20ME2E8	U-14ME2E8	U-16ME2E8
			U-16ME2E8	U-16ME2E8	U-20ME2E8	U-20ME2E8	U-20ME2E8	U-20ME2E8	U-16ME2E8	U-16ME2E8
			U-20ME2E8	U-20ME2E8	U-20ME2E8	U-20ME2E8	U-20ME2E8	U-20ME2E8	U-16ME2E8	U-16ME2E8
									U-16ME2E8	U-16ME2E8
Power supply	Voltage	V	380-400-415	380-400-415	380-400-415	380-400-415	380-400-415	380-400-415	380-400-415	380-400-415
	Phase		Three Phase	Three Phase	Three Phase	Three Phase	Three Phase	Three Phase	Three Phase	Three Phase
	Frequency	Hz	50	50	50	50	50	50	50	50
Cooling capacity	kW		140,0	145,0	151,0	156,0	162,0	168,0	174,0	180,0
EER <sup>1)</sup>	W/W		3,55	3,46	3,49	3,41	3,40	3,35	3,60	3,52
SEER <sup>2)</sup>			<b>6,96</b>	<b>6,72</b>	<b>7,16</b>	<b>6,92</b>	<b>7,3</b>	<b>7,16</b>	<b>6,68</b>	<b>6,55</b>
Running current cooling	A		61,10/58,90	65,00/62,70	66,50/64,10	70,30/67,80	73,10/70,40	76,10/73,40	75,80/73,00	80,30/77,40
Input power cooling	kW		39,40	41,90	43,30	45,80	47,60	50,10	48,30	51,20
Heating capacity	kW		155,0	160,0	169,0	175,0	182,0	189,0	195,0	201,0
COP <sup>1)</sup>	W/W		4,29	4,27	4,11	4,08	4,06	3,94	4,45	4,42
SCOP <sup>2)</sup>			<b>4,08</b>	<b>4,05</b>	<b>4,13</b>	<b>4,07</b>	<b>4,13</b>	<b>4,13</b>	<b>4,11</b>	<b>4,09</b>
Running current heating	A		56,60/54,60	58,80/56,70	63,80/61,50	66,60/64,20	69,50/67,00	73,70/71,00	69,50/67,00	72,20/69,60
Input power heating	kW		36,10	37,50	41,10	42,90	44,80	48,00	43,80	45,50
Starting current	A		6,00	6,00	6,00	6,00	6,00	6,00	8,00	8,00
External static pressure (Max)	Pa		80	80	80	80	80	80	80	80
Air volume	m <sup>3</sup> /min		869	869	1042	1042	1215	1215	928	928
Sound pressure	Normal / Silent mode	dB(A)	65,50/62,50	65,50/62,50	65,00/62,00	65,50/62,50	64,50/61,50	65,00/62,00	67,00/64,00	67,00/64,00
Sound power	Normal mode	dB(A)	86,50	86,50	86,00	86,50	85,50	86,00	88,00	88,00
Dimension / Net weight	HxWxD	mm / kg	1842x4020x1000/1005	1842x4020x1000/1005	1842x4380x1000/1065	1842x4380x1000/1065	1842x4740x1000/1125	1842x4740x1000/1125	1842x4900x1000/1260	1842x4900x1000/1260
Piping connections <sup>3)</sup>	Liquid pipe	Inch (mm)	3/4(19,05)/7/8(22,22)	3/4(19,05)/7/8(22,22)	3/4(19,05)/7/8(22,22)	3/4(19,05)/7/8(22,22)	3/4(19,05)/7/8(22,22)	3/4(19,05)/7/8(22,22)	3/4(19,05)/7/8(22,22)	3/4(19,05)/7/8(22,22)
	Gas pipe	Inch (mm)	1-1/2(38,10)/1-5/8(41,28)	1-1/2(38,10)/1-5/8(41,28)	1-1/2(38,10)/1-5/8(41,28)	1-1/2(38,10)/1-5/8(41,28)	1-1/2(38,10)/1-5/8(41,28)	1-1/2(38,10)/1-5/8(41,28)	1-5/8(41,28)/1-3/4(44,45)	1-5/8(41,28)/1-3/4(44,45)
	Balance pipe	Inch (mm)	1/4(6,35)	1/4(6,35)	1/4(6,35)	1/4(6,35)	1/4(6,35)	1/4(6,35)	1/4(6,35)	1/4(6,35)
Refrigerant (R410A) / CO <sub>2</sub> Eq.	kg / T		26,10/54,4968	26,10/54,4968	27,30/57,0024	27,30/57,0024	28,50/59,508	28,50/59,508	33,20/69,3216	33,20/69,3216
Maximum allowable indoor / outdoor capacity ratio % <sup>4)</sup>			50 ~ 130(200)	50 ~ 130(200)	50 ~ 130(200)	50 ~ 130(200)	50 ~ 130(200)	50 ~ 130(200)	50 ~ 130(200)	50 ~ 130(200)
Operating range	Cool Min ~ Max	°C	-10 ~ +52	-10 ~ +52	-10 ~ +52	-10 ~ +52	-10 ~ +52	-10 ~ +52	-10 ~ +52	-10 ~ +52
	Heat Min ~ Max	°C	-25 ~ +18	-25 ~ +18	-25 ~ +18	-25 ~ +18	-25 ~ +18	-25 ~ +18	-25 ~ +18	-25 ~ +18

## 2-Pipe ECOi EX ME2 Series Space Saving Model Combination from 66 to 80 HP

			66 HP	68 HP	70 HP	72 HP	74 HP	76 HP	78 HP	80 HP	
Model name			U-10ME2E8	U-12ME2E8	U-10ME2E8	U-16ME2E8	U-16ME2E8	U-16ME2E8	U-18ME2E8	U-20ME2E8	U-20ME2E8
			U-16ME2E8	U-16ME2E8	U-20ME2E8	U-16ME2E8	U-18ME2E8	U-20ME2E8	U-20ME2E8	U-20ME2E8	U-20ME2E8
			U-20ME2E8	U-20ME2E8	U-20ME2E8	U-20ME2E8	U-20ME2E8	U-20ME2E8	U-20ME2E8	U-20ME2E8	U-20ME2E8
			U-20ME2E8	U-20ME2E8	U-20ME2E8	U-20ME2E8	U-20ME2E8	U-20ME2E8	U-20ME2E8	U-20ME2E8	U-20ME2E8
Power supply	Voltage	V	380-400-415	380-400-415	380-400-415	380-400-415	380-400-415	380-400-415	380-400-415	380-400-415	
	Phase		Three Phase	Three Phase	Three Phase	Three Phase	Three Phase	Three Phase	Three Phase	Three Phase	
	Frequency	Hz	50	50	50	50	50	50	50	50	
Cooling capacity	kW		185,0	190,0	196,0	202,0	208,0	213,0	219,0	224,0	
EER <sup>1)</sup>	W/W		3,52	3,49	3,47	3,42	3,42	3,39	3,38	3,35	
SEER <sup>2)</sup>			<b>6,92</b>	<b>6,91</b>	<b>7,09</b>	<b>6,86</b>	<b>7,03</b>	<b>7,01</b>	<b>7,18</b>	<b>7,16</b>	
Running current cooling	A		80,80/77,80	83,70/80,70	86,80/83,60	90,60/87,30	93,40/90,00	96,60/93,10	98,30/94,70	101,50/97,80	
Input power cooling	kW		52,60	54,50	56,50	59,00	60,80	62,90	64,70	66,80	
Heating capacity	kW		207,0	213,0	219,0	226,0	233,0	239,0	245,0	252,0	
COP <sup>1)</sup>	W/W		4,16	4,18	4,05	4,14	4,12	4,03	4,03	3,94	
SCOP <sup>2)</sup>			<b>4,11</b>	<b>4,17</b>	<b>4,13</b>	<b>4,06</b>	<b>4,12</b>	<b>4,07</b>	<b>4,13</b>	<b>4,13</b>	
Running current heating	A		77,10/74,30	79,20/76,30	83,10/80,10	84,70/81,70	87,70/84,50	92,00/88,70	93,40/90,00	98,30/94,70	
Input power heating	kW		49,70	51,00	54,10	54,60	56,50	59,30	60,80	64,00	
Starting current	A		7,00	7,00	7,00	8,00	8,00	8,00	8,00	8,00	
External static pressure (Max)	Pa		80	80	80	80	80	80	80	80	
Air volume	m <sup>3</sup> /min		1266	1274	1439	1274	1447	1447	1620	1620	
Sound pressure	Normal / Silent mode	dB(A)	66,00/63,00	66,50/63,50	65,50/62,50	66,50/63,50	66,50/63,50	66,50/63,50	66,00/63,00	66,00/63,00	
Sound power	Normal mode	dB(A)	87,00	87,50	86,50	87,50	87,50	87,50	87,00	87,00	
Dimension / Net weight	HxWxD	mm / kg	1842x5210x1000/1275	1842x5620x1000/1335	1842x5570x1000/1335	1842x5620x1000/1380	1842x5980x1000/1440	1842x5980x1000/1440	1842x6340x1000/1500	1842x6340x1000/1500	
Piping connections <sup>3)</sup>	Liquid pipe	Inch (mm)	3/4(19,05)/7/8(22,22)	7/8(22,22)/1(25,04)	7/8(22,22)/1(25,04)	7/8(22,22)/1(25,04)	7/8(22,22)/1(25,04)	7/8(22,22)/1(25,04)	7/8(22,22)/1(25,04)	7/8(22,22)/1(25,04)	
	Gas pipe	Inch (mm)	1-5/8(41,28)/1-3/4(44,45)	1-5/8(41,28)/1-3/4(44,45)	1-5/8(41,28)/1-3/4(44,45)	1-3/4(44,45)/2(50,80)	1-3/4(44,45)/2(50,80)	1-3/4(44,45)/2(50,80)	1-3/4(44,45)/2(50,80)	1-3/4(44,45)/2(50,80)	
	Balance pipe	Inch (mm)	1/4(6,35)	1/4(6,35)	1/4(6,35)	1/4(6,35)	1/4(6,35)	1/4(6,35)	1/4(6,35)	1/4(6,35)	
Refrigerant (R410A) / CO <sub>2</sub> Eq.	kg / T		32,90/68,6952	35,60/74,3328	34,10/19,836	35,80/68,6952	36,80/76,8384	36,80/76,8384	38,00/79,344	38,00/79,344	
Maximum allowable indoor / outdoor capacity ratio % <sup>4)</sup>			50 ~ 130(200)	50 ~ 130(200)	50 ~ 130(200)	50 ~ 130(200)	50 ~ 130(200)	50 ~ 130(200)	50 ~ 130(200)	50 ~ 130(200)	
Operating range	Cool Min ~ Max	°C	-10 ~ +52	-10 ~ +52	-10 ~ +52	-10 ~ +52	-10 ~ +52	-10 ~ +52	-10 ~ +52	-10 ~ +52	
	Heat Min ~ Max	°C	-25 ~ +18	-25 ~ +18	-25 ~ +18	-25 ~ +18	-25 ~ +18	-25 ~ +18	-25 ~ +18	-25 ~ +18	

1) EER and COP calculation is based in accordance to EN14511. 2) SEER/SCOP is calculated based on the seasonal space cooling/heating efficiency "η" values of the COMMISSION REGULATION (EU) 2016/2281. SEER, SCOP = [η + Correction] PEf. 3) Pipe diameter under 90 m for ultimate indoor unit / over 90 m for ultimate indoor unit (if the longest piping equivalent length exceeds 90 m, increase the sizes of the main tubes by 1 rank for gas tubes and liquid tubes). 4) If the following conditions are satisfied, the effective range is above 130 % and below 200 %: A. Obey the limited number of connectable indoor units. B. The lower limit of operating range for heating outdoor temperature is limited to -10 °C WB (standard -25 °C WB). C. Simultaneous operation is limited to less than 130 % of connectable indoor units.

# 3-Pipe ECOi EX MF3 Series



Simultaneous heating and cooling VRF system.  
The Panasonic 3-Pipe MF3 Series offers the best solution for the most demanding customers.



## Simultaneous heating and cooling VRF System

The Panasonic 3-Pipe ECOi EX MF3 series offers the ideal solution to meet customer's demand.

### Upgraded energy efficiency utilized ECOi EX technology.

- SEER / SCOP improved in full capacities from 8 to 16 HP
- SEER / SCOP follows LOT21 from started from January 2018
- EER / COP is certified in Eurovent

### Design flexibility.

- High reliability even under tough temperature condition
- Maximum 52 indoor units connectable
- Slim heat recovery box with just 200 mm height
- Farthest piping length between indoor units and outdoor units: 200 m

### Excellent seasonal energy saving.

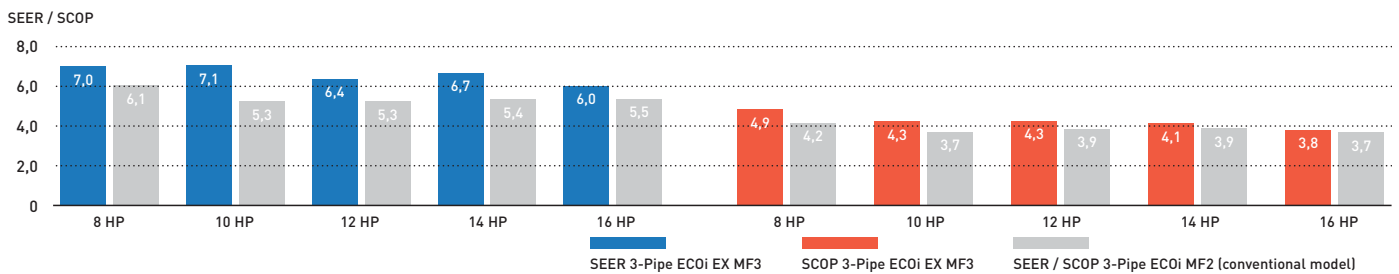

## Extended design operation conditions

Cooling design operation conditions: The cooling operation range has been extended to -10 °C ~ 52 °C by changing the outdoor fan to an Inverter type.

Heating design operation conditions: Stable heating operation even with an outside air temperature of -20 °C. The heating operation range has been extended to -20 °C by use of a compressor with a high-pressure vessel.

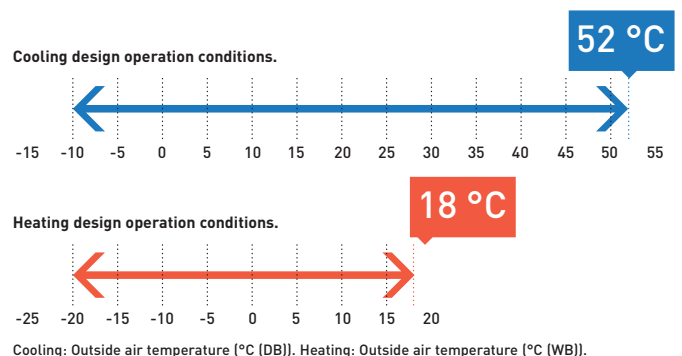

## Wide temperature setting range

Wired remote controller heating temperature setting range is 16 to 30 °C.



**4,9  
SCOP**

### 3-Pipe ECOi EX MF3 Series

			8 HP	10 HP	12 HP	14 HP	16 HP
Outdoor units			U-8MF3E8	U-10MF3E8	U-12MF3E8	U-14MF3E8	U-16MF3E8
Power supply	Voltage	V	380 - 400 - 415	380 - 400 - 415	380 - 400 - 415	380 - 400 - 415	380 - 400 - 415
	Phase		Three Phase	Three Phase	Three Phase	Three Phase	Three Phase
	Frequency	Hz	50	50	50	50	50
Cooling capacity		kW	22,4	28,0	33,5	40,0	45,0
EER <sup>1)</sup>		W/W	5,11	4,72	3,91	3,70	3,49
SEER <sup>2)</sup>			<b>7,0</b>	<b>7,1</b>	<b>6,4</b>	<b>6,7</b>	<b>6,0</b>
Running current cooling		A	7,16 / 6,80 / 6,55	9,90 / 9,41 / 9,07	3,19 / 13,20 / 12,70	18,20 / 17,30 / 16,70	21,30 / 20,20 / 19,50
Input power cooling		kW	4,38	5,93	8,57	10,80	12,90
Heating capacity		kW	25,0	31,5	37,5	45,0	50,0
COP <sup>1)</sup>		W/W	5,25	5,17	4,51	4,21	4,17
SCOP <sup>2)</sup>			<b>4,9</b>	<b>4,3</b>	<b>4,3</b>	<b>4,1</b>	<b>3,8</b>
Running current heating		A	7,78 / 7,39 / 7,12	10,20 / 9,66 / 9,31	13,40 / 12,80 / 12,30	18,10 / 17,20 / 16,50	20,00 / 19,00 / 18,30
Input power heating		kW	4,76	6,09	8,32	10,70	12,00
Starting current		A	1,00	1,00	1,00	2,00	2,00
External static pressure (Max)		Pa	80	80	80	80	80
Air volume		m <sup>3</sup> /min	210	220	232	232	232
Sound pressure	Normal mode	dB(A)	54,00	57,00	60,00	61,00	62,00
	Silent mode 1 / 2	dB(A)	51,00 / 49,00	54,00 / 52,00	57,00 / 55,00	58,00 / 56,00	59,00 / 57,00
Sound power	Normal mode	dB(A)	76,00	78,00	81,00	82,00	82,00
Dimension	H x W x D	mm	1842 x 1180 x 1000	1842 x 1180 x 1000	1842 x 1180 x 1000	1842 x 1180 x 1000	1842 x 1180 x 1000
Net weight		kg	261	262	286	334	334
Piping connections <sup>3)</sup>	Liquid pipe	Inch (mm)	3/8 (9,52) / 1/2 (12,70)	3/8 (9,52) / 1/2 (12,70)	1/2 (12,70) / 5/8 (15,88)	1/2 (12,70) / 5/8 (15,88)	1/2 (12,70) / 5/8 (15,88)
	Discharge pipe	Inch (mm)	5/8 (15,88) / 3/4 (19,05)	3/4 (19,05) / 7/8 (22,22)	3/4 (19,05) / 7/8 (22,22)	7/8 (22,22) / 1 (25,40)	7/8 (22,22) / 1 (25,40)
	Suction pipe	Inch (mm)	3/4 (19,05) / 7/8 (22,22)	7/8 (22,22) / 1 (25,40)	1 (25,40) / 1-1/8 (28,58)	1 (25,40) / 1-1/8 (28,58)	1-1/8 (28,58) / 1-1/4 (31,75)
	Balance pipe	Inch (mm)	1/4 (6,35)	1/4 (6,35)	1/4 (6,35)	1/4 (6,35)	1/4 (6,35)
Refrigerant (R410A) / CO <sub>2</sub> Eq.		kg / T	6,80 / 14,1984	6,80 / 14,1984	8,30 / 17,3304	8,30 / 17,3304	8,30 / 17,3304
Maximum allowable indoor / outdoor capacity ratio %			50 ~ 150	50 ~ 150	50 ~ 150	50 ~ 150	50 ~ 150
	Cool Min ~ Max	°C	-10 ~ +52	-10 ~ +52	-10 ~ +52	-10 ~ +52	-10 ~ +52
	Heat Min ~ Max	°C	-20 ~ +18	-20 ~ +18	-20 ~ +18	-20 ~ +18	-20 ~ +18
Operating range	Simultaneous op.	°C	-10 ~ +24	-10 ~ +24	-10 ~ +24	-10 ~ +24	-10 ~ +24

#### Solenoid valve kit

	<b>KIT-P56HR3</b>	3-Pipe control Solenoid valve kit (up to 5,6 kW)
<b>KIT-P56HR3</b>	<b>CZ-P56HR3</b>	Solenoid valve kit (up to 5,6 kW)
	<b>CZ-CAPE2</b>	3-Pipe control PCB
	<b>KIT-P160HR3</b>	3-Pipe control Solenoid valve kit (from 5,60 to 16,0 kW)
<b>KIT-P160HR3</b>	<b>CZ-P160HR3</b>	Solenoid valve kit (from 5,6 kW to 16,0 kW)
	<b>CZ-CAPE2</b>	3-Pipe control PCB
<b>CZ-CAPEK2 <sup>4)</sup></b>		3-Pipe control PCB for Wall-mounted

#### 3-Pipe control box kit

	<b>CZ-P456HR3</b>	4 ports 3 pipe box (up to 5,6 kW per port)
	<b>CZ-P656HR3</b>	6 ports 3 pipe box (up to 5,6 kW per port)
	<b>CZ-P856HR3</b>	8 ports 3 pipe box (up to 5,6 kW per port)
	<b>CZ-P4160HR3</b>	4 ports 3 pipe box (up to 16,0 kW per port)

1) EER and COP calculation is based in accordance to EN14511. 2) SEER/SCOP is calculated based on the seasonal space cooling/heating efficiency "η" values of the COMMISSION REGULATION (EU) 2016/2281. SEER, SCOP = (η + Correction) x PEF. 3) Pipe diameter under 90 m for ultimate indoor unit / over 90 m for ultimate indoor unit (if the longest piping equivalent length exceeds 90 m, increase the sizes of the main tubes by 1 rank for gas tubes and liquid tubes). 4) Available for S-45/56/73/106MK2E5A.



# Slim 3-Pipe Control Box Kit / Multiple connection type

Heat Recovery Box to connect multiple indoor units with just one box, 4, 6 and up to 8 indoor units or groups.



The height is only 200 mm. This is good advantage specially in hotel applications, where space for connecting several boxes is limited.

## Individual control of multiple indoor units with solenoid valve kits.

- Any design and layout can be used in a single system.
- Cooling operation is possible up to an outdoor temperature of -10 °C.

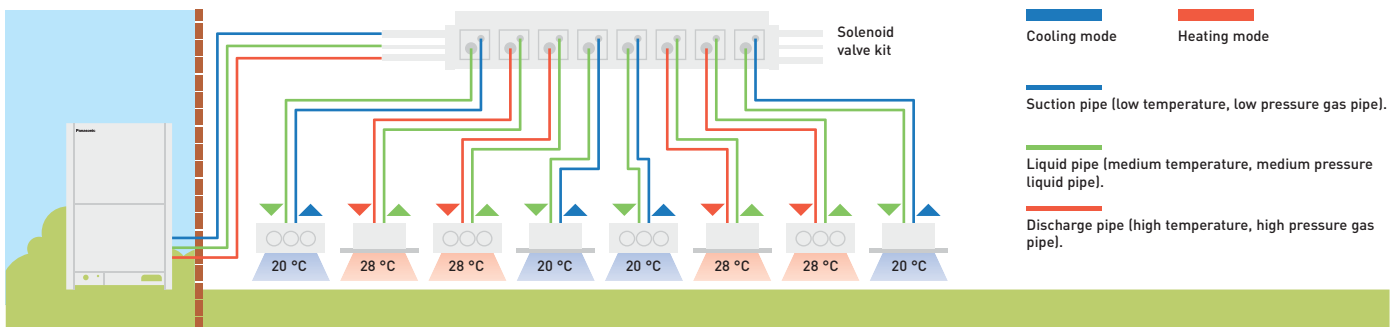
System structure.

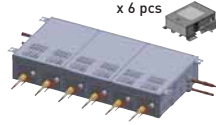
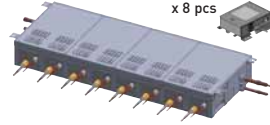

				
	1 port	4 port	6 port	8 port
56 type	CZ-P56HR3	CZ-P456HR3	CZ-P656HR3	CZ-P856HR3
160 type	CZ-P160HR3	CZ-P4160HR3	—	—

## Solenoid valve kit / wiring work

### Current model / single connection type.

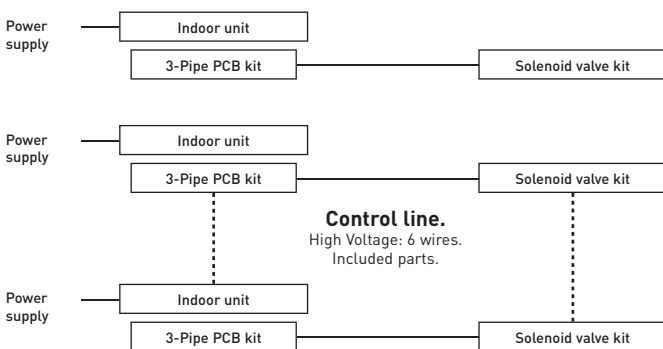

### New model / multiple connection type.

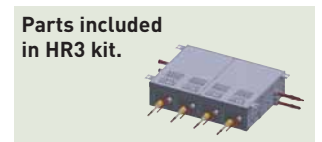
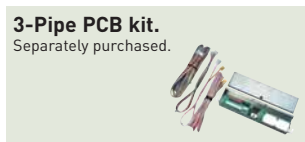
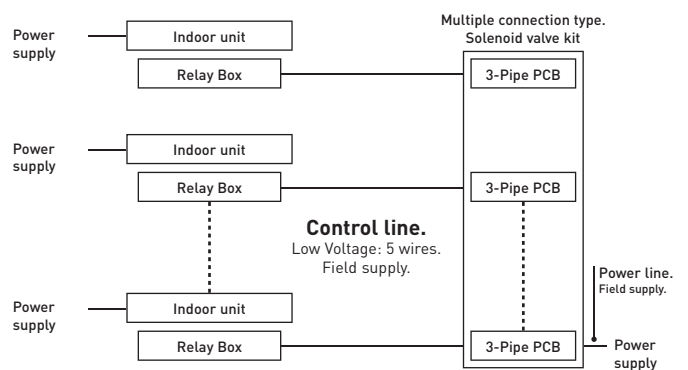

## 3-Pipe ECOi EX MF3 Series Combination from 18 to 32 HP

HP			18 HP	20 HP	22 HP	24 HP	26 HP	28 HP	30 HP	32 HP
Model name			U-8MF3E8 U-10MF3E8	U-8MF3E8 U-12MF3E8	U-10MF3E8 U-12MF3E8	U-12MF3E8 U-12MF3E8	U-10MF3E8 U-16MF3E8	U-12MF3E8 U-16MF3E8	U-14MF3E8 U-16MF3E8	U-16MF3E8 U-16MF3E8
	Power supply	Voltage	V	380 - 400 - 415	380 - 400 - 415	380 - 400 - 415	380 - 400 - 415	380 - 400 - 415	380 - 400 - 415	380 - 400 - 415
	Phase		Three Phase	Three Phase	Three Phase	Three Phase	Three Phase	Three Phase	Three Phase	Three Phase
	Frequency	Hz	50	50	50	50	50	50	50	50
Cooling capacity	kW		50,0	56,0	61,5	68,0	73,0	78,5	85,0	90,0
EER <sup>1)</sup>	W/W		4,90	4,31	4,24	3,89	3,88	3,65	3,59	3,49
Running current cooling	A		16,80/16,00/15,40	21,00/20,00/19,20	23,70/22,50/21,70	28,30/26,90/25,90	31,00/29,50/28,40	35,10/33,40/32,20	39,60/37,60/36,20	42,60/40,50/39,00
Input power cooling	kW		10,20	13,00	14,50	17,50	18,80	21,50	23,70	25,8
Heating capacity	kW		56,0	63,0	69,0	76,5	81,5	87,5	95,0	100,0
COP <sup>1)</sup>	W/W		5,23	4,77	4,79	4,47	4,50	4,31	4,19	4,17
Running current heating	A		17,70/16,80/16,20	21,30/20,30/19,50	23,50/22,30/21,50	27,60/26,30/25,30	30,20/28,70/27,70	33,50/31,80/30,70	37,90/36,00/34,70	40,10/38,10/36,70
Input power heating	kW		10,70	13,20	14,40	17,10	18,10	20,30	22,70	24,00
Starting current	A		2,00	2,00	2,00	2,00	3,00	3,00	4,00	4,00
External static pressure (Max)	Pa		80	80	80	80	80	80	80	80
Air volume	m <sup>3</sup> /min		430	442	452	464	452	464	464	464
Sound pressure	Normal mode	dB(A)	59,00	61,00	62,00	63,00	63,50	64,50	64,50	65,00
	Silent mode 1 / 2	dB(A)	56,00/54,00	58,00/56,00	59,00/57,00	60,00/58,00	60,50/58,50	61,50/59,50	61,50/59,50	62,00/60,00
Sound power	Normal mode	dB(A)	81,50	84,00	84,50	86,00	84,50	86,00	86,00	86,00
Dimension	H x W x D	mm	1842 x 2360 (+60) x 1000	1842 x 2360 (+60) x 1000	1842 x 2360 (+60) x 1000	1842 x 2360 (+60) x 1000	1842 x 2360 (+60) x 1000	1842 x 2360 (+60) x 1000	1842 x 2360 (+60) x 1000	1842 x 2360 (+60) x 1000
Net weight	kg		523	547	548	574	596	620	668	668
Piping connections <sup>2)</sup>	Liquid pipe	Inch (mm)	5/8(15,88)/ 3/4(19,05)	5/8(15,88)/ 3/4(19,05)	5/8(15,88)/ 3/4(19,05)	5/8(15,88)/ 3/4(19,05)	3/4(19,05)/ 7/8(22,22)	3/4(19,05)/ 7/8(22,22)	3/4(19,05)/ 7/8(22,22)	3/4(19,05)/ 7/8(22,22)
	Discharge pipe	Inch (mm)	7/8(22,22)/ 1(25,40)	7/8(22,22)/ 1(25,40)	1(25,40)/ 1-1/8(28,58)	1(25,40)/ 1-1/8(28,58)	1(25,40)/ 1-1/8(28,58)	1-1/8(28,58)/ 1-1/4(31,75)	1-1/8(28,58)/ 1-1/4(31,75)	1-1/8(28,58)/ 1-1/4(31,75)
	Suction pipe	Inch (mm)	1-1/8(28,58)/ 1-1/4(31,75)	1-1/8(28,58)/ 1-1/4(31,75)	1-1/8(28,58)/ 1-1/4(31,75)	1-1/8(28,58)/ 1-1/4(31,75)	1-1/4(31,75)/ 1-1/2(38,10)	1-1/4(31,75)/ 1-1/2(38,10)	1-1/4(31,75)/ 1-1/2(38,10)	1-1/4(31,75)/ 1-1/2(38,10)
	Balance pipe	Inch (mm)	1/4(6,35)	1/4(6,35)	1/4(6,35)	1/4(6,35)	1/4(6,35)	1/4(6,35)	1/4(6,35)	1/4(6,35)
Refrigerant (R410A) / CO <sub>2</sub> Eq.	kg / T		13,60/28,3968	15,10/31,5288	15,10/31,5288	16,60/34,6608	15,10/31,5288	16,60/34,6608	16,60/34,6608	16,60/34,6608
Maximum allowable indoor / outdoor capacity ratio %			50 ~ 150	50 ~ 150	50 ~ 150	50 ~ 150	50 ~ 150	50 ~ 150	50 ~ 150	50 ~ 150
Operating range	Cool Min ~ Max	°C	-10 ~ +52	-10 ~ +52	-10 ~ +52	-10 ~ +52	-10 ~ +52	-10 ~ +52	-10 ~ +52	-10 ~ +52
	Heat Min ~ Max	°C	-20 ~ +18	-20 ~ +18	-20 ~ +18	-20 ~ +18	-20 ~ +18	-20 ~ +18	-20 ~ +18	-20 ~ +18
	Simultaneous op.	°C	-10 ~ +24	-10 ~ +24	-10 ~ +24	-10 ~ +24	-10 ~ +24	-10 ~ +24	-10 ~ +24	-10 ~ +24

## 3-Pipe ECOi EX MF3 Series Combination from 34 to 48 HP

HP			34 HP	36 HP	38 HP	40 HP	42 HP	44 HP	46 HP	48 HP	
Model name			U-8MF3E8 U-10MF3E8 U-16MF3E8	U-8MF3E8 U-12MF3E8 U-16MF3E8	U-10MF3E8 U-12MF3E8 U-16MF3E8	U-8MF3E8 U-12MF3E8 U-16MF3E8	U-10MF3E8 U-16MF3E8 U-16MF3E8	U-12MF3E8 U-16MF3E8 U-16MF3E8	U-14MF3E8 U-16MF3E8 U-16MF3E8	U-16MF3E8 U-16MF3E8 U-16MF3E8	
	Power supply	Voltage	V	380 - 400 - 415	380 - 400 - 415	380 - 400 - 415	380 - 400 - 415	380 - 400 - 415	380 - 400 - 415	380 - 400 - 415	380 - 400 - 415
		Phase		Three Phase	Three Phase	Three Phase	Three Phase	Three Phase	Three Phase	Three Phase	Three Phase
	Frequency	Hz	50	50	50	50	50	50	50	50	
Cooling capacity	kW		96,0	101,0	107,0	113,0	118,0	124,0	130,0	135,0	
EER <sup>1)</sup>	W/W		4,10	3,90	3,88	3,72	3,72	3,58	3,55	3,49	
Running current cooling	A		38,60/36,70/35,40	42,30/40,20/38,70	45,60/43,30/41,70	50,20/47,70/46,00	52,40/49,70/47,90	56,50/53,70/51,80	61,10/58,10/56,00	63,90/60,70/58,50	
Input power cooling	kW		23,40	25,90	27,60	30,40	31,70	34,60	36,60	38,70	
Heating capacity	kW		108,0	113,0	119,0	127,0	132,0	138,0	145,0	150,0	
COP <sup>1)</sup>	W/W		4,64	4,48	4,51	4,31	4,36	4,25	4,18	4,17	
Running current heating	A		38,90/37,00/35,60	41,60/39,50/38,10	43,60/41,40/39,90	49,30/46,80/45,10	50,60/48,10/46,30	53,70/51,00/49,10	57,90/55,00/53,00	60,10/57,10/55,00	
Input power heating	kW		23,30	25,20	26,40	29,50	30,30	32,50	34,70	36,00	
Starting current	A		4,00	4,00	4,00	5,00	5,00	5,00	6,00	6,00	
External static pressure (Max)	Pa		80	80	80	80	80	80	80	80	
Air volume	m <sup>3</sup> /min		662	674	684	674	684	696	696	696	
Sound pressure	Normal mode	dB(A)	64,00	64,50	65,00	65,50	66,00	66,50	66,50	67,00	
	Silent mode 1 / 2	dB(A)	61,00/59,00	61,50/59,50	62,00/60,00	62,50/60,50	63,00/61,00	63,50/61,50	63,50/61,50	64,00/62,00	
Sound power	Normal mode	dB(A)	84,50	85,50	85,50	85,50	86,00	86,50	87,00	87,00	
Dimension	H x W x D	mm	1842 x 3540 (+120) x 1000	1842 x 3540 (+120) x 1000	1842 x 3540 (+120) x 1000	1842 x 3540 (+120) x 1000	1842 x 3540 (+120) x 1000	1842 x 3540 (+120) x 1000	1842 x 3540 (+120) x 1000	1842 x 3540 (+120) x 1000	
Net weight	kg		857	881	882	929	930	954	1002	1002	
Piping connections <sup>2)</sup>	Liquid pipe	Inch (mm)	3/4(19,05)/ 7/8(22,22)	3/4(19,05)/ 7/8(22,22)	3/4(19,05)/ 7/8(22,22)	3/4(19,05)/ 7/8(22,22)	3/4(19,05)/ 7/8(22,22)	3/4(19,05)/ 7/8(22,22)	3/4(19,05)/ 7/8(22,22)	3/4(19,05)/ 7/8(22,22)	
	Discharge pipe	Inch (mm)	1-1/8(28,58)/ 1-1/4(31,75)	1-1/8(28,58)/ 1-1/4(31,75)	1-1/4(31,75)/ 1-1/2(38,10)	1-1/4(31,75)/ 1-1/2(38,10)	1-1/4(31,75)/ 1-1/2(38,10)	1-1/4(31,75)/ 1-1/2(38,10)	1-1/4(31,75)/ 1-1/2(38,10)	1-1/4(31,75)/ 1-1/2(38,10)	
	Suction pipe	Inch (mm)	1-1/4(31,75)/ 1-1/2(38,10)	1-1/2(38,10)/ 1-5/8(41,28)	1-1/2(38,10)/ 1-5/8(41,28)	1-1/2(38,10)/ 1-5/8(41,28)	1-1/2(38,10)/ 1-5/8(41,28)	1-1/2(38,10)/ 1-5/8(41,28)	1-1/2(38,10)/ 1-5/8(41,28)	1-1/2(38,10)/ 1-5/8(41,28)	
	Balance pipe	Inch (mm)	1/4(6,35)	1/4(6,35)	1/4(6,35)	1/4(6,35)	1/4(6,35)	1/4(6,35)	1/4(6,35)	1/4(6,35)	
Refrigerant (R410A) / CO <sub>2</sub> Eq.	kg / T		21,90/45,72719	23,40/48,85919	23,40/48,85919	23,40/48,85919	23,40/48,85919	24,90/46,3536	24,90/51,9912	24,90/51,9912	
Maximum allowable indoor / outdoor capacity ratio %			50 ~ 150	50 ~ 150	50 ~ 150	50 ~ 150	50 ~ 150	50 ~ 150	50 ~ 150	50 ~ 150	
Operating range	Cool Min ~ Max	°C	-10 ~ +52	-10 ~ +52	-10 ~ +52	-10 ~ +52	-10 ~ +52	-10 ~ +52	-10 ~ +52	-10 ~ +52	
	Heat Min ~ Max	°C	-20 ~ +18	-20 ~ +18	-20 ~ +18	-20 ~ +18	-20 ~ +18	-20 ~ +18	-20 ~ +18	-20 ~ +18	
	Simultaneous op.	°C	-10 ~ +24	-10 ~ +24	-10 ~ +24	-10 ~ +24	-10 ~ +24	-10 ~ +24	-10 ~ +24	-10 ~ +24	

1) EER and COP calculation is based in accordance to EN14511. 2) Pipe diameter under 90 m for ultimate indoor unit / over 90 m for ultimate indoor unit (if the longest piping equivalent length exceeds 90 m, increase the sizes of the main tubes by 1 rank for gas tubes and liquid tubes).

# Water Heat Exchanger for hydronic applications



## ECOi Water Heat Exchanger

Electrical VRF with Water Heat Exchanger

With this easy to install Water Heat Exchanger unit, you can now cover projects up to 51 kW hot water demand or 44 kW on chilled application on a efficient way and cost effective

System example.

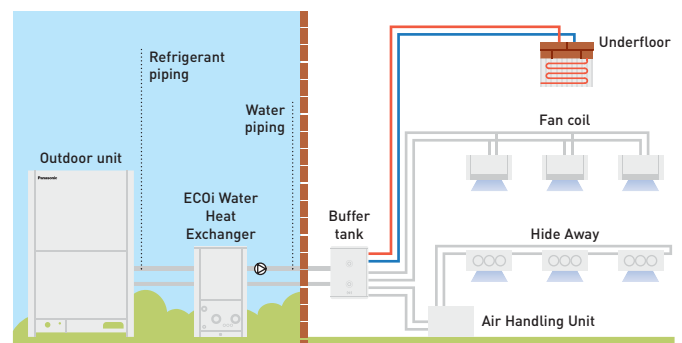

A buffer tank of minimum 280l for 28 kW and 500l for 50 kW is always needed.





### ECOi 2-Pipe with Water Heat Exchanger for chilled and hot water production

Hydrokit with A class water pump		PAW-250WP5G1	PAW-500WP5G1
Hydrokit without pump		PAW-250W5G1	PAW-500W5G1
Cooling capacity at 35 °C, water outlet 7 °C	kW	25,0	50,0
Heating capacity	kW	28,0	56,0
Heating capacity at +7 °C, heating water temperature at 45 °C	kW	28,0	56,0
COP at +7 °C with heating water temperature at 45 °C	W/W	2,97	3,10
<b>Heating Energy Efficiency class at 35 °C <sup>1)</sup></b>		<b>A++</b>	<b>A++</b>
$\eta_{sh}$ (LOT1) <sup>2)</sup>	%	<b>152,00</b>	<b>152,00</b>
Dimension	HxWxD	mm	1000 x 575 x 1110
Net weight		kg	135 (140 with pump)
Water pipe connector			Rp2 Female Thread (50A)
Heating water flow ( $\Delta T=5$ K, 35 °C)		m <sup>3</sup> /h	5,16
Capacity of integrated electric heater		kW	Not equipped
Flow switch			Equipped
Water filter			Equipped
Input power	kW	0,329 (with A class water pump) / 0,024 (without pump)	0,574 (with A class water pump) / 0,024 (without pump)
Maximum current	A	1,43 (with A class water pump) / 0,10 (without pump)	2,50 (with A class water pump) / 0,10 (without pump)
<b>Outdoor unit</b>		<b>U-10ME2E8</b>	<b>U-20ME2E8</b>
Sound pressure		dB(A)	56
Dimension	HxWxD	mm	1842 x 770 x 1000
Net weight		kg	210
Piping connections	Liquid pipe	Inch (mm)	3/8 (9,52)
	Gas pipe	Inch (mm)	7/8 (22,22)
Refrigerant (R410A) / CO <sub>2</sub> Eq.	kg	5,6 *Need Additional gas amount at site	9,5 *Need Additional gas amount at site
Pipe length range / Elevation difference (in/out)	m	170 / 50 (OD above) 35 (OD below)	170 / 50 (OD above) 35 (OD below)
Pipe length for nominal capacity	m	7,5	7,5
Pipe length for additional gas / Additional gas amount (R410A)	m / g/m	0 < / Refer to manual	0 < / Refer to manual
Operation range	Heat Min ~ Max	°C	-11 ~ +15 <sup>3)</sup>
Water outlet temperature range	Cool Min ~ Max	°C	+5 ~ +15
	Heat Min ~ Max	°C	+35 ~ +45

1) Unit efficiency energy level: Scale from A+++ to D. 2) Seasonal space cooling/heating energy efficiency following COMMISSION REGULATION (EU) 813/2013. 3) With accessory low temperature kit -25 ~ +15 °C. Available only as a spare part.

Performance calculation in agreement with Eurovent. Sound pressure measured at 1 m from the outdoor unit and at 1,5 m height.

#### Accessories







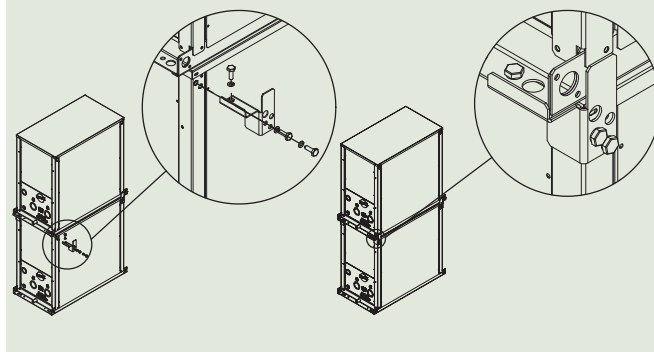





































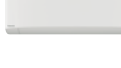

**PAW-3WSK** Stacking kit for vertically stacking up to 3 WHE (4 pieces per Kit)







#### Stacking kit PAW-3WSK.

It is possible to stack up to 3 units. When stacking units, always anchor the bottom unit to the ground using the anchor holes.



# ECOi systems indoor units range

Page		1,5 kW	2,2 kW	2,8 kW	3,0 kW	3,6 kW	4,0 kW	4,5 kW
P. 196	U2 Type 4 Way 90x90 Cassette							
			S-22MU2E5A	S-28MU2E5A		S-36MU2E5A		S-45MU2E5A
P. 196	Y2 Type 4 Way 60x60 Cassette							
		S-15MY2E5A	S-22MY2E5A	S-28MY2E5A		S-36MY2E5A		S-45MY2E5A
P. 197	L1 Type 2 Way Cassette							
			S-22ML1E5	S-28ML1E5		S-36ML1E5		S-45ML1E5
P. 197	D1 Type 1 Way Cassette							
				S-28MD1E5		S-36MD1E5		S-45MD1E5
P. 198	F2 Type Variable Static Pressure Hide Away							
		S-15MF2E5A	S-22MF2E5A	S-28MF2E5A		S-36MF2E5A		S-45MF2E5A
P. 198	M1 Type Slim Variable Static Pressure Hide Away							
		S-15MM1E5A	S-22MM1E5A	S-28MM1E5A		S-36MM1E5A		S-45MM1E5A
P. 199	E2 Type High Static Pressure Hide Away							
P. 199	Heat Recovery with DX Coil							
					PAW-500ZDX3N		PAW-800ZDX3N	PAW-01KZDX3N
P. 200	T2 Type Ceiling							
						S-36MT2E5A		S-45MT2E5A
P. 200	K2 Type Wall-mounted							
		S-15MK2E5A	S-22MK2E5A	S-28MK2E5A		S-36MK2E5A		S-45MK2E5A
P. 201	G1 Type Floor Console							
			S-22MG1E5N	S-28MG1E5N		S-36MG1E5N		S-45MG1E5N
P. 201	P1 Type Floor-standing							
			S-22MP1E5	S-28MP1E5		S-36MP1E5		S-45MP1E5
P. 201	R1 Type Concealed Floor-standing							
			S-22MR1E5	S-28MR1E5		S-36MR1E5		S-45MR1E5
P. 202	Hydrokit for ECOi, water at 45 °C							

Page		16,0 kW	28,0 kW	56,0 kW	84,0 kW	112,0 kW	140,0 kW	168,0 kW
P. 202	AHU Connection Kit 16, 28 and 56 kW							
		PAW-160MAH2/M/L	PAW-280MAH2/M/L	PAW-560MAH2/M/L	PAW-280MAH2/M/L + PAW-560MAH2/M/L	PAW-560MAH2/M/L x2	PAW-280MAH2/M/L + PAW-560MAH2/M/L x2	PAW-560MAH2/M/L x3

Page		250 m³/h	350 m³/h	500 m³/h	800 m³/h	1000 m³/h
P. 203	Energy Recovery Ventilation					
		FY-250ZDY8R	FY-350ZDY8R	FY-500ZDY8R	FY-800ZDY8R	FY-01KZDY8R

**5,6 kW      6,0 kW      7,3 kW      9,0 kW      10,6 kW      14,0 kW      16,0 kW      22,4 kW      28,0 kW**



S-56MU2E5A    S-60MU2E5A    S-73MU2E5A    S-90MU2E5A    S-106MU2E5A    S-140MU2E5A    S-160MU2E5A



S-56MY2E5A



S-56ML1E5



S-73ML1E5



S-56MD1E5



S-73MD1E5



S-56MF2E5A    S-60MF2E5A    S-73MF2E5A    S-90MF2E5A    S-106MF2E5A    S-140MF2E5A    S-160MF2E5A



S-56MM1E5A



S-224ME2E5



S-280ME2E5



S-56MT2E5A



S-73MT2E5A



S-106MT2E5A



S-140MT2E5A

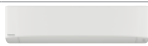

S-56MK2E5A

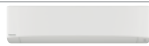

S-73MK2E5A

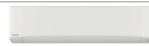

S-106MK2E5A



S-56MG1E5N



S-56MP1E5



S-71MP1E5



S-56MR1E5



S-71MR1E5



S-80MW1E5



S-125MW1E5

**Page**

**7,9 kW**

**12,0 kW**

**15,0 kW**

**19,0 kW**

**23,6 kW**

**27,6 kW**

**P. 203**

Air Curtain LS type with DX Coil



PAW-10EAIRC-LS



PAW-15EAIRC-LS



PAW-20EAIRC-LS



PAW-25EAIRC-LS

**P. 203**

Air Curtain HS type with DX Coil



PAW-10EAIRC-HS



PAW-15EAIRC-HS



PAW-20EAIRC-HS



PAW-25EAIRC-HS



ECONAVI, NANOEX™ X and INTERNET CONTROL: Optional.

**U2 Type 4 Way 90x90 Cassette**

**Tentative data**

Model			S-22MU2E5A	S-28MU2E5A	S-36MU2E5A	S-45MU2E5A	S-56MU2E5A	S-60MU2E5A	S-73MU2E5A	S-90MU2E5A	S-106MU2E5A	S-140MU2E5A	S-160MU2E5A
Cooling capacity	kW		2,2	2,8	3,6	4,5	5,6	6,0	7,3	9,0	10,6	14,0	16,0
Input power cooling	W		20,00	20,00	20,00	20,00	25,00	35,00	40,00	40,00	95,00	100,00	115,00
Current (cool)	A		0,19	0,19	0,19	0,19	0,22	0,31	0,33	0,36	0,71	0,76	0,89
Heating capacity	kW		2,5	3,2	4,2	5,0	6,3	7,1	8,0	10,0	11,4	16,0	18,0
Input power heating	W		20,00	20,00	20,00	20,00	25,00	35,00	40,00	40,00	85,00	100,00	105,00
Current (heat)	A		0,17	0,17	0,17	0,17	0,20	0,30	0,32	0,34	0,65	0,73	0,80
Fan type			Turbo fan	Turbo fan	Turbo fan	Turbo fan	Turbo fan	Turbo fan	Turbo fan	Turbo fan	Turbo fan	Turbo fan	Turbo fan
Air volume	Hi/ Med/ Lo	m³/min	14,50/	14,50/	14,50/	15,50/	17,00/	21,00/	22,50/	23,00/	35,00/	36,00/	37,00/
			13,00/	13,00/	13,00/	13,00/	13,50/	16,00/	16,00/	18,50/	26,00/	27,00/	29,00/
			11,50	11,50	11,50	11,50	11,50	13,00	13,00	14,00	20,00	21,50	25,00
Sound pressure	Hi/ Med/ Lo	dB(A)	30/	30/	30/	31/	33/	36/	37/	38/	44/	45/	46/
			29/	29/	29/	29/	30/	32/	32/	35/	38/	39/	40/
			28	28	28	28	28	29	29	32	34	35	38
Sound power	Hi/ Med/ Lo	dB(A)	45/	45/	45/	46/	48/	51/	52/	53/	59/	60/	61/
			44/	44/	44/	44/	45/	47/	47/	50/	53/	54/	55/
			43	43	43	43	43	44	44	47	49	50	53
Dimension (HxWxD)	Indoor	mm	256 x 840 x 840	256 x 840 x 840	256 x 840 x 840	256 x 840 x 840	256 x 840 x 840	256 x 840 x 840	256 x 840 x 840	256 x 840 x 840	319 x 840 x 840	319 x 840 x 840	319 x 840 x 840
	Panel	mm	33,5 x 950 x 950	33,5 x 950 x 950	33,5 x 950 x 950	33,5 x 950 x 950	33,5 x 950 x 950	33,5 x 950 x 950	33,5 x 950 x 950	33,5 x 950 x 950	33,5 x 950 x 950	33,5 x 950 x 950	33,5 x 950 x 950
Net weight (Panel)	kg		19(5)	19(5)	19(5)	19(5)	19(5)	20(5)	20(5)	20(5)	25(5)	25(5)	25(5)
Piping connections	Liquid	Inch (mm)	1/4(6,35)	1/4(6,35)	1/4(6,35)	1/4(6,35)	1/4(6,35)	3/8(9,52)	3/8(9,52)	3/8(9,52)	3/8(9,52)	3/8(9,52)	3/8(9,52)
	Gas	Inch (mm)	1/2(12,70)	1/2(12,70)	1/2(12,70)	1/2(12,70)	1/2(12,70)	5/8(15,88)	5/8(15,88)	5/8(15,88)	5/8(15,88)	5/8(15,88)	5/8(15,88)



ECONAVI and INTERNET CONTROL: Optional.

**Y2 Type 4 Way 60x60 Cassette**

Model			S-15MY2E5A	S-22MY2E5A	S-28MY2E5A	S-36MY2E5A	S-45MY2E5A	S-56MY2E5A
Cooling capacity	kW		1,5	2,2	2,8	3,6	4,5	5,6
Input power cooling	W		35,00	35,00	35,00	40,00	40,00	45,00
Operating current cooling	A		0,30	0,30	0,30	0,30	0,32	0,35
Heating capacity	kW		1,7	2,5	3,2	4,2	5,0	6,3
Input power heating	W		30,00	30,00	30,00	35,00	35,00	40,00
Operating current heating	A		0,25	0,25	0,30	0,30	0,30	0,30
Fan type			Centrifugal fan	Centrifugal fan	Centrifugal fan	Centrifugal fan	Centrifugal fan	Centrifugal fan
Air volume (Hi / Med / Lo)	Cool	m³/min	8,90/8,20/5,60	9,10/8,20/5,60	9,30/8,40/5,60	9,70/8,70/6,00	10,00/9,30/8,20	10,40/9,80/8,50
	Heat	m³/min	9,10/8,40/5,60	9,30/8,40/5,60	9,60/8,70/5,60	9,90/9,10/6,00	10,30/9,60/8,20	11,10/9,80/8,70
Sound pressure	Hi / Med / Lo	dB(A)	34/31/25	35/31/25	35/31/25	36/32/26	38/34/28	40/37/34
Sound power	Hi / Med / Lo	dB(A)	49/46/40	50/46/40	50/46/40	51/47/41	53/49/43	55/52/49
Dimension (HxWxD)	Indoor	mm	288 x 583 x 583	288 x 583 x 583	288 x 583 x 583	288 x 583 x 583	288 x 583 x 583	288 x 583 x 583
	Panel 3A	mm	31 x 700 x 700	31 x 700 x 700	31 x 700 x 700	31 x 700 x 700	31 x 700 x 700	31 x 700 x 700
	Panel 3B	mm	31 x 625 x 625	31 x 625 x 625	31 x 625 x 625	31 x 625 x 625	31 x 625 x 625	31 x 625 x 625
Net weight	kg		20,4(18+2,4)	20,4(18+2,4)	20,4(18+2,4)	20,4(18+2,4)	20,4(18+2,4)	20,4(18+2,4)
Piping connections	Liquid pipe	Inch (mm)	1/4(6,35)	1/4(6,35)	1/4(6,35)	1/4(6,35)	1/4(6,35)	1/4(6,35)
	Gas pipe	Inch (mm)	1/2(12,70)	1/2(12,70)	1/2(12,70)	1/2(12,70)	1/2(12,70)	1/2(12,70)



**L1 Type 2 Way Cassette**

Model		S-22ML1E5	S-28ML1E5	S-36ML1E5	S-45ML1E5	S-56ML1E5	S-73ML1E5	
Cooling capacity	kW	2,2	2,8	3,6	4,5	5,6	7,3	
Input power cooling	W	90,00	92,00	93,00	97,00	97,00	145,00	
Operating current cooling	A	0,45	0,45	0,45	0,45	0,45	0,65	
Heating capacity	kW	2,5	3,2	4,2	5,0	6,3	8,0	
Input power heating	W	58,00	60,00	61,00	65,00	65,00	109,00	
Operating current heating	A	0,29	0,29	0,29	0,29	0,29	0,48	
Fan type		Sirocco fan	Sirocco fan	Sirocco fan	Sirocco fan	Sirocco fan	Sirocco fan	
Air volume	Hi / Med / Lo	m <sup>3</sup> /min	8,00/7,00/6,00	9,00/8,00/7,00	9,70/8,70/7,70	11,00/9,00/8,00	11,00/9,00/8,00	19,00/16,00/14,00
Sound pressure	Hi / Med / Lo	dB(A)	30/27/24	33/29/26	34/31/28	35/33/29	35/33/29	38/35/33
Dimension (HxWxD)	Indoor	mm	350 x 840 x 600	350 x 840 x 600	350 x 840 x 600	350 x 840 x 600	350 x 840 x 600	350 x 1140 x 600
	Panel	mm	8 x 1060 x 680	8 x 1060 x 680	8 x 1060 x 680	8 x 1060 x 680	8 x 1060 x 680	8 x 1360 x 680
Net weight (Panel)	kg	26,0(8,0)	26,0(8,0)	26,0(8,0)	26,0(8,0)	26,0(8,0)	26,0(8,0)	
Piping connections	Liquid pipe	Inch (mm)	1/4(6,35)	1/4(6,35)	1/4(6,35)	1/4(6,35)	1/4(6,35)	3/8(9,52)
	Gas pipe	Inch (mm)	1/2(12,70)	1/2(12,70)	1/2(12,70)	1/2(12,70)	1/2(12,70)	5/8(15,88)



**D1 Type 1 Way Cassette**

Model		S-28MD1E5	S-36MD1E5	S-45MD1E5	S-56MD1E5	S-73MD1E5	
Cooling capacity	kW	2,8	3,6	4,5	5,6	7,3	
Input power cooling	W	51,00	51,00	51,00	60,00	87,00	
Operating current cooling	A	0,39	0,39	0,39	0,46	0,70	
Heating capacity	kW	3,2	4,2	5,0	6,3	8,0	
Input power heating	W	40,00	40,00	40,00	48,00	76,00	
Operating current heating	A	0,35	0,35	0,35	0,41	0,65	
Fan type		Sirocco fan	Sirocco fan	Sirocco fan	Sirocco fan	Sirocco fan	
Air volume	Hi / Med / Lo	m <sup>3</sup> /min	12,00/10,00/9,00	12,00/10,00/9,00	12,00/11,00/10,00	13,00/11,50/10,00	18,00/15,00/13,00
Sound pressure	Hi / Med / Lo	dB(A)	36/34/33	36/34/33	36/35/34	38/36/34	45/40/36
Dimension (HxWxD)	Indoor	mm	200 x 1000 x 710	200 x 1000 x 710	200 x 1000 x 710	200 x 1000 x 710	200 x 1000 x 710
	Panel	mm	20 x 1230 x 800	20 x 1230 x 800	20 x 1230 x 800	20 x 1230 x 800	20 x 1230 x 800
Net weight (Panel)	kg	23,5(7,5)	23,5(7,5)	23,5(7,5)	23,5(7,5)	24,5(7,5)	
Piping connections	Liquid pipe	Inch (mm)	1/4(6,35)	1/4(6,35)	1/4(6,35)	1/4(6,35)	3/8(9,52)
	Gas pipe	Inch (mm)	1/2(12,70)	1/2(12,70)	1/2(12,70)	1/2(12,70)	5/8(15,88)



## F2 Type Variable Static Pressure Hide Away

Model		S-15MF2E5A	S-22MF2E5A	S-28MF2E5A	S-36MF2E5A	S-45MF2E5A	S-56MF2E5A	S-60MF2E5A	S-73MF2E5A	S-90MF2E5A	S-106MF2E5A	S-140MF2E5A	S-160MF2E5A
Cooling capacity	kW	1,5	2,2	2,8	3,6	4,5	5,6	6,0	7,3	9,0	10,6	14,0	16,0
Input power cooling	W	70,00	70,00	70,00	70,00	70,00	100,00	120,00	120,00	135,00	195,00	215,00	225,00
Current (cool)	A	0,57	0,57	0,57	0,57	0,57	0,74	0,89	0,89	0,97	1,30	1,44	1,50
Heating capacity	kW	1,7	2,5	3,2	4,2	5,0	6,3	7,1	8,0	10,0	11,4	16,0	18,0
Input power heating	W	70,00	70,00	70,00	70,00	70,00	100,00	120,00	120,00	135,00	200,00	210,00	225,00
Current (heat)	A	0,57	0,57	0,57	0,57	0,57	0,74	0,89	0,89	0,97	1,34	1,42	1,50
Fan type		Sirocco fan	Sirocco fan	Sirocco fan	Sirocco fan	Sirocco fan	Sirocco fan	Sirocco fan	Sirocco fan	Sirocco fan	Sirocco fan	Sirocco fan	Sirocco fan
Air volume <sup>1)</sup>	Hi / Med / Lo	14,00 / 13,00 / 9,00	14,00 / 13,00 / 9,00	14,00 / 13,00 / 9,00	14,00 / 13,00 / 9,00	14,00 / 13,00 / 10,00	16,00 / 15,00 / 12,00	21,00 / 19,00 / 15,00	21,00 / 19,00 / 15,00	25,00 / 23,00 / 19,00	32,00 / 26,00 / 21,00	34,00 / 29,00 / 23,00	36,00 / 32,00 / 25,00
	Unit	m <sup>3</sup> /min											
	External static pressure	Pa	70 (10-150)	70 (10-150)	70 (10-150)	70 (10-150)	70 (10-150)	70 (10-150)	70 (10-150)	70 (10-150)	70 (10-150)	100 (10-150)	100 (10-150)
Sound pressure	Hi / Med / Lo	33 / 29 / 22	33 / 29 / 22	33 / 29 / 22	33 / 29 / 22	34 / 32 / 25	34 / 32 / 25	35 / 32 / 26	35 / 32 / 26	37 / 34 / 28	38 / 34 / 31	39 / 35 / 32	40 / 36 / 33
	Unit	dB(A)											
	Sound power	dB(A)	55 / 51 / 44	55 / 51 / 44	55 / 51 / 44	55 / 51 / 44	56 / 54 / 47	56 / 54 / 47	57 / 54 / 48	57 / 54 / 48	59 / 56 / 50	60 / 56 / 53	61 / 57 / 54
Dimension	HxWxD mm	290x800 x700	290x800 x700	290x800 x700	290x800 x700	290x800 x700	290x800 x700	290x1000 x700	290x1000 x700	290x1000 x700	290x1400 x700	290x1400 x700	290x1400 x700
Net weight	kg	29	29	29	29	29	29	34	34	34	46	46	46
Piping connections	Liquid	Inch (mm)	1/4(6,35)	1/4(6,35)	1/4(6,35)	1/4(6,35)	1/4(6,35)	3/8(9,52)	3/8(9,52)	3/8(9,52)	3/8(9,52)	3/8(9,52)	3/8(9,52)
	Gas	Inch (mm)	1/2(12,70)	1/2(12,70)	1/2(12,70)	1/2(12,70)	1/2(12,70)	5/8(15,88)	5/8(15,88)	5/8(15,88)	5/8(15,88)	5/8(15,88)	5/8(15,88)

1) Value referred to standard settings at shipment (H curve 8, M curve 5, L curve 1).



## M1 Type Slim Variable Static Pressure Hide Away Concealed Duct

Model		S-15MM1E5A	S-22MM1E5A	S-28MM1E5A	S-36MM1E5A	S-45MM1E5A	S-56MM1E5A
Cooling capacity	kW	1,5	2,2	2,8	3,6	4,5	5,6
Input power cooling	W	36,00	36,00	40,00	42,00	49,00	64,00
Operating current cooling	A	0,26	0,26	0,30	0,31	0,37	0,48
Heating capacity	kW	1,7	2,5	3,2	4,2	5,0	6,3
Input power heating	W	26,00	26,00	30,00	32,00	39,00	54,00
Operating current heating	A	0,23	0,23	0,27	0,28	0,34	0,45
Fan type		Sirocco fan	Sirocco fan	Sirocco fan	Sirocco fan	Sirocco fan	Sirocco fan
Air volume	Hi / Med / Lo	8,00 / 7,00 / 6,00	8,00 / 7,00 / 6,00	8,50 / 7,50 / 6,50	9,00 / 8,00 / 7,00	10,50 / 9,50 / 8,00	12,50 / 11,50 / 10,00
External static pressure	Pa	10 (30)	10 (30)	15 (30)	15 (40)	15 (40)	15 (40)
Sound pressure	Hi / Med / Lo <sup>1)</sup>	28 / 27 / 25 (30 / 29 / 27)	28 / 27 / 25 (30 / 29 / 27)	30 / 29 / 27 (32 / 31 / 29)	32 / 30 / 28 (34 / 32 / 30)	34 / 32 / 30 (36 / 34 / 32)	35 / 33 / 31 (37 / 35 / 32)
	Unit	dB(A)					
Sound power	dB(A)	43 / 42 / 40	43 / 42 / 40	45 / 44 / 42	47 / 45 / 43	49 / 47 / 45	50 / 48 / 46
Dimension	HxWxD mm	200x750x640	200x750x640	200x750x640	200x750x640	200x750x640	200x750x640
Net weight	kg	19	19	19	19	19	19
Piping connections	Liquid pipe	Inch (mm)	1/4(6,35)	1/4(6,35)	1/4(6,35)	1/4(6,35)	1/4(6,35)
	Gas pipe	Inch (mm)	1/2(12,70)	1/2(12,70)	1/2(12,70)	1/2(12,70)	1/2(12,70)

1) By DIP switches or by RC setting.



### E2 Type High Static Pressure Hide Away

Model	100 % Fresh air duct function (by using Kit for 100 % Fresh air)						High pressure duct				
	S-224ME2E5		S-280ME2E5		S-224ME2E5		S-280ME2E5				
	Cooling	Heating	Cooling	Heating	Cooling	Heating	Cooling	Heating	Cooling	Heating	
Capacity	kW	22,4	21,2	28,0	26,5	22,4	25,0	28,0	31,5		
Input power	W	290,00	290,00	350,00	350,00	440,00	440,00	715,00	715,00		
Operating current	A	1,85	1,85	2,20	2,20	2,45	2,45	3,95	3,95		
Air volume	Hi / Med / Lo	m <sup>3</sup> /min 28,30 / — / —		35,00 / — / —		56,00 / 51,00 / 44,00		72,00 / 63,00 / 53,00			
External static pressure	Pa	200		200		140 (60 - 270) <sup>1)</sup>		140 (72 - 270) <sup>1)</sup>			
Sound pressure <sup>2)</sup>	Hi / Med / Lo	dB(A) 43 / — / —		44 / — / —		45 / 43 / 41		49 / 47 / 43			
Sound power	Hi / Med / Lo	dB(A) 75 / — / —		76 / — / —		77 / 75 / 73		81 / 79 / 75			
Dimension	H x W x D	mm 479 x 1453 x 1205		479 x 1453 x 1205		479 x 1453 x 1205		479 x 1453 x 1205			
Net weight	kg	102		106		102		106			
Piping connections	Liquid pipe	Inch (mm)	3/8 (9,52)		3/8 (9,52)		3/8 (9,52)		3/8 (9,52)		
	Gas pipe	Inch (mm)	3/4 (19,05)		7/8 (22,22)		3/4 (19,05)		7/8 (22,22)		

#### KIT for 100 % Fresh air function for 2 Way systems

<b>2x CZ-P160RVK2</b>	Rap valve kit
<b>2x CZ-CAPE2</b>	3 Way control PCB
<b>CZ-P680BK2BM</b>	Distribution Joint kit
	1x Remote controller

#### KIT for 100 % Fresh air function for 3 Way systems

<b>2x CZ-P160HR3</b>	3 way valve Kit
<b>2x CZ-CAPE2</b>	3 Way control PCB
<b>CZ-P680BH2BM</b>	Distribution Joint kit
	1x Remote controller

Rating Conditions for 100 % Fresh air duct function: Cooling Outdoor 33 °C DB / 28 °C WB. Heating Outdoor 0 °C DB / -2,9 °C WB. 1) Available to select the setting by initial setup. 2) Values with 140 Pa setting. \* No filter included.

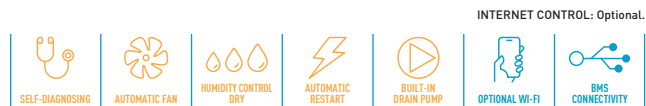

### Heat Recovery with DX Coil

Model	PAW-500ZDX3N				PAW-800ZDX3N		PAW-01KZDX3N		
	Voltage	V	230		230		230		
	Phase	Hz	Single Phase		Single Phase		Single Phase		
Power source	Frequency	Hz	50		50		50		
Air volume	m <sup>3</sup> /min	8,33		13,33		16,67			
External static pressure <sup>1)</sup>	Pa	90		120		115			
Maximum current	Total full load	A	0,6		1,4		2,1		
Input power	W	150		320		390			
Sound pressure <sup>2)</sup>	dB(A)	39		42		43			
Piping connections	Liquid pipe	Inch (mm)	1/4 (6,35)		1/4 (6,35)		1/4 (6,35)		
	Gas pipe	Inch (mm)	1/2 (12,70)		1/2 (12,70)		1/2 (12,70)		
<b>Heat recovery</b>		<b>Cooling</b>	<b>Heating</b>	<b>Cooling</b>	<b>Heating</b>	<b>Cooling</b>	<b>Heating</b>		
Temperature efficiency	%	76	76	76	76	76	76		
Enthalpy efficiency	%	63	67	63	65	60	62		
Saved power summer mode or winter mode*	kW	1,70	4,30 (4,80)		2,50		6,50 (7,30)		
<b>DX Coil</b>									
Total / Sensible capacity	kW	3,00 / 2,10		2,50 / 2,70		5,10 / 3,50		4,40 / 4,80	
OFF temperature	°C	15,9		28,0 (27,3)		15,5		29,6 (29,0)	
OFF relative humidity	%	90		16 (15)		90		14 (13)	

Nominal summer conditions: Outside air: 32 °C DB, RH 50 %. Ambient air: 26 °C DB, RH 50 %. Nominal winter conditions: Outside air: -5 °C DB, RH 80 %. Ambient air: 20 °C DB, RH 50 %. Cooling mode air inlet condition: 28,5 °C DB, RH 50 %; evaporating temperature 7 °C. Heating mode air inlet condition: 13 °C DB, RH 40 % (11 °C DB, RH 45 %); condensating temperature 40 °C. DB: Dry Bulb; RH: Relative Humidity. 1) Referred to the nominal air flow after filter and plate heat exchanger. 2) Sound pressure level calculated at 1 m far from: ducted supply exhaust air ducted return - first air intake / service side, at normal condition. \* Tentative data.



ECONAVI and INTERNET CONTROL: Optional.

## T2 Type Ceiling

Model		S-36MT2E5A	S-45MT2E5A	S-56MT2E5A	S-73MT2E5A	S-106MT2E5A	S-140MT2E5A	
Cooling capacity	kW	3,6	4,5	5,6	7,3	10,6	14,0	
Input power cooling	W	35,00	40,00	40,00	55,00	80,00	100,00	
Operating current cooling	A	0,36	0,38	0,38	0,44	0,67	0,79	
Heating capacity	kW	4,2	5,0	6,3	8,0	11,4	16,0	
Input power heating	W	35,00	40,00	40,00	55,00	80,00	100,00	
Operating current heating	A	0,36	0,38	0,38	0,44	0,67	0,79	
Fan type		Sirocco fan	Sirocco fan	Sirocco fan	Sirocco fan	Sirocco fan	Sirocco fan	
Air volume	Hi / Med / Lo	m <sup>3</sup> /min	14,00/12,00/10,50	15,00/12,50/10,50	15,00/12,50/10,50	21,00/18,00/15,50	30,00/25,00/23,00	32,00/28,00/24,00
Sound pressure	Hi / Med / Lo	dB(A)	36/32/30	37/33/30	37/33/30	39/35/33	42/37/36	46/40/37
Sound power	Hi / Med / Lo	dB(A)	54/50/48	55/51/48	55/51/48	57/53/51	60/55/54	62/58/55
Dimension	H x W x D	mm	235 x 960 x 690	235 x 960 x 690	235 x 960 x 690	235 x 1275 x 690	235 x 1590 x 690	235 x 1590 x 690
Net weight		kg	27	27	27	33	40	40
Piping connections	Liquid pipe	Inch (mm)	1/4 (6,35)	1/4 (6,35)	1/4 (6,35)	3/8 (9,52)	3/8 (9,52)	3/8 (9,52)
	Gas pipe	Inch (mm)	1/2 (12,70)	1/2 (12,70)	1/2 (12,70)	5/8 (15,88)	5/8 (15,88)	5/8 (15,88)



ECONAVI and INTERNET CONTROL: Optional.

## K2 Type Wall-mounted

Model		S-15MK2E5A	S-22MK2E5A	S-28MK2E5A	S-36MK2E5A	S-45MK2E5A	S-56MK2E5A	S-73MK2E5A	S-106MK2E5A	
Cooling capacity	kW	1,5	2,2	2,8	3,6	4,5	5,6	7,3	10,6	
Input power cooling	W	25,00	25,00	25,00	30,00	30,00	35,00	55,00	80,00	
Operating current cooling	A	0,20	0,21	0,23	0,25	0,32	0,35	0,51	0,70	
Heating capacity	kW	1,7	2,5	3,2	4,2	5,0	6,3	8,0	11,4	
Input power heating	W	25,00	25,00	25,00	30,00	30,00	35,00	55,00	80,00	
Operating current heating	A	0,20	0,21	0,23	0,25	0,32	0,35	0,51	0,70	
Fan type		Cross flow	Cross flow	Cross flow	Cross flow	Cross flow	Cross flow	Cross flow	Cross flow	
Air volume	Cool	m <sup>3</sup> /min	7,90/7,40/6,50	9,00/7,50/6,50	9,50/8,30/6,50	10,90/9,00/6,50	14,50/12,50/10,00	16,00/14,00/12,00	19,50/17,00/14,00	21,50/18,50/15,00
	Hi / Med / Lo	Heat	m <sup>3</sup> /min	9,00/7,70/6,80	9,20/8,30/6,80	9,70/8,50/6,80	11,20/9,50/6,80	14,50/12,50/10,00	16,00/14,00/12,00	19,50/17,00/14,00
Sound pressure	Hi / Med / Lo	dB(A)	34/32/29	36/33/29	37/34/29	40/36/29	38/35/33	40/37/35	47/44/40	49/46/42
Sound power	Hi / Med / Lo	dB(A)	49/47/44	51/48/44	52/49/44	55/51/44	53/50/48	55/52/50	62/59/55	64/61/57
Dimension	H x W x D	mm	290 x 870 x 214	290 x 870 x 214	290 x 870 x 214	290 x 870 x 214	302 x 1120 x 236	302 x 1120 x 236	302 x 1120 x 236	302 x 1120 x 236
Net weight		kg	9	9	9	9	13	13	14	14
Piping connections	Liquid pipe	Inch (mm)	1/4 (6,35)	1/4 (6,35)	1/4 (6,35)	1/4 (6,35)	1/4 (6,35)	1/4 (6,35)	3/8 (9,52)	3/8 (9,52)
	Gas pipe	Inch (mm)	1/2 (12,70)	1/2 (12,70)	1/2 (12,70)	1/2 (12,70)	1/2 (12,70)	1/2 (12,70)	5/8 (15,88)	5/8 (15,88)





ECONAVI and INTERNET CONTROL: Optional.



**G1 Type Floor Console**

Model		S-22MG1E5N	S-28MG1E5N	S-36MG1E5N	S-45MG1E5N	S-56MG1E5N	
Cooling capacity	kW	2,2	2,8	3,6	4,5	5,6	
Input power cooling	W	20,00	20,00	22,00	28,00	31,00	
Operating current cooling	A	0,20	0,20	0,23	0,25	0,28	
Heating capacity	kW	2,5	3,2	4,2	5,0	6,3	
Input power heating	W	21,00	21,00	23,00	29,00	32,00	
Operating current heating	A	0,20	0,20	0,24	0,26	0,28	
Fan type		Cross flow	Cross flow	Cross flow	Cross flow	Cross flow	
Air volume	Cool (Hi / Med / Lo)	m³/min	9,20/7,50/6,00	9,20/7,50/6,00	9,70/8,20/6,00	10,50/9,00/6,50	12,00/9,50/6,50
	Heat (Hi / Med / Lo)	m³/min	9,70/8,00/6,50	9,70/8,00/6,50	10,20/8,70/6,50	11,00/9,50/7,00	12,50/10,00/7,00
Sound pressure	Hi / Med / Lo	dB(A)	38/34/29	38/34/29	39/35/29	42/37/30	44/38/30
Dimension	H x W x D	mm	600 x 750 x 207	600 x 750 x 207	600 x 750 x 207	600 x 750 x 207	600 x 750 x 207
Net weight		kg	14	14	14	14	14
Piping connections	Liquid pipe	Inch (mm)	1/4 (6,35)	1/4 (6,35)	1/4 (6,35)	1/4 (6,35)	1/4 (6,35)
	Gas pipe	Inch (mm)	1/2 (12,70)	1/2 (12,70)	1/2 (12,70)	1/2 (12,70)	1/2 (12,70)



INTERNET CONTROL: Optional.



**P1 Type Floor-standing / R1 Type Concealed Floor-standing**

Model P1 Type		S-22MP1E5	S-28MP1E5	S-36MP1E5	S-45MP1E5	S-56MP1E5	S-71MP1E5	
Model R1 Type		S-22MR1E5	S-28MR1E5	S-36MR1E5	S-45MR1E5	S-56MR1E5	S-71MR1E5	
Cooling capacity	kW	2,2	2,8	3,6	4,5	5,6	7,1	
Input power cooling	W	56,00	56,00	85,00	126,00	126,00	160,00	
Operating current cooling	A	0,25	0,25	0,38	0,56	0,56	0,72	
Heating capacity	kW	2,5	3,2	4,2	5,0	6,3	8,0	
Input power heating	W	40,00	40,00	70,00	91,00	91,00	120,00	
Operating current heating	A	0,18	0,18	0,31	0,41	0,41	0,54	
Fan type		Sirocco fan	Sirocco fan	Sirocco fan	Sirocco fan	Sirocco fan	Sirocco fan	
Air volume	Hi / Med / Lo	m³/min	7,00/6,00/5,00	7,00/6,00/5,00	9,00/7,00/6,00	12,00/9,00/8,00	15,00/13,00/11,00	17,00/14,00/12,00
External static pressure		Pa	15	15	15	15	15	
Sound pressure	Hi / Med / Lo	dB(A)	33/30/28	33/30/28	39/35/29	38/35/31	39/36/31	41/38/35
Dimensions P1	H x W x D	mm	615 x 1065 x 230	615 x 1065 x 230	615 x 1065 x 230	615 x 1380 x 230	615 x 1380 x 230	
Net weight P1		kg	29	29	29	39	39	
Dimensions R1	H x W x D	mm	616 x 904 x 229	616 x 904 x 229	616 x 904 x 229	616 x 1219 x 229	616 x 1219 x 229	
Net weight R1		kg	21	21	21	28	28	
Piping connections	Liquid pipe	Inch (mm)	1/4 (6,35)	1/4 (6,35)	1/4 (6,35)	1/4 (6,35)	3/8 (9,52)	
	Gas pipe	Inch (mm)	1/2 (12,70)	1/2 (12,70)	1/2 (12,70)	1/2 (12,70)	5/8 (15,88)	



### Hydrokit for ECOi, water at 45 °C

Model				S-80MW1E5	S-125MW1E5	
Power source				230 V / Single Phase / 50 Hz		
Cooling capacity	kW			8,0	12,5	
Heating capacity	kW			9,0	14,0	
Maximum temperature	°C			-45/-65 <sup>1)</sup>	-45/-65 <sup>1)</sup>	
Dimension	H x W x D	mm		892 x 502 x 353		
Water pipe connector		Inch		R 1 ¼		
Water pump (built-in)				DC motor (A class)		
Water flow rate	Cool	L/min			22,90	35,80
	Heat	L/min			25,80	40,10
Piping connections	Liquid pipe	Inch (mm)			3/8 (9,52)	3/8 (9,52)
	Gas pipe	Inch (mm)			5/8 (15,88)	5/8 (15,88)
	Drain piping			15 - 17 mm (inner size)		15 - 17 mm (inner size)
Operation range	Cool	Ambient	°C	+10 ~ +43		+10 ~ +43
		Water	°C	+5 ~ +20		+5 ~ +20
	Heat	Ambient	°C	-20 ~ +43		-20 ~ +43
		Water	°C	+25 ~ +45		+25 ~ +45
Connectable system				3-Pipe (heat recovery type) VRF System (system capable up to 48 HP)		
Maximum Indoor ratio (connectable hydrokit module capacity ratio)				Total indoor unit + Hydrokit capacity: up to 130 % (** ~ **% vs total outdoor unit capacity)		

1) Max 45 °C by refrigerant circuit (heat pump cycle), over 45 °C is provided by electric heater operation.

## Panasonic Ventilation Solutions



### AHU Connection Kit 16, 28 and 56 kW for ECOi

<b>PAW-160MAH2</b>	AHU Kit for 16 kW (IP 65, 0-10V demand control*, Outdoor temperature shift compensation. Cold draft prevention)
<b>PAW-280MAH2</b>	AHU Kit for 28 kW (IP 65, 0-10V demand control*, Outdoor temperature shift compensation. Cold draft prevention)
<b>PAW-560MAH2</b>	AHU Kit for 56 kW (IP 65, 0-10V demand control*, Outdoor temperature shift compensation. Cold draft prevention)
<b>PAW-160MAH2M</b>	AHU Kit for 16 kW (IP 65, 0-10V demand control*)
<b>PAW-280MAH2M</b>	AHU Kit for 28 kW (IP 65, 0-10V demand control*)
<b>PAW-560MAH2M</b>	AHU Kit for 56 kW (IP 65, 0-10V demand control*)
<b>PAW-160MAH2L</b>	AHU Kit for 16 kW (IP 65)
<b>PAW-280MAH2L</b>	AHU Kit for 28 kW (IP 65)
<b>PAW-560MAH2L</b>	AHU Kit for 56 kW (IP 65)

\* With CZ-CAPBC2.



### Air Curtain with DX Coil

Outdoor unit			4 HP	4 HP	5 HP	8 HP
Air outlet height 2,7 m			PAW-10EAIRC-LS	PAW-15EAIRC-LS	PAW-20EAIRC-LS	PAW-25EAIRC-LS
Air volume	High	m <sup>3</sup> /h	1800	2700	3600	4500
Cooling capacity <sup>1)</sup>	Max	kW	6,1	9,7	13,0	17,0
Heating capacity <sup>2)</sup>	Max	kW	7,9	12,0	15,0	19,0
Heat Exchanger	Volume	L	1,67	2,85	3,94	5,03
Piping connections	Liquid pipe / Gas pipe	Inch (mm)	3/8 (9,52) / 5/8 (15,88)	3/8 (9,52) / 3/4 (19,05)	3/8 (9,52) / 7/8 (22,22)	3/8 (9,52) / 7/8 (22,22)
Electric consumption fan	230 V / 50Hz	kW	0,30	0,50	0,60	0,80
Fan type			EC	EC	EC	EC
Current	230 V / 50Hz	A	2,10	3,10	4,10	5,10
Sound pressure <sup>3)</sup>	Max	dB(A)	65	66	67	69
Dimension <sup>4)</sup> / Weight	H x W x D	mm / kg	260 (+140) x 1000 x 460 / 50	260 (+140) x 1500 x 460 / 65	260 (+140) x 2000 x 460 / 80	260 (+140) x 2500 x 460 / 95
Door width		m	1,0	1,5	2,0	2,5
Refrigerant			R410A	R410A	R410A	R410A

Outdoor unit			4 HP	6 HP	8 HP	10 HP
Air outlet height 3,0 m			PAW-10EAIRC-HS	PAW-15EAIRC-HS	PAW-20EAIRC-HS	PAW-25EAIRC-HS
Air volume	High	m <sup>3</sup> /h	2700	3600	5400	6300
Cooling capacity <sup>1)</sup>	Max	kW	9,1	13,0	19,5	23,7
Heating capacity <sup>2)</sup>	Max	kW	11,8	15,8	23,6	27,6
Heat Exchanger	Volume	L	1,67	2,85	3,94	5,12
Piping connections	Liquid pipe / Gas pipe	Inch (mm)	3/8 (9,52) / 5/8 (15,88)	3/8 (9,52) / 3/4 (19,05)	3/8 (9,52) / 7/8 (22,22)	3/8 (9,52) / 7/8 (22,22)
Electric consumption fan	230 V / 50Hz	kW	0,75	1,00	1,50	1,75
Fan type			EC	EC	EC	EC
Current	230 V / 50Hz	A	4,10	5,50	8,20	9,60
Sound pressure <sup>3)</sup>	Max	dB(A)	66	67	68	68
Dimension <sup>4)</sup> / Weight	H x W x D	mm / kg	260 (+140) x 1000 x 460 / 55	260 (+140) x 1500 x 460 / 65	260 (+140) x 2000 x 460 / 85	260 (+140) x 2500 x 460 / 110
Door width		m	1,0	1,5	2,0	2,5
Refrigerant			R410A	R410A	R410A	R410A

#### Accessories

<b>PAW-AIR1-DP</b>	Optional drain pump
--------------------	---------------------

1) Cooling capacity DX Coil, air temperature in/out +27/+18 °C, R32 and R410. 2) Heating capacity condenser, air temperature in/out +20/+33 °C, R32 and R410. In the case of lower outdoor temperatures, an outdoor model with higher capacity may be necessary. 3) Measured in distance up to 5,0 m, direction factor 2, absorbing surfaces 200 m<sup>2</sup>, Min / Max air volume. 4) 140 mm is the height of an electrical box if it is installed on the top.

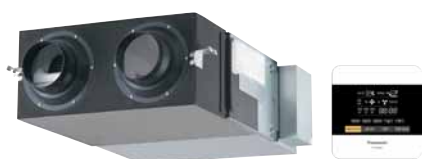

### Energy Recovery Ventilation System

Rated flow rate	250 m <sup>3</sup> /h			350 m <sup>3</sup> /h			500 m <sup>3</sup> /h			800 m <sup>3</sup> /h			1000 m <sup>3</sup> /h			
Models	FY-250ZDY8R			FY-350ZDY8R			FY-500ZDY8R			FY-800ZDY8R			FY-01KZDY8R			
Power source	220V / 240 V / 50Hz			220V / 240 V / 50Hz			220V / 240 V / 50Hz			220V / 240 V / 50Hz			220V / 240 V / 50Hz			
Heat exchange ventilation	E-High	High	Low	E-High	High	Low	E-High	High	Low	E-High	High	Low	E-High	High	Low	
Input power	W	112,00 / 128,00	108,00 / 123,00	87,00 / 96,00	182,00 / 190,00	178,00 / 185,00	175,00 / 168,00	263,00 / 289,00	204,00 / 225,00	165,00 / 185,00	387,00 / 418,00	360,00 / 378,00	293,00 / 295,00	437,00 / 464,00	416,00 / 432,00	301,00 / 311,00
Air volume	m <sup>3</sup> /h	250	250	190	350	350	240	500	500	440	800	800	630	1000	1000	700
External static pressure	Pa	105	95	45	140	60	45	120	60	35	140	110	55	105	80	75
Sound power	dB(A)	30,00 / 31,50	29,50 / 30,50	23,50 / 26,50	32,50 / 33,00	30,50 / 31,00	22,50 / 25,50	36,50 / 37,50	34,50 / 35,50	31,00 / 32,50	37,00 / 37,50	36,50 / 37,00	33,50 / 34,50	37,50 / 38,50	37,00 / 37,50	33,50 / 34,50
Temperature exchange efficiency	%	75	75	77	75	75	78	75	75	76	75	75	76	75	75	79
Normal ventilation	E-High	High	Low	E-High	High	Low	E-High	High	Low	E-High	High	Low	E-High	High	Low	
Input power	W	112,00 / 128,00	108,00 / 123,00	87,00 / 96,00	182,00 / 190,00	178,00 / 185,00	175,00 / 168,00	263,00 / 289,00	204,00 / 225,00	165,00 / 185,00	387,00 / 418,00	360,00 / 378,00	293,00 / 295,00	437,00 / 464,00	416,00 / 432,00	301,00 / 311,00
Air volume	m <sup>3</sup> /h	250	250	190	350	350	240	500	500	440	800	800	630	1000	1000	700
External static pressure	Pa	105	95	45	140	60	45	120	60	35	140	110	55	105	80	75
Sound power	dB(A)	30,00 / 31,50	29,50 / 30,50	23,50 / 26,50	32,50 / 33,00	30,50 / 31,00	22,50 / 25,50	37,50 / 38,50	37,00 / 38,00	31,00 / 32,50	37,00 / 37,50	36,50 / 37,00	33,50 / 34,50	39,50 / 40,50	39,00 / 39,50	35,50 / 36,50
Temperature exchange efficiency	%	—	—	—	—	—	—	—	—	—	—	—	—	—	—	—
Dimension	H x W x D	270 x 882 x 599			317 x 1050 x 804			317 x 1090 x 904			388 x 1322 x 884			388 x 1322 x 1134		
Net weight	kg	29			49			57			71			83		

This noise of the product is the value which was measured at the acoustic room. Actually, in the established condition, that undergo influence by the echoing of the room and so that become bigger than the display numerical value. The input, the current and the exchange efficiency are values at the time of the mentioned air volume. The noise level shall be measured 1,5 m below the centre of the unit. The temperature exchange efficiency averages that of when cooling and when heating.

# PRO-HT Tank Series for ECOi



## PRO-HT TANK

### PRO-HT Tank DHW

PRO-HT Tank		PAW-VP750LDHW-1	PAW-VP1000LDHW-1
Outdoor unit		U-16MF3E8	U-16MF3E8
Volume	L	726	933
Height	H x W	1855 x 990	2210 x 990
Connections to the water supply network		1 1/4"	1 1/4"
Net weight / with water	kg	179 / 929	191 / 1121
Nominal electrical power	kW	5,12	6,14
Reference tapping cycle		2XL	2XL
Energy consumption by chosen cycle A7 / W10-55	kWh	4,14	5,10
Energy consumption by chosen cycle A15 / W10-55	kWh	3,50	4,61
COP DHW (A7 / W10-55) EN 16147 <sup>1)</sup>		5,29	4,81
COP DHW (A15 / W10-55) EN 16147 <sup>2)</sup>		7,01	5,32
Standby input power according to EN16147	W/h	77	80
Sound pressure at 1 m	dB(A)	52	52
Quantity of refrigerant	Kg	8,3	8,3
Average insulation thickness	mm	100	100
Heat exchanger connection for inlet / outlet	Inch (mm)	1/2(12,70) / 3/4(19,05)	1/2(12,70) / 3/4(19,05)
Maximum power consumption without heater	kWh	20,4	20,4
Maximum power consumption with heater	kWh	26,4	26,4
Number of electrical heaters x power	W	1 x 6000	1 x 6000
Voltage / Frequency	V / Hz	400 / 50	400 / 50
Electrical fuse rating	A	16	16
Moisture protection		IP24	IP24
Maximum pipe length	m	50	50
Elevation difference (in/out)	m	30/30	30/30
Operating range - outdoor temperature	°C	-20 ~ +35	-20 ~ +35
Maximum water temperature (heat pump)	°C	65	65
Maximum water temperature (electrical heater)	°C	85	85
Refrigerant (R410A) / CO <sub>2</sub> Eq.	kg / T	8,3 / 17,1	8,3 / 17,1

#### Accessories

<b>PAW-VP-RTC5B-VRF</b>	Tank Controller for ECOi system
<b>PAW-VP-VALV-160</b>	Expansion valve kit 16 kW

#### Accessories

<b>PAW-VP-VALV-280</b>	Expansion valve kit 28 kW
------------------------	---------------------------

1) Heating of sanitary water up to 55 °C with inlet air temperature at 7 °C, humidity at 89 % and inlet water temperature at 10 °C. According to EN16147. 2) Heating of sanitary water up to 55 °C with inlet air temperature at 15 °C, humidity at 74 % and inlet water temperature at 10 °C. According to EN16147.

This product is designed to meet the European Drinking Directive 98/83/EC amended by 2015/1787/EU. The lifespan of the product is not guaranteed in the case of the use of groundwater, such as spring water or well water, the use of tap water when salt or other impurities are contained, nor in areas of acidic water quality. Maintenance and warranty costs related to these cases are the customer's responsibility.  
\* When connected as pressurised, safety valve is mandatory.



### Solution example DHW tank 1000L + ECOi 3-Pipe mixed system

- Ideal offer for hotel projects
- DHW production under spontaneous heating and cooling
- Hot water up to 65 °C is efficiently produced by heat recovery
- A7 COP 6,7 considering heat recovery

### One by one system compatible list with ECOi

Model	Tank type	Product compatibility	Hot water outlet temperature
<b>PAW-VP750LDHW-1</b>	DHW	U-16MF3 (3-Pipe)	65 °C
<b>PAW-VP1000LDHW-1</b>	DHW	U-16MF3 (3-Pipe)	65 °C

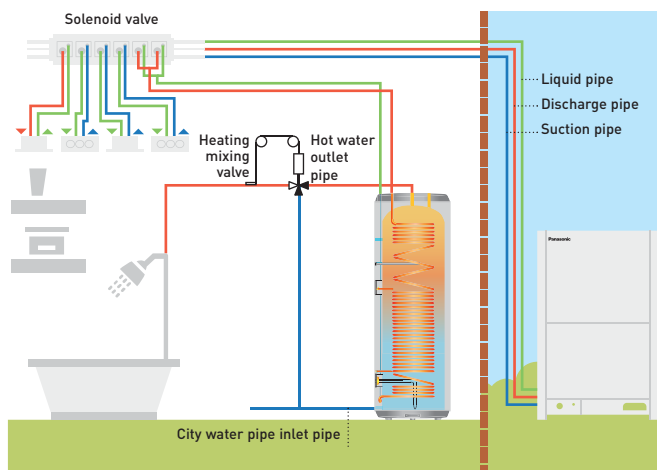

# BMS interface with P-Link

BMS interface with Panasonic communication bus helps you to get significant savings.

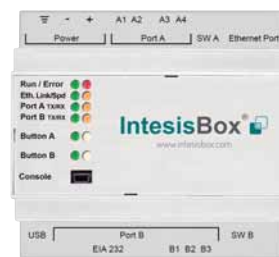

## 1 Direct connection to P-Communication bus

- No need for additional gateway (CZ-CFUNC2)
- Significant 50 % cost saving for BMS interface\*
- Avoid mistakes and reduce configuration time.

\* In the case of PAW-AC2-BAC-16P by Panasonic calculation.

## 2 Upgraded specifications and easy configuration

- Base PCB board with MCU, Ethernet, RS485, RS232 & USB
- Configuration by IP or USB
- New single configuration tool for all models (IntesisBox MAPS)
- Modular expansion PCBs (KNX, RS485, DALI, MBUS, LON, ANYBUS)

## 3 BTL certified for BACnet

- BACnet: Version 14 and BTL certified

### Direct connection to P-Communication bus

The interface can provide faster, cheaper, easier solution in your projects!

Conventional interface.

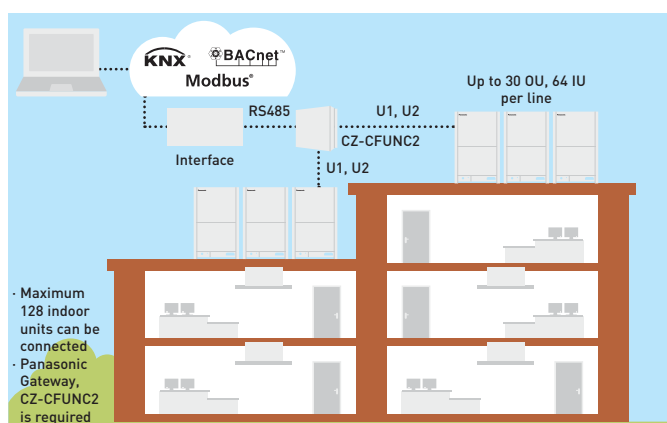

Interface with P-communication bus.

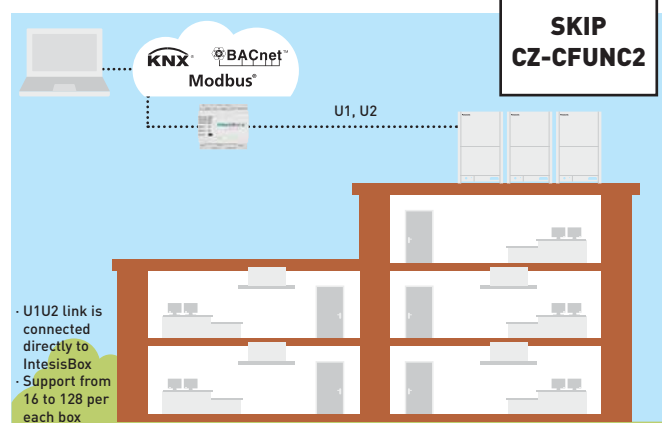

### Upgraded specifications and easy configuration

- Base PCB board with MCU, Ethernet, RS485, RS232 and USB
- Modular expansion PCBs (KNX, RS485, DALI, MBUS, LON, ANYBUS)
- Frontal PCB with all LEDs, buttons and USB console Port
- New single configuration tool for all models (IntesisBox MAPS)

- Improved version of the current communication Stacks, BTL and KNX Certifications will be possible
- Recovery of current configuration project working in V6
- Local logging of interface data via USB without the need for a PC
- Configuration by IP or USB (old generation RS232)
- CB Certification for EU, US, CA and AU. Also UL marked product

PAW-AC2-BAC-16P	BACnet Interface for 16 indoors
PAW-AC2-BAC-64P	BACnet Interface for 64 indoors
PAW-AC2-BAC-128P	BACnet Interface for 128 indoors

PAW-AC2-MBS-16P	Modbus Interface 16 indoor units
PAW-AC2-MBS-64P	Modbus Interface 64 indoor units
PAW-AC2-MBS-128P	Modbus Interface 128 indoor units

PAW-AC2-KNX-16P	KNX Interface for 16 indoors
PAW-AC2-KNX-64P	KNX Interface for 64 indoors

# Smart fan coils

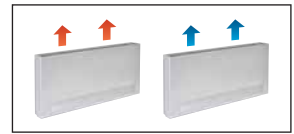

Air flow	Speed	PAW-AAIR-200-2			PAW-AAIR-700-2			PAW-AAIR-900-2		
		Min	Med	Max	Min	Med	Max	Min	Med	Max
<b>Heating mode</b>										
Total heating capacity	W	217,00	470,00	570,00	708,00	1032,00	1188,00	886,00	1420,00	1703,00
Water flow	kg/h	37,30	80,80	98,00	121,80	177,50	204,30	152,40	244,20	292,90
Water pressure drop	kPa	0,40	2,00	2,90	0,30	0,80	1,00	0,50	1,60	2,20
Inlet water temperature	°C	35	35	35	35	35	35	35	35	35
Outlet water temperature	°C	30	30	30	30	30	30	30	30	30
Inlet air temperature	°C	19,00	19,00	19,00	19,00	19,00	19,00	19,00	19,00	19,00
Outlet air temperature	°C	38,90	32,00	30,00	33,30	31,80	30,60	30,20	31,10	30,60
<b>Cooling mode</b>										
Total cooling capacity	W	237,00	345,00	555,00	756,00	1039,00	1204,00	1153,00	1518,00	1746,00
Sensible cooling capacity	W	230,00	314,00	504,00	646,00	903,00	1058,00	1061,00	1384,00	1598,00
Water flow	kg/h	40,00	59,00	95,00	129,00	178,00	207,00	198,00	261,00	300,00
Water pressure drop	kPa	0,40	2,00	2,90	1,00	2,00	2,00	6,00	9,00	12,00
Inlet water temperature	°C	10	10	10	10	10	10	10	10	10
Outlet water temperature	°C	15	15	15	15	15	15	15	15	15
Inlet air temperature	°C	27,00	27,00	27,00	27,00	27,00	27,00	27,00	27,00	27,00
Outlet air temperature	°C	15,00	17,00	18,00	14,00	16,00	17,00	16,00	17,00	18,00
Relative humidity of inlet air	%	47	47	47	47	47	47	47	47	47
Air flow	m <sup>3</sup> /min	0,90	1,90	2,70	2,60	4,20	5,30	4,10	6,10	7,70
Maximum input power	W	7,00	9,00	13,00	14,00	18,00	22,00	16,00	20,00	24,00
Sound pressure	dB(A)	23	33	40	24	36	42	25	36	44
Dimension (HxWxD)	mm	735 x 579 x 129			935 x 579 x 129			1135 x 579 x 129		
Net weight	kg	17			20			23		
3 Ways valve included		Yes			Yes			Yes		
Touch screen thermostat		Yes			Yes			Yes		

**Accessories**  
**PAW-AAIR-LEGS-1** Kits of 2 legs to protect the water pipings

**Accessories**  
**PAW-AAIR-RHCABLE** Motor connection cable for units with hydraulic connections on the right

\* Smart fan coils is produced by Innova.

## Stylish Floor-standing fan coils with advanced controller

The slimline of Smart fan coils delivers high efficiency climate control.

With a depth of just under 13cm they are at the cutting edge of the market. Blending easily into the home, Smart fan coil's elegant design and product refinements are clear to see in every detail.

Exceptional ventilation efficiency means the motor uses considerably less energy (low wattage). The fan speed is continuously modulated by the temperature controller with proportional integral logic, with undoubted advantages for regulating the temperature and humidity in summer mode.

With standard cast radiators.

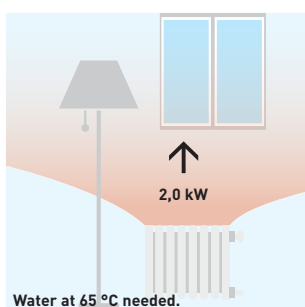

With Smart fan coil.

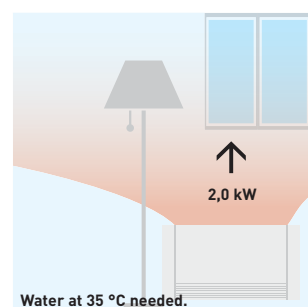

### Technical focus:

- High heating capacity
- 4 operation modes (auto, silent, night-time and maximum ventilation speed)
- Exclusive design
- Extremely compact (only 12,9cm deep)
- Cooling and dehumidification functions possible (drain is needed)
- 3-way valve included (no overflow valve needed on the installation if more than 3 units installed)
- Touch screen thermostat

All temperature curves and capacity are available on [www.panasonicproclub.com](http://www.panasonicproclub.com)

## Fan coils



**PAW-FC-903TC**  
Optional Controller.  
Wired remote controller.



**PAW-FC-RC1**  
Optional Controller.  
Advanced wired remote controller.

Compact units											High Static Pressure
Left side connection			PAW-FC-D11-1	PAW-FC-D15-1	PAW-FC-D24-1	PAW-FC-D28-1	PAW-FC-D40-1	PAW-FC-D55-1	PAW-FC-D65-1	PAW-FC-D90-1	PAW-FC-H150
Right side connection			PAW-FC-D11-1-R	PAW-FC-D15-1-R	PAW-FC-D24-1-R	PAW-FC-D28-1-R	PAW-FC-D40-1-R	PAW-FC-D55-1-R	PAW-FC-D65-1-R	PAW-FC-D90-1-R	PAW-FC-H150-R
Total cooling capacity <sup>1)</sup>	Med/S-Hi	kW	1,0/1,5	1,2/1,7	2,0/2,5	2,4/3,2	3,2/4,6	4,6/5,8	6,1/7,3	6,1/8,1	11,9/14,8
Sensible cooling capacity <sup>1)</sup>	Med/S-Hi	kW	0,8/1,1	0,9/1,3	1,5/1,9	1,8/2,3	2,2/3,3	3,3/4,5	4,3/5,1	4,6/6,3	9,6/12,9
Heating capacity <sup>1)</sup>	Med/S-Hi	kW	1,4/2,0	1,5/2,2	2,4/3,1	2,9/4,0	4,1/5,7	5,3/7,1	7,9/9,3	8,1/11,6	14,9/19,9
Power consumption	S-Lo/Med/S-Hi	W	13/24/36	10/18/29	16/37/45	15/37/56	28/55/72	37/75/105	53/100/147	90/112/188	180/421/675
Fuse rating	A		2	2	2	2	2	2	2	2	6
Dimensions <sup>2)</sup>	H x W x D	mm	220x570x430	220x570x430	220x753x430	220x938x430	220x1122x430	220x1307x430	220x1121x530	220x1316x530	376x1600x798
Weight <sup>3)</sup>	kg		13	13	15	20	22	26	27	38	63
Sound power global	S-Lo/Med/S-Hi	dB(A)	33/40/49	31/43/50	30/45/52	30/44/51	34/46/56	38/51/58	43/56/61	50/55/64	52/64/71
Sound pressure global	S-Lo/Med/S-Hi	dB(A)	24/31/40	22/34/41	21/36/43	21/35/42	25/37/47	29/42/49	34/47/52	41/46/55	31/45/51
Static pressure	Max	Pa	30	30	50	50	70	70	70	70	110
Air flow <sup>1)</sup>	Med/S-Hi	m <sup>3</sup> /h	190/283	179/265	274/390	357/499	486/716	640/933	893/1064	936/1397	2112/3176
Water pressure drop	Med/S-Hi	kPa	19,5/39,2	3,9/6,3	19,3/28,8	17,1/28	22,8/46,9	37,4/60,2	15,4/21,5	19,3/32,5	19,8/26,1
Fan speeds			3 speeds	3 speeds	3 speeds	3 speeds	3 speeds	3 speeds	3 speeds	3 speeds	3 speeds
Fan motor and number of speeds			AC 5 speeds	AC 5 speeds	AC 5 speeds	AC 5 speeds	AC 5 speeds	AC 5 speeds	AC 5 speeds	AC 5 speeds	AC 5 speeds
Drain pan and air filter			Included	Included	Included	Included	Included	Included	Included	Included	Included
Water connections	Inch		1/2	1/2	1/2	1/2	1/2	1/2	3/4	3/4	1

### Accessories

<b>PAW-FC-RC1</b>	Advanced wired remote controller for fan coil
<b>PAW-FC-903TC</b>	<b>NEW</b> Wired remote controller for fan coil
<b>PAW-FC-2WY-11/55-1</b>	2 way valve + drain pan (for PAW-FC-D11/15/24/28/40/55-1)
<b>PAW-FC-2WY-65/90-1</b>	2 way valve + drain pan (for PAW-FC-D65/90-1)

### Accessories

<b>PAW-FC-2WY-150</b>	2 way valve + drain pan (for PAW-FC-H150)
<b>PAW-FC-3WY-11/55-1</b>	3 way valve + drain pan (for PAW-FC-D11/15/24/28/40/55-1)
<b>PAW-FC-3WY-65/90-1</b>	3 way valve + drain pan (for PAW-FC-D65/90-1)
<b>PAW-FC-3WY-150</b>	3 way valve + drain pan (for PAW-FC-H150)

<sup>1)</sup> Air flow and capacity at 0 Pa of static pressure. <sup>2)</sup> Including pan and electrical box. <sup>3)</sup> Without water content. \* Performances based on: Cooling: Air: 27 °C DB / 19 °C WB, Chilled water: 7 °C / 12 °C - Heating: Air: 20 °C DB, Hot water: 50 °C / 45 °C. \*\* Fan coil units are produced by Systemair.

### Range of fan coil units

Easy to install, improved sound level and performance. The fan coil range consists of a compact ducted range ideal for residential and commercial use and one model with high static pressure for commercial applications. All units are certified by Eurovent, include drain pan and filter and are equipped with a low consumption fan motor. The D type is even more flexible thanks to an L-shaped drain pan. The unit can be installed either in a horizontal or in a vertical position.

**1** Innovation for an optimum comfort

**3** Efficient high-quality coil

**2** Low energy consumption fan

**4** Flexible installation: vertical or horizontal

### Fan coil controller PAW-FC-RC1

This advanced controller provides a higher level of comfort in heating. The sensor can be used as a water flow sensor, stopping the fan when the water temperature is low, avoiding cold drafts in winter. Also is ready to use J Generation feature of defrost mode and stop the fan coil.

#### Features:

- Room thermostat
- 3 outputs, 230 V relays for fan control
- 2 outputs, 230 V relays for heating / cooling control
- Modbus RTU slave
- 1 DI for presence detection (key card switch)
- 1 AI for sensor

# Leak detection and automatic refrigerant pump down



## Improving safety and the environment

Panasonic has developed an innovative solution to detect refrigerant leaks that offer complete assurance and protection for end users, building occupiers and the environment. Panasonic's Pump Down System is ideal for hotels, offices and public buildings where safety for occupants and the building owners is of utmost importance.

The system monitors refrigerant leakage continually and provides a warning before refrigerant leaks, preventing major refrigerant loss and potentially damaging the system's efficiency. The new system can improve potential refrigerant loss to approximately 90 %.

As well as ensuring safe and reliable operation, Panasonic's Pump Down System contributes to a building qualifying for additional BREEAM points and enables compliance with current EN378 2008 standards, covering applications where refrigeration concentration levels exceed practical safety limits of 0,44 kg/m<sup>3</sup>.

Panasonic has developed two detection methods that can operate simultaneously to offer complete protection for owners, building occupiers and the environment.

## Pump Down system

**This innovative pump down system can be connected in two ways:**

- With sensor leakage
- Without sensor leakage, using only an innovative algorithm

### Basic pump down function:

- Detect the leakage
- Activate pump down process
- Collect the gas in the tank
- Close the valves to isolate the gas

### Key points:

- Comply with legislation
- Protect personnel
- Protect the environment
- Save on operating costs



Panasonic offers a purposely engineered solution which allows for a quick and simple installation. The unit contains 5 actuating ball valves, a 30l storage vessel and PLC all housed in an IP54 rated container. Terminals on the front of the unit allow for easy wiring to the alarm terminal, Hi / Lo pressure transducers and discharge temperature sensor(s) of the condensing unit(s).

## R22 Renewal

Panasonic's advanced technology enables the system to work with previously installed pipe work by managing the working pressure within the system down to R22 (33 bar) levels, this ensures the system works safely and efficiently without loss of capacity.

The new equipment can offer increased COP/EER by using state of the art inverter compressor and heat exchanger technology.

Having contacted your Panasonic supplier regarding pipe work restrictions and gained approval to use the

Panasonic Renewal System there are three main tests that have to be carried out to ensure that the system can be used effectively. Firstly a thorough inspection of the pipe work must be carried out and any damage must be repaired. Secondly an oil test has to be carried out to ensure that the system has not been subject to a compressor burnout during its lifetime. Lastly a VRF Renewal Kit (CZ-SLK2) has to be installed within the pipe work to ensure that the system is cleaned of any remnants of oil.





# Design Support Software for VRF



Features the unique Mounting Scheme function providing more thorough spec-in and tender quotation support for easier, faster completion of work

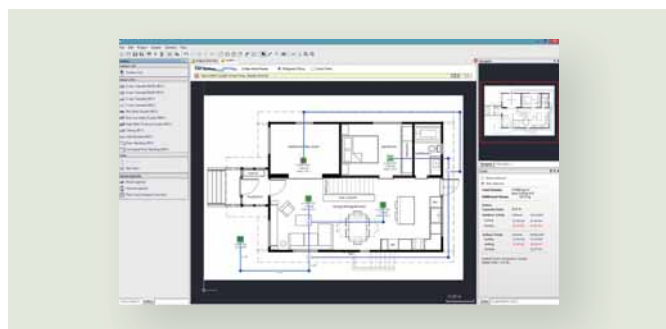

**The Panasonic VRF Designer software can be used for all Panasonic VRF ME2, LE and MF3.**

Panasonic has identified the importance of ever-increasing demands for fast and accurate responses to customer requests in our industry. More and more emphasis is being placed upon energy-efficiency in our marketplace. The ability to calculate cooling/heating loads and produce information of actual design conditions is a major advantage to any architect, consultant, contractor or end user.

Panasonic understands the time-poor and demanding industry we are in and we are pleased to announce the launch of the next generation of our system design software program.

The Panasonic VRF Designer software has been customised to make the selection and design process as quick and easy as possible.

The design package utilises system wizards and import tools to enable both simple and complex systems to be created. In addition, the system will allow outdoor and indoor units to be dragged on an interactive desktop. This allows users to create everything from realistic floor plans with detailed piping and wiring schematics to send out with quotations, through to installation guidance drawings.

#### Features include:

- Mounting scheme. Design selection from building floor drawing
- Any kind of drawing format. (dxf, jpg, png..etc.)
- Conventional principal scheme
- Easy to use system wizards
- Auto piping and wiring features
- Converted duties for conditions and pipework
- Auto(CAD) (dxf), Excel and PDF export
- Detailed wiring and pipework diagrams
- Automatic price quotation
- Automatic tender document assist
- SEER, SCOP
- ESEER

**Panasonic's Advanced VRF software with AutoCAD® compatibility makes design easier than ever**

Panasonic provides bespoke software helping system designers, installers and dealers to very quickly design and size systems, create wiring diagrams and issue bills of quantities at the push of a button.



#### Panasonic VRF Service Checker

Panasonic will make available to installers and commissioning companies the VRF Service Checker as a communication interface to Panasonic VRF systems. This easy to manage tool checks all parameters of the system.

#### The VRF Service Checker allows:

- On ECOi and Mini ECOi connect anywhere on the P-Link
- Search the P-Link to validate systems that are connected
- Monitor all indoor and outdoor units simultaneously on 1 screen
- Monitor all Temperature data, Pressure data, Valve position, and alarm status on 1 screen
- Data can be viewed in Graph or number format
- Controlling the indoor unit ON/OFF, MODE, SET POINT, FAN, and TEST mode
- Switching between various systems on same communication P-Link (ECOi only)
- Monitor and record at a set interval time
- Record and review the data at a later date
- Update software as ROM flash writer

This Panasonic VRF Service Checker is available from your service partner.

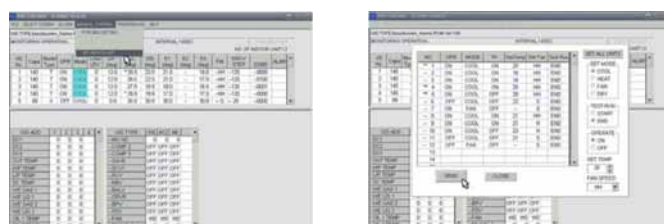

Interface Box

# Control and Connectivity

A wide variety of control options to meet the requirements of different applications.

## Centralized control systems

### BMS system. PC base.



**CZ-CSWKC2**  
P-AIMS. Basic software.  
Up to 1024 groups. Controls 1024 units.

### Connection with 3rd party controller.



**CZ-CAPDC2**  
Seri-Para I/O unit  
for outdoor unit.  
Up to 4 outdoor units.



**CZ-CAPC3**  
ON/OFF control for  
external devices such  
as ERV.  
Controls 1 unit.



**CZ-CAPBC2**  
Mini Seri-Para I/O Unit  
0 - 10V.  
Controls 1 indoor unit or a  
group of 8 indoor units.



**CZ-CFUNC2**  
Communication  
Adaptor.  
Up to 128 groups.  
Controls 128 units.

### AC Smart Cloud.



**CZ-CFUSCC1**  
Cloud internet control.  
Up to 128 groups. Controls 128 units.

## Domestic integration to P-Link - CZ-CAPRA1

Can connect RAC range to P-Link. Full control is now possible.

### Integrates any unit in big system control.

- TKEA / PKEA server room integration
- Small offices with domestic indoors
- Tender for refurbishment (old system domestic and VRF in one installation)

<p>Centralized control systems: 64 indoor units</p>	<p>Intelligent controller / Web server: 256 indoor units</p>	<p>P-AIMS: 1024 indoor units</p>
---	--	----------------------------------

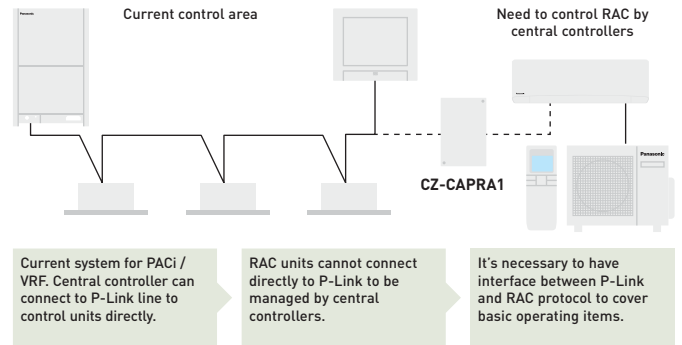

**Basic operation items:** ON/OFF, Mode select, Temperature setting, Fan speed, Flap setting, Remote control prohibit.

**External input:** ON/OFF control signal, Abnormal stop signal.

**External output for Relay <sup>1)</sup>:** Operation status (ON/OFF), Alarm status output.







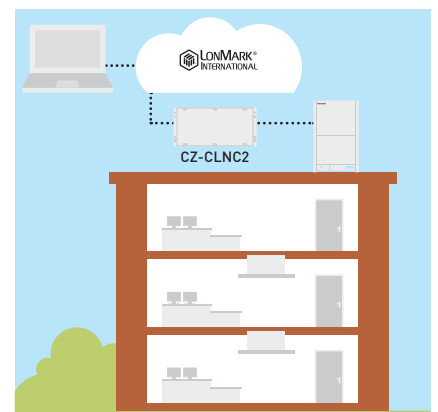
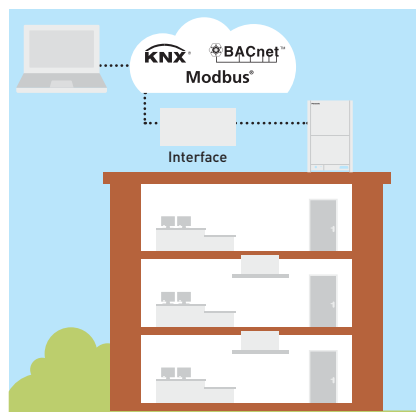

1) Because current CN-CNT connector can not provide the power for external output relay, additional Input power for external relay is necessary.

## Easy connection to KNX, Modbus, LonWorks and BACnet

Great flexibility for integration into your KNX / Modbus / LonWorks / BACnet projects allows fully bi-directional monitoring and control of all the functioning parameters.

For more information, contact Panasonic.



			Econavi control	Built-in thermostat	Indoor units which can be controlled	Use limitations	Function ON/OFF	Mode setting	Fan speed setting	Temperature setting	Air flow direction	Permit/Prohibit switching	Weekly program	BMS protocol
<b>Individual controllers</b>														
Touch room controller for hotel with Dry Contacts		<b>PAW-RE2C4-MOD-WH</b> <b>PAW-RE2C4-MOD-BK</b> WH: White, BK: Black. Bespoke finish available on request.	—	✓	1 indoor unit	—	✓	✓	✓	✓	—	✓	—	Modbus + 4 digital I/O signals
Touch display control for hotel with Dry Contacts		<b>PAW-RE2D4-WH</b> <b>PAW-RE2D4-BK</b> WH: White, BK: Black. Bespoke finish available on request.	—	✓	1 indoor unit	—	✓	✓	✓	✓	—	✓	—	Stand Alone + 2 digital inputs
Design wired remote controller		<b>CZ-RTC5B</b>	✓	✓	1 group, 8 units	· Up to 2 controllers can be connected per group	✓	✓	✓	✓	✓	—	✓	—
Wired remote controller		<b>CZ-RTC6</b> Non-wireless	✓	✓	1 group, 8 units	· Up to 2 controllers can be connected per group	✓	✓	✓	✓	✓	—	—	—
		<b>CZ-RTC6BL</b> With Bluetooth®	✓	✓	1 group, 8 units	· Up to 1 controller can be connected per group	✓	✓	✓	✓	✓	—	✓	—
Wired remote controller		<b>CZ-RTC2</b> For Floor-standing (MP1) indoor units	—	✓	1 group, 8 units	· Up to 2 controllers can be connected per group	✓	✓	✓	✓	✓	—	✓	—
Infrared remote controller		<b>CZ-RWS3 + CZ-RWRU3W</b> <b>CZ-RWS3</b> <b>CZ-RWS3 + CZ-RWRL3</b> <b>CZ-RWS3 + CZ-RWRD3</b> <b>CZ-RWS3 + CZ-RWRT3</b> <b>CZ-RWS3 + CZ-RWRC3</b>	✓	—	1 group, 8 units	· Up to 2 controllers can be connected per group	✓	✓	✓	✓	✓ <sup>1)</sup>	—	—	—
<b>Centralized controllers</b>														
Central controller with weekly timer		<b>CZ-64ESMC3</b>	✓	—	64 groups, maximum 64 units	· Up to 10 controllers, can be connected to one system · Main unit/sub unit (1 main unit + 1 sub unit) connection is possible · Use without remote controller is possible	✓	✓	✓	✓	✓ <sup>1)</sup>	✓	✓	—
Only ON/OFF operation from central station. ON/OFF controller		<b>CZ-ANC3</b>	—	—	16 groups, maximum 64 units	· Up to 8 controllers (4 main units + 4 sub units) can be connected to one system · Use without remote controller is impossible	✓	—	—	—	—	✓	—	—
Intelligent controller (touch screen panel)		<b>CZ-256ESMC3</b>	✓	—	Main unit: 128. Up to 256 units can be expanded	· Communication adaptor CZ-CFUNC2 is necessary for connection with more than 128 units	✓	✓	✓	✓	✓ <sup>1)</sup>	✓	✓	—

1. Setting is not possible when a remote controller unit is present (use the remote controller for setting). \* All specifications subject to change without notice.

# VRF Smart Connectivity+

The future of Control.



VRF Smart Connectivity+ offers efficient energy management and a new air conditioning control solution with high IAQ (Indoor Air Quality).

- Energy Management System for Rooms**
- Management System for the Entire Building**

Each room is monitored by high-precision sensors, making it possible to make every room's temperature comfortable without wasting energy.

A Building Energy Management System (BEMS) can also be connected for Plug & Play centralised control of the building's entire energy consumption.

## Connect to the future. VRF Smart Connectivity+

Through thorough energy management, Panasonic's VRF Smart Connectivity+ is a completely new, state-of-the-art solution providing energy saving and comfort as well as simple installation, operation and running.

Panasonic, passionately pursuing the ultimate in energy saving through the application of cutting-edge technology, and Schneider Electric, an advanced global energy management specialist offering innovative control systems. This collaboration has set the new standard for creating the next generation of contemporary buildings.

## Smart connectivity devices

	<b>SED-WDC-G-5045</b> Door/window sensor.		<b>SED-MTH-G-5045</b> Wall/ceiling motion/temperature/humidity sensor.
	<b>SED-CO2-G-5045</b> CO <sub>2</sub> , temperature/humidity sensor.		<b>SED-WLS-G-5045</b> Water leakage sensor.

ZigBee communication card VCM

\* With optional VCM communication card.

Schneider Electric brand - SE8000

## Features

- Up to 5-year battery life batteries included
- Battery life of CO<sub>2</sub> sensor up to 10-year.
- Battery level is a data point
- Sensor points visible when SE8000 is integrated via BACnet MS/TP
- Sensor status and battery level visible when SE8150 is integrated via ZigBee® Pro
- Integration to BMS only recommended when each MPM is connected to Ethernet and set as a ZigBee® Coordinator node

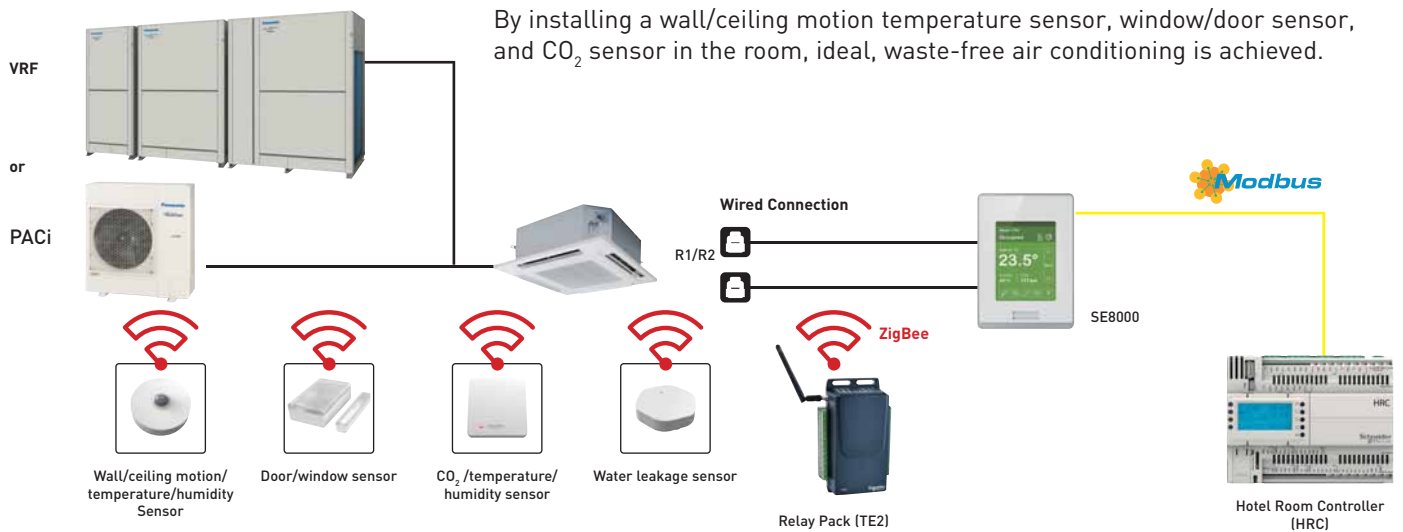

### Sensing & Control technology

Using sensors from Schneider Electric, high-quality occupancy control and automatic IAQ control are realised. The sensors detect the presence or absence of occupants, and the opening and closing of doors and windows to achieve the most efficient energy management for exceptional air-conditioned comfort. Flexible installation is possible to match different applications and building features such as walls, ceilings and proximity to doors and windows. No wiring means extra installation versatility.

Batteries last for up to five years (10-year battery for CO<sub>2</sub> sensor) and are easy to install and replace.

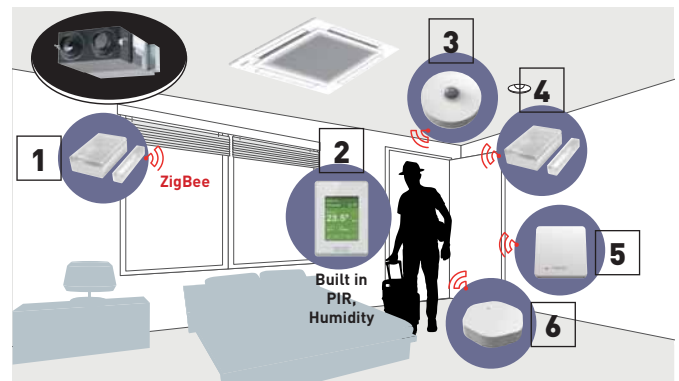

1. Window sensor (option).
2. Room controller.
3. Ceiling motion sensor (option).
4. Door sensor (option).
5. CO<sub>2</sub> sensor (option).
6. Water leakage sensor (option).

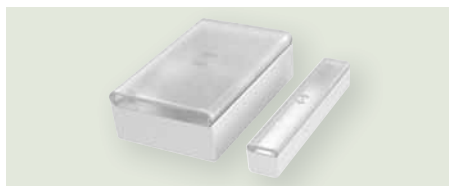

**Door/window sensor.**  
Door and window contact detection sensor to monitor opening and closing.

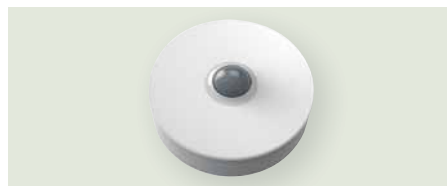

**Wall/ceiling motion/temperature/humidity sensor.**  
Wall and ceiling sensor to detect the presence or absence of occupants.



**CO<sub>2</sub>/temperature/humidity sensor.**  
Monitor indoor air quality, review data on interfacing devices, and control fresh air inside customisable zones.



**Water leakage sensor.**  
Two sensing pads under the body activate when water is present between the two pads. Detecting the water, the sensor reports the event to the controller (and BEMS).



**Relay Pack (TE2).**  
Wireless programmable terminal equipment controllers for HVAC equipment and pulse counting. Includes local memory to store fail safe control sequence.



**Hotel Room Controller (HRC).**  
The Hotel Room Controller controls connected guest room devices and aggregates data, making it visible to guest room and property management systems.

# Accessories and control

## Distribution joint kits

### CZ-P680PH2BM

ECOi 2-Pipe for outdoor unit (68,0 kW or less).

### CZ-P1350PH2BM

ECOi 2-Pipe for outdoor unit (more than 68,0 kW).

### CZ-P224BK2BM

ECOi 2-Pipe for indoor unit (22,4 kW or less\*).

### CZ-P680BK2BM

ECOi 2-Pipe for indoor unit (68,0 kW or less\*).

### CZ-P1350BK2BM

ECOi 2-Pipe for indoor unit (more than 68,0 kW\*).

### CZ-P680PJ2BM

ECOi 3-Pipe for outdoor unit (68,0 kW or less).

### CZ-P1350PJ2BM

ECOi 3-Pipe for outdoor unit (greater than 68,0 kW and no more than 135,0 kW).

### CZ-P224BH2BM

ECOi 3-Pipe for indoor unit (22,4 kW or less).

### CZ-P680BH2BM

ECOi 3-Pipe for indoor unit (greater than 22,4 kW and no more than 68,0 kW).

### CZ-P1350BH2BM

ECOi 3-Pipe for indoor unit (greater than 68,0 kW and no more than 135,0 kW).

### CZ-P160BK2BM

ECOi 2-Pipe and Mini ECOi for indoor unit (22,4 kW or less\*).

### CZ-P4HP3C2BM

3-Pipe header pipe.

\* In case the total capacity of indoor units connected after distribution exceeds the total capacity of the outdoor units, select the distribution piping size for the total capacity of the outdoor units.

## Heat Recovery Box

### KIT-P56HR3

Heat recovery box (up to 5,6 kW) [CZ-P56HR3 + CZ-CAPE2].

### KIT-P160HR3

Box recovery kit (from 5,6 kW to 16,0 kW). [CZ-P160HR3 + CZ-CAPE2].



### CZ-P56HR3

Heat recovery box (up to 5,6 kW).



### CZ-CAPE2

Heat recovery PCB.

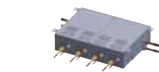

### CZ-P456HR3

4 ports 3 pipe box (up to 5,6 kW per port).



### CZ-P656HR3

6 ports 3 pipe box (up to 5,6 kW per port).

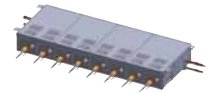

### CZ-P856HR3

8 ports 3 pipe box (up to 5,6 kW per port).

### CZ-P160HR3

Solenoid valve kit (from 5,6 kW to 16,0 kW).

### CZ-CAPEK2

3-Pipe control PCB for Wall-mounted.

### CZ-P4160HR3

4 ports 3 pipe box (up to 16,0 kW per port).

### CZ-P160RVK2

Rap valve kit.

## Plenums



### CZ-DUMPA56MF2

Air Inlet Plenum for S...MF2E5A 15, 22, 28, 36, 45 & 56.



### CZ-DUMPA90MF2

Air Inlet Plenum for S...MF2E5A 60, 73 & 90.

### CZ-DUMPA160MF2

Air Inlet Plenum for S...MF2E5A 106, 140 & 160.

### CZ-DUMPA22MMR2

Air Inlet Plenum for S...MM1E5A 22, 28 & 36.

### CZ-DUMPA22MMR3

Air Inlet Plenum for S...MM1E5A 45 & 56.

### CZ-DUMPA22MMS2

Air Outlet Plenum for S...MM1E5A 22, 28 & 36.

### CZ-DUMPA45MMS3

Air Outlet Plenum for S...MM1E5A 45 & 56.

### CZ-TREMIESPW706

Air Outlet Plenum for S-224ME1E5A / S-280ME1E5.

## Wall-mounted external valve



### CZ-P56SVK2

External valve (model sizes 15 to 56).

### CZ-P160SVK2

External valve (model sizes 73 to 106).

## Other Accessory



### CZ-CNEXU1

nanoe™ X device for 4 Way 90x90 Cassette.



### CZ-CENSC1

Econavi energy savings sensor.



### CZ-CSRC3

Remote temperature sensor.

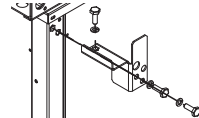

### PAW-3WSK

Stacking kit for vertically stacking up to 3 WHE (4 pieces per Kit).

## PRO-HT Tank accessories

### PAW-VP-RTC5B-VRF

Tank Controller for ECOi system.

### PAW-VP-VALV-160

Expansion valve kit 16 kW.

### PAW-VP-VALV-280

Expansion valve kit 28 kW.

## Smart fan coil accessories

### PAW-AAIR-LEGS-1

Kits of 2 legs to protect the water pipings.

### PAW-AAIR-RHCABLE

Motor connection cable for units with hydraulic connections on the right.

## Fan coil accessories



### PAW-FC-903TC

**NEW** Wired remote controller for fan coil.



### PAW-FC-RC1

Advanced wired remote controller for fan coil.

### PAW-FC-2WY-11/55-1

2 way valve + drain pan (for PAW-FC-D11/15/24/28/40/55-1).

### PAW-FC-2WY-65/90-1

2 way valve + drain pan (for PAW-FC-D65/90-1).

### PAW-FC-2WY-150

2 way valve + drain pan (for PAW-FC-H150).

### PAW-FC-3WY-11/55-1

3 way valve + drain pan (for PAW-FC-D11/15/24/28/40/55-1).

### PAW-FC-3WY-65/90-1

3 way valve + drain pan (for PAW-FC-D65/90-1).

### PAW-FC-3WY-150

3 way valve + drain pan (for PAW-FC-H150).

Panels



**CZ-KPU3W**  
Standard panel for 4 Way 90x90 Cassette.



**CZ-KPU3AW**  
Econavi panel for 4 Way 90x90 Cassette.



**CZ-KPY3AW**  
Panel for 4 Way 60x60 Cassette size 700x700 mm.



**CZ-02KPL2**  
Panel for 2 Way Cassette (for S-22 to S-56 models).



**CZ-03KPL2**  
Panel for 2 Way Cassette (for S-73 models).



**CZ-KPD2**  
Panel for 1 Way Cassette.

**CZ-KPY3BW**

Panel for 4 Way 60x60 Cassette size 625x625 mm.

VRF Smart Connectivity+



**SER8150R0B1194**  
Remote Controller Panasonic Net Con, RH, No PIR, R1/R2.

**SER8150R5B1194**

Remote Controller Panasonic Net Con, RH, PIR, R1/R2.

**VCM8000V5094P**

Wireless Zigbee Pro module / Green Com card.



**SEC-TEA-R-230-5045**  
Smart Terminal Controller ZigBee Pro High Power, External Antenna, 4UI/4A0/5D0, 220-240 VAC.

**SEC-TEA-R-24-5045**

Smart Terminal Controller ZigBee Pro High Power, External Antenna, 4UI/4A0/5D0, 24 VAC.



**MPM-UN-014-5045**  
Universal network controller with Building Expert and StruXureWare integration, High Power, 6 I/6O, Modbus.

**MPM-RAEC-5045**

Universal network controller Cable extension.



**HRCEP14R**  
Hotel Room Expansion Module 14 indoor units.

**HRCPBG28R**

Hotel Room Controller 28 indoor units.

**HRCPDG42R**

Hotel Room Controller w/Display 42 indoor units.



**SED-WDC-G-5045**  
Door / window wireless sensor.



**SED-MTH-G-5045**  
Wall / ceiling (motion) wireless sensor.



**SED-CO2-G-5045**  
CO<sub>2</sub> sensor.



**SED-TRH-G-5045**  
Sensor with room temperature and humidity.



**SED-WLS-G-5045**  
Water leakage sensor.



**FAS-00**  
Cover frame. Silver.

**FAS-01**  
White.

**FAS-03**  
Glossy translucent white.

**FAS-05**  
Light tan wood.

**FAS-06**  
Dark brown wood.

**FAS-07**  
Dark black wood.

**FAS-10**  
Brushed steel finish.

Controller and touch controllers for Hotels with Dry Contacts

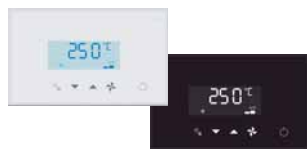

**PAW-RE2C4-MOD-WH**  
Modbus RS-485 touch room controller with I/O, White.

**PAW-RE2C4-MOD-BK**  
Modbus RS-485 touch room controller with I/O, Black.

**PAW-RE2D4-WH**  
Touch display control with 2 digital inputs, White.

**PAW-RE2D4-BK**  
Touch display control with 2 digital inputs, Black.

Hotel sensors for Dry Contacts



**PAW-WMS-DC**  
Wall motion sensor 24 V.

**PAW-WMS-AC**  
Wall motion sensor 240 V AC.



**PAW-CMS-DC**  
Ceiling motion sensor 24 V.

**PAW-CMS-AC**  
Ceiling motion sensor 240 V AC.



**PAW-24DC**  
Power supply 24 V.



**PAW-DWC**  
Door or window contact.

# Accessories and control

## Centralised Controls. BMS System. PC Base



**CZ-CSWKC2**  
PAIMS Basic software.

**CZ-CFUNC2**  
Communication adaptor.



**CZ-CSWAC2**  
PAIMS Consumption calculation control.



**CZ-CSWBC2**  
PAIMS - BACnet interface.



**CZ-CSWGC2**  
PAIMS - Layout display.



**CZ-CSWWC2**  
PAIMS - Web application.

## Panasonic AC Smart Cloud



**CZ-CFUSCC1**  
Panasonic AC Smart Cloud. Cloud internet control. Up to 128 groups. Controls 128 units.

**PAW-MVNOAC-V**  
**PAW-MVNOAC-K**  
3G communication package (SIM Card included). V, K: Depending on countries.

## Centralised Controls. Connection with 3rd Party Controller



**CZ-CAPDC2**  
Serial parallel device controlling outdoor units, up to 4 units.



**CZ-CAPC3**  
Adaptor for ON/OFF control of external devices.



**CZ-CAPBC2**  
Mini series parallel device controlling indoor units, maximum 1 group and 8 indoor unit.



**CZ-CFUNC2**  
Communication Adaptor. Up to 128 groups. Controls 128 units.

## Accessories Interfaces



**CZ-CAPWFC1**  
Commercial Wi-Fi Adaptor.



**PAW-AC2-MBS-16P**  
**PAW-AC2-MBS-64P**  
**PAW-AC2-MBS-128P**  
Modbus Interface for 16, 64 or 128 indoor units.

**PAW-AC2-KNX-16P**  
**PAW-AC2-KNX-64P**  
KNX Interface for 16 or 64 indoor units.

**PAW-AC2-BAC-16P**  
**PAW-AC2-BAC-64P**  
**PAW-AC2-BAC-128P**  
BACnet Interface for 16, 64 or 128 indoor units.



**PAW-RC2-KNX-1i**  
KNX Interface.



**PAW-RC2-MBS-1**  
Modbus Interface.



**PAW-RC2-MBS-4**  
Modbus interface to control 4 indoor/groups.

**PAW-AC-KNX-64**  
KNX Interface for 64 indoor units.

**PAW-AC-KNX-128**  
KNX Interface for 128 indoor units.

**PAW-AC-MBS-64**  
Modbus Interface for 64 indoor units.

**PAW-AC-MBS-128**  
Modbus Interface for 128 indoor units.

**PAW-TM-MBS-RTU-64**  
Modbus Interface for 64 indoor units.

**PAW-TM-MBS-TCP-128**  
Modbus Interface for 128 indoor units.



**PAW-MBS-TCP2RTU**  
ModBus RTU Slave devices.



**PAW-RC2-BAC-1**  
BACnet Interface.

**PAW-AC-BAC-64**  
BACnet Interface for 64 indoor units.

**PAW-AC-BAC-128**  
BACnet Interface for 128 indoor units.



**CZ-CAPRA1**  
RAC interface adapter for integration into P-Link, plus external input and alarm/status output.



**CZ-CLNC2**  
Lonworks® Interface controls up to 16 groups and 64 indoor units.



## Individual Controls



**CZ-RTC6**  
NEW Wired remote controller (non-wireless).

**CZ-RTC6BL**  
NEW Wired remote controller with Bluetooth®.



**CZ-RTC5B**  
Design wired remote controller with Econavi function and datanavi.



**CZ-RTC2**  
Standard wired remote controller for Floor-standing (P1).



**CZ-RWS3 + CZ-RWRU3W**  
Infrared remote controller for 4 Way 90x90 Cassette.



**CZ-RWS3**  
Infrared remote controller for Wall-mounted and 4 Way 60x60 with panel and Floor Console.



**CZ-RWS3 + CZ-RWRL3**  
Infrared remote controller for 2 Way Cassette.



**CZ-RWS3 + CZ-RWRD3**  
Infrared remote controller for 1 Way Cassette.



**CZ-RWS3 + CZ-RWRT3**  
Infrared remote controller for Ceiling.



**CZ-RWS3 + CZ-RWRC3**  
Infrared remote controller for all indoor units.

## Centralised Controls



**CZ-64ESMC3**  
System Controller with Schedule timer. Operation with various function from center station.

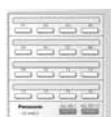

**CZ-ANC3**  
Central ON/OFF controller, up to 16 groups, 64 indoor units.



**CZ-256ESMC3**  
Simplified load distribution ratio (LDR) for each tenant. Intelligent Controller (Touch screen panel).

## Accessories Cables



**CZ-T10**  
Cable for all the T10 functions.



**PAW-FDC**  
Cable to operate external EC fan.



**PAW-OCT**  
Cable for all option monitoring signals.

**PAW-EXCT**  
Cable with force Thermo OFF/leakage Detection.

## Accessories PCB



**PAW-T10**  
T10 interface PCB with digital and relay connections.

**PAW-ECF**  
PCB for fan speed control of external EC Fan.

## R-22 Replacement Kit

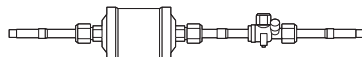

**CZ-SLK2**  
Replacement kit for R-22.

## Pump Down System



**PAW-PUDME1A-1**  
ECOi 2-Pipe Pump down for 1 outdoor unit system.

**PAW-PUDME1A-2**  
ECOi 2-Pipe Pump down for 2 outdoor units system.

**PAW-PUDME1A-3**  
ECOi 2-Pipe Pump down for 3 outdoor units system.

**PAW-PUDMF2A-1**  
ECOi 3-Pipe Pump down for 1 outdoor unit system.

**PAW-PUDMF2A-2**  
ECOi 3-Pipe Pump down for 2 outdoor units system.

**PAW-PUDMF2A-3**  
ECOi 3-Pipe Pump down for 3 outdoor units system.

**PAW-PUDME1A-1R**  
ECOi 2-Pipe Pump down for 1 outdoor unit system + Receiver Kit 30L.

**PAW-PUDME1A-2R**  
ECOi 2-Pipe Pump down for 2 outdoor units system + Receiver Kit 30L.

**PAW-PUDME1A-3R**  
ECOi 2-Pipe Pump down for 3 outdoor units system + Receiver Kit 30L.

**PAW-PUDMF2A-1R**  
ECOi 3-Pipe Pump down for 1 outdoor unit system + Receiver Kit 30L.

**PAW-PUDMF2A-2R**  
ECOi 3-Pipe Pump down for 2 outdoor units system + Receiver Kit 30L.

**PAW-PUDMF2A-3R**  
ECOi 3-Pipe Pump down for 3 outdoor units system + Receiver Kit 30L.

**PAW-PUDRK30L**  
Receiver Kit 30L.



## Discover a new era of ECOi, the ECOi-W. Heat pumps and cooling only chillers

Panasonic introduces the new ECOi-W heat pumps and cooling only chiller series. These new series provides a wide variety of HVAC system solutions, to meet all of your residential, commercial and industrial needs.

## ECOi-W, the solution for hotels, offices and industry.

High seasonal efficiency with the line-up from 20 kW to 210 kW.

Fully customisable design gives high flexibility for commercial applications.



## Quiet operation in full range.

The full range provides very low noise operation thanks to the compressor phonic insulation. The level of quiet operation is outstanding in the market.

## BMS integration.

Modbus RTU is included as standard in full range and additional optional BMS protocols are available for both BACnet and Modbus.



## Panasonic introduces a new heat pump and chiller series named ECOi-W.

Fan coil applications with ECOi-W Chiller system.

## Simple user friendly control.

A control panel with intuitive design is equipped on all ECOi-W systems as standard.



# ECOi-W the solution for hotels, offices and industry



- 1 High energy saving and comfort**
- High SEER/SCOP
  - Quiet operation
  - Integration with ECOi VRF systems via BMS control

- 2 High flexibility**
- Capacity range from 20 kW to 210 kW
  - Customisable design
  - Operating range: -17 °C (heating) to 50 °C (cooling)
  - Wide range of hydraulic options
  - Wide range of communication protocols

- 3 High quality**
- Defrost limiting coil design (140 to 210)
  - Optimized design for service and maintenance
  - Compact footprint

## Operating conditions

Panasonic ECOi-W provides a wide operation range from -17 °C in heating to 50 °C in cooling.

Water outlet temperature in cooling: A uniqueness of ECOi-W, is the water outlet temperature down to -10 °C in cooling. It can ensure the operation temperature of the process equipment in factories.

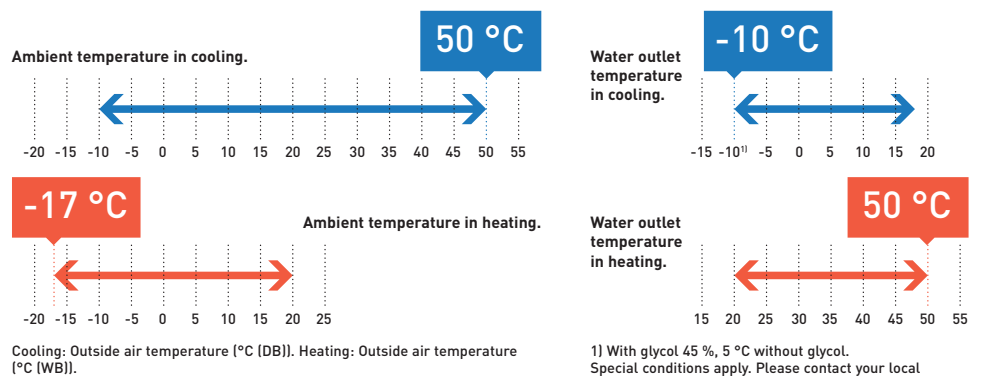

## ECOi-W the solution for hotels, offices and industry



Hotels.



Offices.



Industry.

Unrivaled Reliability and Quality.

Panasonic solutions can be enjoyed for years to come, even in the most extreme climates. Panasonic does not compromise on product quality, safety or durability, in order to provide the ultimate comfort when you need it most.

ECOi-W line-up

ECOi-W size	20	25	30	35	40	45	55	65	75	90	105	125	140	150	170	190	210	
Heat pump range																		
SEER	3,91	3,87	3,88	3,68	3,91	3,70	3,86	4,04	3,99	3,89	3,88	3,89	3,87	3,87	3,91	3,69	3,68	
SCOP	3,37	3,27	3,27	3,36	3,40	3,23	3,27	3,43	3,40	3,26	3,31	3,35	3,32	3,36	3,31	3,29	3,23	
Energy efficiency class (heating) <sup>1)</sup>	A+	A+	A+	A+	A+	A+	A+	A+										
ECOi-W size	20	25	30	35	40	45	55	65	75	90	105	125	140	150	170	190	210	
Cooling only range																		
SEER	4,59	4,45	4,23	4,42	4,21	4,12	4,12	4,41	4,32	4,23	4,12	4,24	4,35	4,31	4,40	4,23	4,22	
Energy efficiency class (SEER) <sup>2)</sup>	A+	A	A	A	A	A	A	A	A	A	A	A	A	A	A	A	A	
Dimensions (H x W x D) <sup>3)</sup>																		
	1983x1000x1000	1983x1000x1000	1983x1000x1000	1986x2180x1160	1986x2180x1160	1986x2180x1160	1986x2180x1160	2286x2180x1160	2286x2180x1160	2286x2180x1160	2295x2856x2210	2295x2856x2210	2295x2856x2210	2295x2856x2210	2321x2856x2210	2321x2856x2210	2321x2856x2210	

1) According to Eurovent and COMMISSION REGULATION (EU) No 813/2013 for low-temperature heat pumps. 2) According to Eurovent and COMMISSION REGULATION (EU) No 2016/2281 for comfort application chillers <400 kW. 3) Without buffer tanks.

Simple user friendly control

Main features	
Basic operation	ON/OFF setting
	Cooling / Heating mode setting
	Intelligent logic control for inlet water temperature
Energy Saving	Night setback operation to reduce electrical consumption and noise
	Part load operating mode
	Maximum discharge temperature control
	Automatic test operation at the push of a button
Service / Maintenance	Alarm notice with the latest 10 alarms
	Counter for operating hours of compressor and pump
	Compressor operating limits saved in a flash memory
Others	BMS compatible (RS485 ModBus RTU or BacNet MSTP protocol)



A control panel with intuitive design is equipped on all ECOi-W systems as standard. The microprocessor based control has a new IHM logic and implements a smart handling for your demand.

# Range of ECOi-W outdoor units

Page	Outdoor units	20 kW	25 kW	30 kW	35 kW	40 kW	45 kW	55 kW	65 kW	75 kW
------	---------------	-------	-------	-------	-------	-------	-------	-------	-------	-------

ECOi-W 20 to 40



<b>P. 224</b>	Heat pump	U-020CWNB	U-025CWNB	U-030CWNB	U-035CWNB	U-040CWNB
		U-020CWBS	U-025CWBS	U-030CWBS	U-035CWBS	U-040CWBS

<b>P. 230</b>	Cooling only	U-020CVNB	U-025CVNB	U-030CVNB	U-035CVNB	U-040CVNB
		U-020CVBS	U-025CVBS	U-030CVBS	U-035CVBS	U-040CVBS

ECOi-W 45 to 75



<b>P. 225</b>	Heat pump	U-045CWNB	U-055CWNB	U-065CWNB	U-075CWNB
		U-045CWBM	U-055CWBM	U-065CWBM	U-075CWBM

<b>P. 231</b>	Cooling only	U-045CVNB	U-055CVNB	U-065CVNB	U-075CVNB
		U-045CVBM	U-055CVBM	U-065CVBM	U-075CVBM

ECOi-W 90 to 125

**P. 226** Heat pump

**P. 232** Cooling only

ECOi-W 140 to 210

**P. 227** Heat pump

**P. 233** Cooling only

90 kW

105 kW

125 kW

140 kW

150 kW

170 kW

190 kW

210 kW



U-090CWNB  
U-090CWBM

U-105CWNB  
U-105CWBM

U-125CWNB  
U-125CWBM

U-090CVNB  
U-090CVBM

U-105CVNB  
U-105CVBM

U-125CVNB  
U-125CVBM



U-140CWNB  
U-140CWBL

U-150CWNB  
U-150CWBL

U-170CWNB  
U-170CWBL

U-190CWNB  
U-190CWBL

U-210CWNB  
U-210CWBL

U-140CVNB  
U-140CVBL

U-150CVNB  
U-150CVBL

U-170CVNB  
U-170CVBL

U-190CVNB  
U-190CVBL

U-210CVNB  
U-210CVBL



**PAW-SYSREMKIT**  
Optional Remote control.



**PAW-SYSSOV1**  
Optional Shut off valves kit for model 20 - 40.

**U - 020/025/030/035/040 CW**

Model		20	25	30	35	40
<b>Standard without buffer tank</b>		<b>U-020CWNB</b>	<b>U-025CWNB</b>	<b>U-030CWNB</b>	<b>U-035CWNB</b>	<b>U-040CWNB</b>
<b>With buffer tank</b>		<b>U-020CWBS</b>	<b>U-025CWBS</b>	<b>U-030CWBS</b>	<b>U-035CWBS</b>	<b>U-040CWBS</b>
Power supply	Voltage	V	400	400	400	400
	Phase		Three Phase	Three Phase	Three Phase	Three Phase
	Frequency	Hz	50	50	50	50
Cooling capacity <sup>1)</sup>	kW	19,4	25,3	26,9	35,8	37,4
Input power cooling <sup>1)</sup>	kW	6,10	8,61	9,34	13,51	13,64
Total EER 100 % <sup>1)</sup>		3,18	2,94	2,88	2,65	2,74
<b>SEER <sup>2)</sup></b>		<b>3,91</b>	<b>3,87</b>	<b>3,88</b>	<b>3,68</b>	<b>3,91</b>
$\eta_{sc}$ <sup>2)</sup>	%	153	152	152	144	153
Heating capacity <sup>3)</sup>	kW	19,5	26,9	29,7	37,3	41,6
Input power heating <sup>3)</sup>	kW	6,11	9,28	9,93	13,23	13,51
<b>SCOP <sup>4)</sup></b>		<b>3,37</b>	<b>3,27</b>	<b>3,27</b>	<b>3,36</b>	<b>3,40</b>
$\eta_{sh}$ <sup>4)</sup>	%	132	128	128	132	133
Energy efficiency class (Scale A+++ to D) <sup>5)</sup>		A+	A+	A+	A+	A+
Startup type		Direct	Direct	Direct	Direct	Direct
Maximum operating current	A	17,71	22,21	24,29	31,84	33,84
Startup current w/o softstarter / w softstarter	A	52,71/28,11	63,71/35,21	77,29/48,79	118,34/52,99	119,34/53,99
Sound power level (w standard fans)	dB(A)	75,0	75,0	75,0	76,0	76,0
Sound pressure level (w standard fans) <sup>6)</sup>	dB(A)	42,8	42,8	42,8	43,8	43,8
Dimensions (w standard fans) w/o buffer tank	H x W x D	mm	1983x1000x1000	1983x1000x1000	1983x1000x1000	1983x1000x1000
Dimensions (w standard fans) w buffer tank	H x W x D	mm	1983x1000x1507	1983x1000x1507	1983x1000x1507	1983x1000x1507
Weight (w 1 pump) w/o buffer tank	kg	280	290	320	330	330
Weight (w 1 pump) w buffer tank	kg	345	355	385	395	395
Refrigerant (R410A)	kg	6,5	8,4	8,4	9,1	9,2
Number of refrigerant circuit		1	1	1	1	1
<b>Compressors</b>						
Number		2	2	2	2	2
Type		Scroll	Scroll	Scroll	Scroll	Scroll
Part load step	%	0/50/100	0/50/100	0/50/100	0/50/100	0/50/100
Crankcase heater	W	2x40	2x40	2x49	2x49	2x49
<b>Evaporator</b>						
Number		1	1	1	1	1
Type		Plate	Plate	Plate	Plate	Plate
Nominal water flow (cooling)	m <sup>3</sup> /h	3,35	4,36	4,64	6,16	6,44
Water pressure drop (cooling)	kPa	23	37	22	37	40
Water volume	l	1,78	1,78	2,55	2,55	2,55
Antifreeze heater	W	30	30	30	30	30
<b>Coils</b>						
Number		1	1	1	1	1
Frontal surface	m <sup>2</sup>	2,4	2,4	2,4	2,8	2,8
Number of rows		2	2	2	2	2
<b>Fans standard</b>						
Number		1	1	1	1	1
Airflow	m <sup>3</sup> /h	9000	13000	13000	16000	16000
Rotation speed	r.p.m.	900	900	900	650	650
Power input (each fan)	W	620	940	940	930	930
<b>Water connections</b>						
Type		Male gas threaded BSPP ISO 228	Male gas threaded BSPP ISO 228	Male gas threaded BSPP ISO 228	Male gas threaded BSPP ISO 228	Male gas threaded BSPP ISO 228
Inlet - diameter	Inch	1 1/2	1 1/2	1 1/2	1 1/2	1 1/2
Outlet - diameter	Inch	1 1/2	1 1/2	1 1/2	1 1/2	1 1/2

**Accessories**

**PAW-SYSREMKIT** Remote control

**Accessories**

**PAW-SYSSOV1** Shut off valves kit for model 20 - 40

1) Data refers to 7 °C leaving chilled water temperature and 35 °C condenser air temperature, according EN14511 standard. 2) Following COMMISSION REGULATION (EU) No 2016/2281 for comfort application chillers. 3) Data refers to 45 °C leaving warm water temperature and 7 °C ambient coil air temperature with 87 % R.H., according EN14511 standard. 4) Following COMMISSION REGULATION (EU) No 813/2013 for low-temperature heat pumps. 5) Following COMMISSION REGULATION (EU) No 811/2013 for low-temperature heat pumps. Scale from A+++ to D, as of 26th September 2019. 6) Sound pressure levels calculated at 10 meters. Sound pressure levels refer to ISO standard 3744 with parallel piped shape.  
\* w: with, w/o: without.





**PAW-SYSREMKIT**  
Optional Remote control.**PAW-SYSSOV2**  
Optional Shut off valves kit for model 45 - 75.**U - 045/055/065/075 CW**

Model			45	55	65	75
<b>Standard without buffer tank</b>			<b>U-045CWNB</b>	<b>U-055CWNB</b>	<b>U-065CWNB</b>	<b>U-075CWNB</b>
<b>With buffer tank</b>			<b>U-045CWBM</b>	<b>U-055CWBM</b>	<b>U-065CWBM</b>	<b>U-075CWBM</b>
Power supply	Voltage	V	400	400	400	400
	Phase		Three Phase	Three Phase	Three Phase	Three Phase
	Frequency	Hz	50	50	50	50
Cooling capacity <sup>1)</sup>		kW	46,8	53,3	65,8	71,6
Input power cooling <sup>1)</sup>		kW	16,90	19,67	22,10	24,26
Total EER 100 % <sup>1)</sup>			2,77	2,71	2,98	2,95
<b>SEER <sup>2)</sup></b>			<b>3,70</b>	<b>3,86</b>	<b>4,04</b>	<b>3,99</b>
$\eta_{sc}$ <sup>2)</sup>		%	145	151	159	157
Heating capacity <sup>3)</sup>		kW	48,5	58,2	67,2	75,9
Input power heating <sup>3)</sup>		kW	17,32	20,35	22,47	24,33
<b>SCOP <sup>4)</sup></b>			<b>3,23</b>	<b>3,27</b>	<b>3,43</b>	<b>3,40</b>
$\eta_{sh}$ <sup>4)</sup>		%	126	128	134	133
Energy efficiency class (Scale A+++ to D) <sup>5)</sup>			A+	A+	A+	—
Startup type			Direct	Direct	Direct	Direct
Maximum operating current		A	40,20	44,20	59,43	64,43
Startup current w/o softstarter / w softstarter		A	133,20/65,80	140,20/72,80	201,43/101,03	206,43/106,03
Sound power level (w standard fans)		dB(A)	80,0	80,0	80,0	80,0
Sound pressure level (w standard fans) <sup>6)</sup>		dB(A)	47,8	47,8	47,8	47,8
Dimensions (w standard fans) w/o buffer tank	H x W x D	mm	1986 x 2180 x 1160	1986 x 2180 x 1160	1986 x 2180 x 1160	1986 x 2180 x 1160
Dimensions (w standard fans) w buffer tank	H x W x D	mm	1986 x 2680 x 1160	1986 x 2680 x 1160	1986 x 2680 x 1160	1986 x 2680 x 1160
Weight (w 1 pump) w/o buffer tank		kg	540	540	610	610
Weight (w 1 pump) w buffer tank		kg	700	700	770	770
Refrigerant (R410A)		kg	14,0	14,3	18,9	19,3
Number of refrigerant circuit			1	1	1	1
<b>Compressors</b>						
Number			2	2	2	2
Type			Scroll	Scroll	Scroll	Scroll
Part load step		%	0/50/100	0/43/57/100	0/40/60/100	0/45/55/100
Crankcase heater		W	2 x 66	2 x 66	2 x 66	2 x 66
<b>Evaporator</b>						
Number			1	1	1	1
Type			Plate	Plate	Plate	Plate
Nominal water flow (cooling)		m <sup>3</sup> /h	8,06	9,18	11,30	12,31
Water pressure drop (cooling)		kPa	30	35	28	37
Water volume		l	4,10	4,10	6,10	6,10
Antifreeze heater		W	30	30	2 x 30	2 x 30
<b>Coils</b>						
Number			1	1	2	2
Frontal surface		m <sup>2</sup>	4,20	4,20	5,55	5,55
Number of rows			2	2	2	2
<b>Fans standard</b>						
Number			1	1	2	2
Airflow		m <sup>3</sup> /h	22500	22500	15000	15000
Rotation speed		r.p.m.	790	790	650	650
Power input (each fan)		W	1650	1650	930	930
<b>Water connections</b>						
Type			Male gas threaded BSPP ISO 228	Male gas threaded BSPP ISO 228	Male gas threaded BSPP ISO 228	Male gas threaded BSPP ISO 228
Inlet - diameter		Inch	2	2	2	2
Outlet - diameter		Inch	2	2	2	2

**Accessories****PAW-SYSREMKIT** Remote control**Accessories****PAW-SYSSOV2** Shut off valves kit for model 45 - 75

1) Data refers to 7 °C leaving chilled water temperature and 35 °C condenser air temperature, according EN14511 standard. 2) Following COMMISSION REGULATION (EU) No 2016/2281 for comfort application chillers. 3) Data refers to 45 °C leaving warm water temperature and 7 °C ambient coil air temperature with 87 % R.H., according EN14511 standard. 4) Following COMMISSION REGULATION (EU) No 813/2013 for low-temperature heat pumps. 5) Following COMMISSION REGULATION (EU) No 811/2013 for low-temperature heat pumps. Scale from A+++ to D, as of 26th September 2019. 6) Sound pressure levels calculated at 10 meters. Sound pressure levels refer to ISO standard 3744 with parallel piped shape.

\* w: with, w/o: without.





**PAW-SYSREMKIT**  
Optional Remote control.



**PAW-SYSSOV3**  
Optional Shut off valves kit for model 90 - 125.

## U - 090/105/125 CW

Model		90	105	125
<b>Standard without buffer tank</b>		<b>U-090CWNB</b>	<b>U-105CWNB</b>	<b>U-125CWNB</b>
<b>With buffer tank</b>		<b>U-090CWBM</b>	<b>U-105CWBM</b>	<b>U-125CWBM</b>
Power supply	Voltage	V	400	400
	Phase		Three Phase	Three Phase
	Frequency	Hz	50	50
Cooling capacity <sup>1)</sup>	kW	91,4	106,2	121,9
Input power cooling <sup>1)</sup>	kW	34,36	38,06	46,35
Total EER 100 % <sup>1)</sup>		2,66	2,79	2,63
<b>SEER <sup>2)</sup></b>		<b>3,89</b>	<b>3,88</b>	<b>3,89</b>
$\eta_{sc}$ <sup>2)</sup>	%	153	152	153
Heating capacity <sup>3)</sup>	kW	88,1	101,0	119,1
Input power heating <sup>3)</sup>	kW	33,75	38,40	45,46
<b>SCOP <sup>4)</sup></b>		<b>3,26</b>	<b>3,31</b>	<b>3,35</b>
$\eta_{sh}$ <sup>4)</sup>	%	128	129	131
Startup type		Direct	Direct	Direct
Maximum operating current	A	77,90	85,96	101,96
Startup current w/o softstarter / w softstarter	A	264,90 / 127,30	311,96 / 145,76	349,96 / 182,56
Sound power level (w standard fans)	dB(A)	83,0	83,0	83,0
Sound pressure level (w standard fans) <sup>5)</sup>	dB(A)	50,8	50,8	50,8
Dimensions (w standard fans) w/o buffer tank	H x W x D	mm	2286 x 2180 x 1160	2286 x 2180 x 1160
Dimensions (w standard fans) w buffer tank	H x W x D	mm	2286 x 2680 x 1160	2286 x 2680 x 1160
Weight (w 1 pump) w/o buffer tank	kg	790	900	920
Weight (w 1 pump) w buffer tank	kg	950	1060	1080
Refrigerant (R410A)	kg	22,0	32,3	33,0
Number of refrigerant circuit		1	1	1
<b>Compressors</b>				
Number		2	2	2
Type		Scroll	Scroll	Scroll
Part load step	%	0/45/55/100	0/38/62/100	0/33/67/100
Crankcase heater	W	66/82	66/95	66/95
<b>Evaporator</b>				
Number		1	1	1
Type		Plate	Plate	Plate
Nominal water flow (cooling)	m <sup>3</sup> /h	15,73	18,25	20,95
Water pressure drop (cooling)	kPa	26	34	45
Water volume	l	10,80	10,80	10,80
Antifreeze heater	W	2 x 30	2 x 30	2 x 30
<b>Coils</b>				
Number		2	2	2
Frontal surface	m <sup>2</sup>	6,4	6,4	6,4
Number of rows		2	3	3
<b>Fans standard</b>				
Number		2	2	2
Airflow	m <sup>3</sup> /h	21000	21000	21000
Rotation speed	r.p.m.	790	790	790
Power input (each fan)	W	1650	1650	1650
<b>Water connections</b>				
Type		Male gas threaded BSPP ISO 228	Male gas threaded BSPP ISO 228	Male gas threaded BSPP ISO 228
Inlet - diameter	Inch	2 1/2	2 1/2	2 1/2
Outlet - diameter	Inch	2 1/2	2 1/2	2 1/2

### Accessories

**PAW-SYSREMKIT** Remote control

### Accessories

**PAW-SYSSOV3** Shut off valves kit for model 90 - 125

1) Data refers to 7 °C leaving chilled water temperature and 35 °C condenser air temperature, according EN14511 standard. 2) Following COMMISSION REGULATION (EU) No 2016/2281 for comfort application chillers. 3) Data refers to 45 °C leaving warm water temperature and 7 °C ambient coil air temperature with 87 % R.H., according EN14511 standard. 4) Following COMMISSION REGULATION (EU) No 813/2013 for low-temperature heat pumps. 5) Sound pressure levels calculated at 10 meters. Sound pressure levels refer to ISO standard 3744 with parallel piped shape.

\* w: with, w/o: without.



PAW-SYSREMKIT  
Optional Remote control.**U - 140/150/170/190/210 CW**

Model		140	150	170	190	210	
<b>Standard without buffer tank</b>		<b>U-140CWNB</b>	<b>U-150CWNB</b>	<b>U-170CWNB</b>	<b>U-190CWNB</b>	<b>U-210CWNB</b>	
<b>With buffer tank</b>		<b>U-140CWBL</b>	<b>U-150CWBL</b>	<b>U-170CWBL</b>	<b>U-190CWBL</b>	<b>U-210CWBL</b>	
Power supply	Voltage	V	400	400	400	400	
	Phase		Three Phase	Three Phase	Three Phase	Three Phase	
Cooling capacity <sup>1)</sup>	Frequency	Hz	50	50	50	50	
		kW	125,4	137,6	150,9	175,8	195,4
Input power cooling <sup>1)</sup>		kW	43,55	47,77	52,73	64,83	72,54
Total EER 100 % <sup>1)</sup>			2,88	2,88	2,86	2,71	2,69
<b>SEER <sup>2)</sup></b>			<b>3,87</b>	<b>3,87</b>	<b>3,91</b>	<b>3,69</b>	<b>3,68</b>
$\eta_{sc}$ <sup>2)</sup>		%	152	152	153	145	144
Heating capacity <sup>3)</sup>		kW	143,7	153,7	170,1	194,9	217,6
Input power heating <sup>3)</sup>		kW	45,80	50,20	55,40	67,50	78,30
<b>SCOP <sup>4)</sup></b>			<b>3,32</b>	<b>3,36</b>	<b>3,31</b>	<b>3,29</b>	<b>3,23</b>
$\eta_{sh}$ <sup>4)</sup>		%	130	132	129	129	126
Startup type			Direct	Direct	Direct	Direct	Direct
Maximum operating current		A	108,00	119,00	136,00	153,00	170,00
Startup current w/o softstarter / w softstarter		A	251,00/130,00	262,00/141,00	324,00/161,00	341,00/178,00	396,00/201,00
Sound power level (w standard fans)		dB(A)	85,4	85,4	87,0	88,1	88,1
Sound pressure level (w standard fans) <sup>5)</sup>		dB(A)	53,4	53,4	55,0	56,1	56,1
Dimensions (w standard fans) w/o buffer tank	H x W x D	mm	2295 x 2856 x 2210	2295 x 2856 x 2210	2295 x 2856 x 2210	2295 x 2856 x 2210	2295 x 2856 x 2210
Dimensions (w standard fans) w buffer tank	H x W x D	mm	2295 x 3666 x 2210	2295 x 3666 x 2210	2295 x 3666 x 2210	2295 x 3666 x 2210	2295 x 3666 x 2210
Weight (w 1 low Pa pump) w/o buffer tank		kg	1512	1515	1605	1677	1937
Weight (w 1 low Pa pump) w buffer tank		kg	1644	1647	1737	1809	2069
Refrigerant (R410A)		kg	2 x 24,7	2 x 24,7	24,7/33,3	2 x 33,3	2 x 33,3
Number of refrigerant circuit			2	2	2	2	2
<b>Compressors</b>							
Number			4	4	4	4	4
Type			Scroll	Scroll	Scroll	Scroll	Scroll
Part load step	%		0 / 24 / 26 / 48 / 50 / 52 / 74 / 76 / 100	0 / 23 / 27 / 46 / 50 / 54 / 73 / 77 / 100	0 / 20 / 24 / 44 / 45 / 55 / 69 / 80 / 100	0 / 22 / 28 / 44 / 50 / 56 / 72 / 78 / 100	0 / 19 / 31 / 38 / 50 / 62 / 69 / 81 / 100
Crankcase heater	W		4 x 66	4 x 66	3 x 66/82	2 x 82/2 x 66	2 x 95/2 x 66
<b>Evaporator</b>							
Number			1	1	1	1	1
Type			Plate	Plate	Plate	Plate	Plate
Nominal water flow (cooling)	m <sup>3</sup> /h		21,56	23,65	25,95	30,24	33,62
Water pressure drop (cooling)	kPa		33	39	24	32	40
Water volume	l		8,49	8,49	12,21	12,21	12,21
Antifreeze heater	W		60	60	120	120	120
<b>Coils</b>							
Number			4	4	4	4	4
Frontal surface	m <sup>2</sup>		11,88	11,88	11,88	11,88	11,88
Number of rows			2+2	2+2	2+3	3+3	3+3
<b>Fans standard</b>							
Number			4	4	4	4	4
Airflow	m <sup>3</sup> /h		56000	56000	71000	86000	83000
Rotation speed	r.p.m.		900	900	900	900	900
Power input (each fan)	W		940	940	940 - 1650	1650	1650
<b>Water connections</b>							
Type			Victaulic	Victaulic	Victaulic	Victaulic	Victaulic
Inlet - diameter	Inch		2 1/2	2 1/2	2 1/2	2 1/2	2 1/2
Outlet - diameter	Inch		2 1/2	2 1/2	2 1/2	2 1/2	2 1/2

**Accessories**

PAW-SYSREMKIT Remote control

**Accessories**

PAW-SYSVICTH Victaulic connection kit for model 140 - 210

1) Data refers to 7 °C leaving chilled water temperature and 35 °C condenser air temperature, according EN14511 standard. 2) Following COMMISSION REGULATION (EU) No 2016/2281 for comfort application chillers. 3) Data refers to 45 °C leaving warm water temperature and 7 °C ambient coil air temperature with 87 % R.H., according EN14511 standard. 4) Following COMMISSION REGULATION (EU) No 813/2013 for low-temperature heat pumps. 5) Sound pressure levels calculated at 10 meters. Sound pressure levels refer to ISO standard 3744 with parallel piped shape.  
\* w: with, w/o: without.







**Options table 140 - 210**

Option	Type	Ref.	Description	Model				
				140	150	170	190	210
1	Capacity							
2	Refrigerant & compressor type	W	R410A fixed speed	•	•	•	•	•
3	Buffer tank option	NB	No buffer	Std	Std	Std	Std	Std
		BL	Buffer tank (large)	•	•	•	•	•
4	Pump option		No pump	Std	Std	Std	Std	Std
			Single pump low pressure	•	•	•	•	•
			Single pump high pressure	•	•	•	•	•
			Double pump low pressure	•	•	•	•	•
5	Pump drive option		Double pump high pressure	•	•	•	•	•
			Pump drive - fixed speed <sup>1)</sup>	Std	Std	Std	Std	Std
			Pump drive - variable twin speed (single pump)	•	•	•	•	•
			Pump drive - variable twin speed (double pump)	•	•	•	•	•
			Pump drive - variable capacity (single pump)	•	•	•	•	•
			Pump drive - variable capacity (double pump)	•	•	•	•	•
			Pump drive - constant outlet pressure (single pump)	•	•	•	•	•
			Pump drive - constant outlet pressure (double pump)	•	•	•	•	•
6	Hydraulic options		Pump drive - constant differential pressure (single pump) <sup>2)</sup>	S0	S0	S0	S0	S0
			Pump drive - constant differential pressure (double pump) <sup>2)</sup>	S0	S0	S0	S0	S0
			No hydraulic option	Std	Std	Std	Std	Std
			Low water pressure sensor	•	•	•	•	•
7	Ambient options		Water isolation valves	•	•	•	•	•
			Hydraulic gauges	•	•	•	•	•
			No ambient options	Std	Std	Std	Std	Std
			Finned coil treatment - epoxy	•	•	•	•	•
			Outdoor coil protection grid <sup>3)</sup>	•	•	•	•	•
			Rubber pads	•	•	•	•	•
			Spring damper	•	•	•	•	•
			Fan speed control (FSC)	•	•	•	•	•
8	Miscellaneous options		Nordic pack	•	•	•	•	•
			Low noise	Std	Std	Std	Std	Std
			High pressure fan	•	•	•	•	•
			No miscellaneous options	Std	Std	Std	Std	Std
			Soft starter	•	•	•	•	•
			Power supply w/o neutral	•	•	•	•	•
			Standard BMS Option (Modbus RTU)	Std	Std	Std	Std	Std
			Modbus TCP/IP	•	•	•	•	•
	BACnet IP	•	•	•	•	•		
	Remote LAN connection	Std	Std	Std	Std	Std		
	Refrigerant gauge	•	•	•	•	•		

1) Fixed speed pump drive is standard when selecting a pump. Please select an alternative pump drive if required.

2) Constant differential pump drive options are only available on a special order and requires additional production time. Please contact your local sales representative.

3) Not available when using Nordic pack.



**PAW-SYSREMKIT**  
Optional Remote control.



**PAW-SYSSOV1**  
Optional Shut off valves kit for model 20 - 40.

## U - 020/025/030/035/040 CV

Model		20	25	30	35	40
<b>Standard without buffer tank</b>		<b>U-020CVNB</b>	<b>U-025CVNB</b>	<b>U-030CVNB</b>	<b>U-035CVNB</b>	<b>U-040CVNB</b>
<b>With buffer tank</b>		<b>U-020CVBS</b>	<b>U-025CVBS</b>	<b>U-030CVBS</b>	<b>U-035CVBS</b>	<b>U-040CVBS</b>
Power supply	Voltage	V	400	400	400	400
	Phase		Three Phase	Three Phase	Three Phase	Three Phase
	Frequency	Hz	50	50	50	50
Cooling capacity <sup>1)</sup>	kW	19,3	24,7	27,1	38,2	40,9
Input power cooling <sup>1)</sup>	kW	6,10	7,69	9,00	12,20	13,40
Total EER 100 % <sup>1)</sup>		3,16	3,21	3,01	3,13	3,05
<b>SEER <sup>2)</sup></b>		<b>4,59</b>	<b>4,45</b>	<b>4,23</b>	<b>4,42</b>	<b>4,21</b>
$\eta_{sc}$ <sup>2)</sup>	%	181	175	166	174	166
Energy efficiency class (Scale A+++ to D) <sup>3)</sup>		A+	A	A	A	A
Startup type		Direct	Direct	Direct	Direct	Direct
Maximum operating current	A	17,71	22,21	24,29	31,84	33,84
Startup current w/o softstarter / w softstarter	A	52,71/28,11	63,71/35,21	77,29/48,79	118,34/52,99	119,34/53,99
Sound power level (w standard fans)	dB(A)	75,0	75,0	75,0	76,0	76,0
Sound pressure level (w standard fans) <sup>4)</sup>	dB(A)	42,8	42,8	42,8	43,8	43,8
Dimensions (w standard fans) w/o buffer tank	H x W x D	mm	1983x1000x1000	1983x1000x1000	1983x1000x1000	1983x1000x1000
Dimensions (w standard fans) w buffer tank	H x W x D	mm	1983x1000x1507	1983x1000x1507	1983x1000x1507	1983x1000x1507
Weight (w 1 pump) w/o buffer tank	kg	280	290	320	330	330
Weight (w 1 pump) w buffer tank	kg	345	355	385	395	395
Refrigerant (R410A)	kg	6,5	8,4	8,4	9,1	9,2
Number of refrigerant circuit		1	1	1	1	1
<b>Compressors</b>						
Number		2	2	2	2	2
Type		Scroll	Scroll	Scroll	Scroll	Scroll
Part load step	%	0/50/100	0/50/100	0/50/100	0/50/100	0/50/100
Crankcase heater	W	2x40	2x40	2x49	2x49	2x49
<b>Evaporator</b>						
Number		1	1	1	1	1
Type		Plate	Plate	Plate	Plate	Plate
Nominal water flow (cooling)	m <sup>3</sup> /h	3,35	4,36	4,64	6,16	6,44
Water pressure drop (cooling)	kPa	23	37	22	37	40
Water volume	l	1,78	1,78	2,55	2,55	2,55
Antifreeze heater	W	30	30	30	30	30
<b>Coils</b>						
Number		1	1	1	1	1
Frontal surface	m <sup>2</sup>	2,4	2,4	2,4	2,8	2,8
Number of rows		2	2	2	2	2
<b>Fans standard</b>						
Number		1	1	1	1	1
Airflow	m <sup>3</sup> /h	9000	13000	13000	16000	16000
Rotation speed	r.p.m.	900	900	900	650	650
Power input (each fan)	W	620	940	940	930	930
<b>Water connections</b>						
Type		Male gas threaded BSPP ISO 228	Male gas threaded BSPP ISO 228	Male gas threaded BSPP ISO 228	Male gas threaded BSPP ISO 228	Male gas threaded BSPP ISO 228
Inlet - diameter	Inch	1 1/2	1 1/2	1 1/2	1 1/2	1 1/2
Outlet - diameter	Inch	1 1/2	1 1/2	1 1/2	1 1/2	1 1/2

### Accessories

**PAW-SYSREMKIT** Remote control

### Accessories

**PAW-SYSSOV1** Shut off valves kit for model 20 - 40

1) Data refers to 7 °C leaving chilled water temperature and 35 °C condenser air temperature, according EN14511 standard. 2) Following COMMISSION REGULATION (EU) No 2016/2281 for comfort application chillers. 3) Following COMMISSION REGULATION (EU) No 811/2013 for low-temperature heat pumps. Scale from A+++ to D, as of 26th September 2019. 4) Sound pressure levels calculated at 10 meters. Sound pressure levels refer to ISO standard 3744 with parallel piped shape.

\* w: with, w/o: without.



PAW-SYSREMKIT  
Optional Remote  
control.PAW-SYSSOV2  
Optional Shut off  
valves kit for model  
45 - 75.**U - 045/055/065/075 CV**

Model			45	55	65	75		
<b>Standard without buffer tank</b>			<b>U-045CVNB</b>	<b>U-055CVNB</b>	<b>U-065CVNB</b>	<b>U-075CVNB</b>		
<b>With buffer tank</b>			<b>U-045CVBM</b>	<b>U-055CVBM</b>	<b>U-065CVBM</b>	<b>U-075CVBM</b>		
Power supply	Voltage	V	400	400	400	400		
	Phase		Three Phase	Three Phase	Three Phase	Three Phase		
	Frequency	Hz	50	50	50	50		
Cooling capacity <sup>1)</sup>		kW	49,8	56,9	69,7	75,8		
Input power cooling <sup>1)</sup>		kW	16,70	18,80	22,10	22,10		
Total EER 100 % <sup>1)</sup>			2,98	3,03	3,15	3,13		
<b>SEER <sup>2)</sup></b>			<b>4,12</b>	<b>4,12</b>	<b>4,41</b>	<b>4,32</b>		
$\eta_{sc}$ <sup>2)</sup>		%	162	162	174	170		
Energy efficiency class (Scale A+++ to D) <sup>3)</sup>			A	A	A	A		
Startup type			Direct	Direct	Direct	Direct		
Maximum operating current			A	40,20	44,20	59,43	64,43	
Startup current w/o softstarter / w softstarter			A	133,20/65,80	140,20/72,80	201,43/101,03	206,43/106,03	
Sound power level (w standard fans)				80,0	80,0	80,0	80,0	
Sound pressure level (w standard fans) <sup>4)</sup>				47,8	47,8	47,8	47,8	
Dimensions (w standard fans) w/o buffer tank			H x W x D	mm	1986 x 2180 x 1160	1986 x 2180 x 1160	1986 x 2180 x 1160	
Dimensions (w standard fans) w buffer tank			H x W x D	mm	1986 x 2680 x 1160	1986 x 2680 x 1160	1986 x 2680 x 1160	
Weight (w 1 pump) w/o buffer tank				kg	540	540	610	610
Weight (w 1 pump) w buffer tank				kg	700	700	770	770
Refrigerant (R410A)				kg	14,0	14,3	18,9	19,3
Number of refrigerant circuit					1	1	1	1
<b>Compressors</b>								
Number				2	2	2	2	
Type				Scroll	Scroll	Scroll	Scroll	
Part load step			%	0/50/100	0/43/57/100	0/40/60/100	0/45/55/100	
Crankcase heater			W	2 x 66	2 x 66	2 x 66	2 x 66	
<b>Evaporator</b>								
Number				1	1	1	1	
Type				Plate	Plate	Plate	Plate	
Nominal water flow (cooling)			m <sup>3</sup> /h	8,06	9,18	11,30	12,31	
Water pressure drop (cooling)			kPa	30	35	28	37	
Water volume			l	4,10	4,10	6,10	6,10	
Antifreeze heater			W	30	30	2 x 30	2 x 30	
<b>Coils</b>								
Number				1	1	2	2	
Frontal surface			m <sup>2</sup>	4,20	4,20	5,55	5,55	
Number of rows				2	2	2	2	
<b>Fans standard</b>								
Number				1	1	2	2	
Airflow			m <sup>3</sup> /h	22500	22500	15000	15000	
Rotation speed			r.p.m.	790	790	650	650	
Power input (each fan)			W	1650	1650	930	930	
<b>Water connections</b>								
Type				Male gas threaded BSPP ISO 228	Male gas threaded BSPP ISO 228	Male gas threaded BSPP ISO 228	Male gas threaded BSPP ISO 228	
Inlet - diameter			Inch	2	2	2	2	
Outlet - diameter			Inch	2	2	2	2	

**Accessories**

PAW-SYSREMKIT Remote control

**Accessories**

PAW-SYSSOV2 Shut off valves kit for model 45 - 75

1) Data refers to 7 °C leaving chilled water temperature and 35 °C condenser air temperature, according EN14511 standard. 2) Following COMMISSION REGULATION (EU) No 2016/2281 for comfort application chillers. 3) Following COMMISSION REGULATION (EU) No 811/2013 for low-temperature heat pumps. Scale from A+++ to D, as of 26th September 2019. 4) Sound pressure levels calculated at 10 meters. Sound pressure levels refer to ISO standard 3744 with parallel piped shape.

\* w: with, w/o: without.





**PAW-SYSREMKIT**  
Optional Remote control.



**PAW-SYSSOV3**  
Optional Shut off valves kit for model 90 - 125.

## U - 090/105/125 CV

Model	90		105		125	
<b>Standard without buffer tank</b>	<b>U-090CVNB</b>		<b>U-105CVNB</b>		<b>U-125CVNB</b>	
<b>With buffer tank</b>	<b>U-090CVBM</b>		<b>U-105CVBM</b>		<b>U-125CVBM</b>	
Power supply	Voltage	V	400		400	
	Phase		Three Phase		Three Phase	
	Frequency	Hz	50		50	
Cooling capacity <sup>1)</sup>		kW	97,0	112,7	129,8	
Input power cooling <sup>1)</sup>		kW	24,20	32,50	38,60	
Total EER 100 % <sup>1)</sup>			2,98	2,92	2,93	
<b>SEER <sup>2)</sup></b>			<b>4,23</b>	<b>4,12</b>	<b>4,24</b>	
$\eta_{sc}$ <sup>2)</sup>		%	166	162	167	
Energy efficiency class [Scale A+++ to D] <sup>3)</sup>			A	A	A	
Startup type			Direct	Direct	Direct	
Maximum operating current		A	77,90	86,00	102,00	
Startup current w/o softstarter / w softstarter		A	264,90/127,30	311,96/145,76	349,96/182,56	
Sound power level (w standard fans)		dB(A)	83,0	83,0	83,0	
Sound pressure level (w standard fans) <sup>4)</sup>		dB(A)	50,8	50,8	50,8	
Dimensions (w standard fans) w/o buffer tank	H x W x D	mm	2286 x 2180 x 1160	2286 x 2180 x 1160	2286 x 2180 x 1160	
Dimensions (w standard fans) w buffer tank	H x W x D	mm	2286 x 2680 x 1160	2286 x 2680 x 1160	2286 x 2680 x 1160	
Weight (w 1 pump) w/o buffer tank		kg	790	900	920	
Weight (w 1 pump) w buffer tank		kg	950	1060	1080	
Refrigerant [R410A]		kg	22,0	32,3	33,0	
Number of refrigerant circuit			1	1	1	
<b>Compressors</b>						
Number			2	2	2	
Type			Scroll	Scroll	Scroll	
Part load step		%	0/45/55/100	0/38/62/100	0/33/67/100	
Crankcase heater		W	66/82	66/95	66/95	
<b>Evaporator</b>						
Number			1	1	1	
Type			Plate	Plate	Plate	
Nominal water flow (cooling)		m <sup>3</sup> /h	15,73	18,25	20,95	
Water pressure drop (cooling)		kPa	26	34	45	
Water volume		l	10,80	10,80	10,80	
Antifreeze heater		W	2x30	2x30	2x30	
<b>Coils</b>						
Number			2	2	2	
Frontal surface		m <sup>2</sup>	6,4	6,4	6,4	
Number of rows			2	3	3	
<b>Fans standard</b>						
Number			2	2	2	
Airflow		m <sup>3</sup> /h	21000	21000	21000	
Rotation speed		r.p.m.	790	790	790	
Power input (each fan)		W	1650	1650	1650	
<b>Water connections</b>						
Type			Male gas threaded BSPP ISO 228	Male gas threaded BSPP ISO 228	Male gas threaded BSPP ISO 228	
Inlet - diameter		Inch	2 1/2	2 1/2	2 1/2	
Outlet - diameter		Inch	2 1/2	2 1/2	2 1/2	

### Accessories

**PAW-SYSREMKIT** Remote control

### Accessories

**PAW-SYSSOV3** Shut off valves kit for model 90 - 125

1) Data refers to 7 °C leaving chilled water temperature and 35 °C condenser air temperature, according EN14511 standard. 2) Following COMMISSION REGULATION (EU) No 2016/2281 for comfort application chillers. 3) Following COMMISSION REGULATION (EU) No 811/2013 for low-temperature heat pumps. Scale from A+++ to D, as of 26th September 2019. 4) Sound pressure levels calculated at 10 meters. Sound pressure levels refer to ISO standard 3744 with parallel piped shape.

\* w: with, w/o: without.





PAW-SYSREMKIT  
Optional Remote control.**U - 140/150/170/190/210 CV**

Model			140	150	170	190	210
<b>Standard without buffer tank</b>			<b>U-140CVNB</b>	<b>U-150CVNB</b>	<b>U-170CVNB</b>	<b>U-190CVNB</b>	<b>U-210CVNB</b>
<b>With buffer tank</b>			<b>U-140CVBL</b>	<b>U-150CVBL</b>	<b>U-170CVBL</b>	<b>U-190CVBL</b>	<b>U-210CVBL</b>
Power supply	Voltage	V	400	400	400	400	400
	Phase		Three Phase	Three Phase	Three Phase	Three Phase	Three Phase
	Frequency	Hz	50	50	50	50	50
Cooling capacity <sup>1)</sup>		kW	134,0	147,0	161,2	187,8	208,8
Input power cooling <sup>1)</sup>		kW	44,15	49,00	53,70	64,50	72,30
Total EER 100 % <sup>1)</sup>			3,03	3,00	3,00	2,91	2,89
<b>SEER <sup>2)</sup></b>			<b>4,35</b>	<b>4,31</b>	<b>4,40</b>	<b>4,23</b>	<b>4,22</b>
$\eta_{sc}$ <sup>2)</sup>		%	171	169	173	166	166
Energy efficiency class (Scale A+++ to D) <sup>3)</sup>			A	A	A	A	A
Startup type			Direct	Direct	Direct	Direct	Direct
Maximum operating current		A	108,00	119,00	136,00	153,00	170,00
Startup current w/o softstarter / w softstarter		A	251,00/130,00	262,00/141,00	324,00/161,00	341,00/178,00	396,00/201,00
Sound power level (w standard fans)		dB(A)	85,4	85,4	87,0	88,1	88,1
Sound pressure level (w standard fans) <sup>4)</sup>		dB(A)	53,4	53,4	55,0	56,1	56,1
Dimensions (w standard fans) w/o buffer tank	H x W x D	mm	2295 x 2856 x 2210	2295 x 2856 x 2210	2295 x 2856 x 2210	2295 x 2856 x 2210	2295 x 2856 x 2210
Dimensions (w standard fans) w buffer tank	H x W x D	mm	2295 x 3666 x 2210	2295 x 3666 x 2210	2295 x 3666 x 2210	2295 x 3666 x 2210	2295 x 3666 x 2210
Weight (w 1 low Pa pump) w/o buffer tank		kg	1512	1515	1605	1677	1937
Weight (w 1 low Pa pump) w buffer tank		kg	1644	1647	1737	1809	2069
Refrigerant (R410A)		kg	2 x 24,7	2 x 24,7	24,7/33,3	2 x 33,3	2 x 33,3
Number of refrigerant circuit			2	2	2	2	2
<b>Compressors</b>							
Number			4	4	4	4	4
Type			Scroll	Scroll	Scroll	Scroll	Scroll
Part load step		%	0 / 24 / 26 / 48 / 50 / 52 / 74 / 76 / 100	0 / 23 / 27 / 46 / 50 / 54 / 73 / 77 / 100	0 / 20 / 24 / 44 / 45 / 55 / 69 / 80 / 100	0 / 22 / 28 / 44 / 50 / 56 / 72 / 78 / 100	0 / 19 / 31 / 38 / 50 / 62 / 69 / 81 / 100
Crankcase heater		W	4 x 66	4 x 66	3 x 66/82	2 x 82/2 x 66	2 x 95/2 x 66
<b>Evaporator</b>							
Number			1	1	1	1	1
Type			Plate	Plate	Plate	Plate	Plate
Nominal water flow (cooling)		m <sup>3</sup> /h	21,56	23,65	25,95	30,24	33,62
Water pressure drop (cooling)		kPa	33	39	24	32	40
Water volume		l	8,49	8,49	12,21	12,21	12,21
Antifreeze heater		W	60	60	120	120	120
<b>Coils</b>							
Number			4	4	4	4	4
Frontal surface		m <sup>2</sup>	11,88	11,88	11,88	11,88	11,88
Number of rows			2+2	2+2	2+3	3+3	3+3
<b>Fans standard</b>							
Number			4	4	4	4	4
Airflow		m <sup>3</sup> /h	56000	56000	71000	86000	83000
Rotation speed		r.p.m.	900	900	900	900	900
Power input (each fan)		W	940	940	940 - 1650	1650	1650
<b>Water connections</b>							
Type			Victaulic	Victaulic	Victaulic	Victaulic	Victaulic
Inlet - diameter		Inch	2 1/2	2 1/2	2 1/2	2 1/2	2 1/2
Outlet - diameter		Inch	2 1/2	2 1/2	2 1/2	2 1/2	2 1/2

**Accessories**

PAW-SYSREMKIT Remote control

**Accessories**

PAW-SYSVICTH Victaulic connection kit for model 140 - 210

1) Data refers to 7 °C leaving chilled water temperature and 35 °C condenser air temperature, according EN14511 standard. 2) Following COMMISSION REGULATION (EU) No 2016/2281 for comfort application chillers. 3) Following COMMISSION REGULATION (EU) No 811/2013 for low-temperature heat pumps. Scale from A+++ to D, as of 26th September 2019. 4) Sound pressure levels calculated at 10 meters. Sound pressure levels refer to ISO standard 3744 with parallel piped shape.

\* w: with, w/o: without.





# Options for cooling only outdoor units

Options table 20 - 125

Option	Type	Ref.	Model												
			20	25	30	35	40	45	55	65	75	90	105	125	
1	Capacity		20	25	30	35	40	45	55	65	75	90	105	125	
2	Refrigerant & compressor type	W	R410A fixed speed	•	•	•	•	•	•	•	•	•	•	•	
3	Buffer tank option	NB	No buffer	Std	Std	Std	Std	Std	Std	Std	Std	Std	Std	Std	
		BS	Buffer tank (small)	•	•	•	•	•							
		BM	Buffer tank (medium )						•	•	•	•	•	•	•
4	Pump option	No pump <sup>1)</sup>	•	•	•	•	•	Std	Std	Std	Std	Std	Std	Std	
		Single pump	Std	Std	Std	Std	Std	•	•	•	•	•	•	•	
		Double pump						•	•	•	•	•	•	•	
5	Pump drive option	Pump drive - fixed speed <sup>2)</sup>	•	•	•	•	•	•	•	•	•	•	•	•	
		Pump drive - variable twin speed (single pump)	Std	Std	Std	Std	Std	•	•	•	•	•	•	•	
		Pump drive - variable twin speed (double pump)						•	•	•	•	•	•	•	
		Pump drive - variable capacity (single pump)	•	•	•	•	•	•	•	•	•	•	•	•	•
		Pump drive - variable capacity (double pump)						•	•	•	•	•	•	•	
		Pump drive - constant outlet pressure (single pump)	•	•	•	•	•	•	•	•	•	•	•	•	•
		Pump drive - constant outlet pressure (double pump)						•	•	•	•	•	•	•	•
		Pump drive - constant differential pressure (single pump) <sup>3)</sup>	S0	S0	S0	S0	S0	S0	S0	S0	S0	S0	S0	S0	S0
6	Hydraulic options	No hydraulic option	Std	Std	Std	Std	Std	Std	Std	Std	Std	Std	Std	Std	
		Low water pressure sensor	•	•	•	•	•	•	•	•	•	•	•	•	
		Water isolation valves	•	•	•	•	•	•	•	•	•	•	•	•	
		No ambient options	Std	Std	Std	Std	Std	Std	Std	Std	Std	Std	Std	Std	
		Finned coil treatment - epoxy	•	•	•	•	•	•	•	•	•	•	•	•	•
7	Ambient options	Outdoor coil protection grid	•	•	•	•	•	•	•	•	•	•	•	•	
		Rubber pads	•	•	•	•	•	•	•	•	•	•	•	•	
		Spring damper	•	•	•	•	•	•	•	•	•	•	•	•	
		Fan speed control (FSC)	•	•	•	•	•	•	•	•	•	•	•	•	
		Low noise	Std	Std	Std	Std	Std	•	•	•	•	•	•	•	
		High pressure fan <sup>4)</sup>		•	•	•	•	•	•	•	•	•	•	•	
		No miscellaneous options	Std	Std	Std	Std	Std	Std	Std	Std	Std	Std	Std	Std	
		Soft starter	•	•	•	•	•	•	•	•	•	•	•	•	•
		Power supply w/o neutral <sup>5)</sup>	S0	S0	S0	S0	S0	S0	S0	S0	S0	S0	S0	S0	
		Standard BMS option (Modbus RTU)	Std	Std	Std	Std	Std	Std	Std	Std	Std	Std	Std	Std	
8	Miscellaneous options	Modbus TCP/IP	•	•	•	•	•	•	•	•	•	•	•	•	
		BACnet MSTP	•	•	•	•	•	•	•	•	•	•	•	•	
		BACnet IP	•	•	•	•	•	•	•	•	•	•	•	•	
		Remote LAN connection	•	•	•	•	•	•	•	•	•	•	•	•	
		Container transport						•	•	•	•	•	•	•	
		Refrigerant gauge						•	•	•	•	•	•	•	

1) The system may be supplied without a pump, but in order to meet EU ErP compliance, the installation must include a variable speed pump.

2) Fixed speed pump drive on cooling only chiller, is only suitable installation outside if the EU due to ErP compliance.

3) Constant differential pump drive option is only available on a special order and requires additional production time. Please contact your local sales representative.

4) High pressure fan is not available on model 20 due to body design.

5) Power supply without neutral is only available on a special order and requires additional production time. Please contact your local sales representative.



**Options table 140 - 210**

Option	Type	Ref.	Description	Model				
				140	150	170	190	210
1	Capacity			140	150	170	190	210
2	Refrigerant & compressor type	W	R410A fixed speed	•	•	•	•	•
3	Buffer tank option	NB	No buffer	Std	Std	Std	Std	Std
		BL	Buffer tank (large)	•	•	•	•	•
4	Pump option		No pump <sup>1)</sup>	Std	Std	Std	Std	Std
			Single pump low pressure	•	•	•	•	•
			Single pump high pressure	•	•	•	•	•
			Double pump low pressure	•	•	•	•	•
			Double pump high pressure	•	•	•	•	•
			Pump drive - fixed speed <sup>2)</sup>	Std	Std	Std	Std	Std
			Pump drive - variable twin speed (single pump)	•	•	•	•	•
			Pump drive - variable twin speed (double pump)	•	•	•	•	•
5	Pump drive option		Pump drive - variable capacity (single pump)	•	•	•	•	•
			Pump drive - variable capacity (double pump)	•	•	•	•	•
			Pump drive - constant outlet pressure (single pump)	•	•	•	•	•
			Pump drive - constant outlet pressure (double pump)	•	•	•	•	•
			Pump drive - constant differential pressure (single pump) <sup>3)</sup>	SO	SO	SO	SO	SO
			Pump drive - constant differential pressure (double pump) <sup>3)</sup>	SO	SO	SO	SO	SO
			No hydraulic option	Std	Std	Std	Std	Std
			Low water pressure sensor	•	•	•	•	•
6	Hydraulic options		Water isolation valves	•	•	•	•	•
			Hydraulic gauges	•	•	•	•	•
			No ambient options	Std	Std	Std	Std	Std
			Finned coil treatment - epoxy	•	•	•	•	•
7	Ambient options		Outdoor coil protection grid	•	•	•	•	•
			Rubber pads	•	•	•	•	•
			Spring damper	•	•	•	•	•
			Fan speed control (FSC)	•	•	•	•	•
			Low noise	Std	Std	Std	Std	Std
			High pressure fan	•	•	•	•	•
			No miscellaneous options	Std	Std	Std	Std	Std
			Soft starter	•	•	•	•	•
8	Miscellaneous options		Power supply w/o neutral	•	•	•	•	•
			Standard BMS Option (Modbus RTU)	Std	Std	Std	Std	Std
			Modbus TCP/IP	•	•	•	•	•
			BACnet IP	•	•	•	•	•
			Remote LAN connection	Std	Std	Std	Std	Std
			Refrigerant gauge	•	•	•	•	•

1) The system may be supplied without a pump, but in order to meet EU ERP compliance, the installation must include a variable speed pump.

2) Fixed speed pump drive on cooling only chiller, is only suitable installation outside if the EU due to ERP compliance.

3) Constant differential pump drive option is only available on a special order and requires additional production time. Please contact your local sales representative.

## Fan coils highlighted features

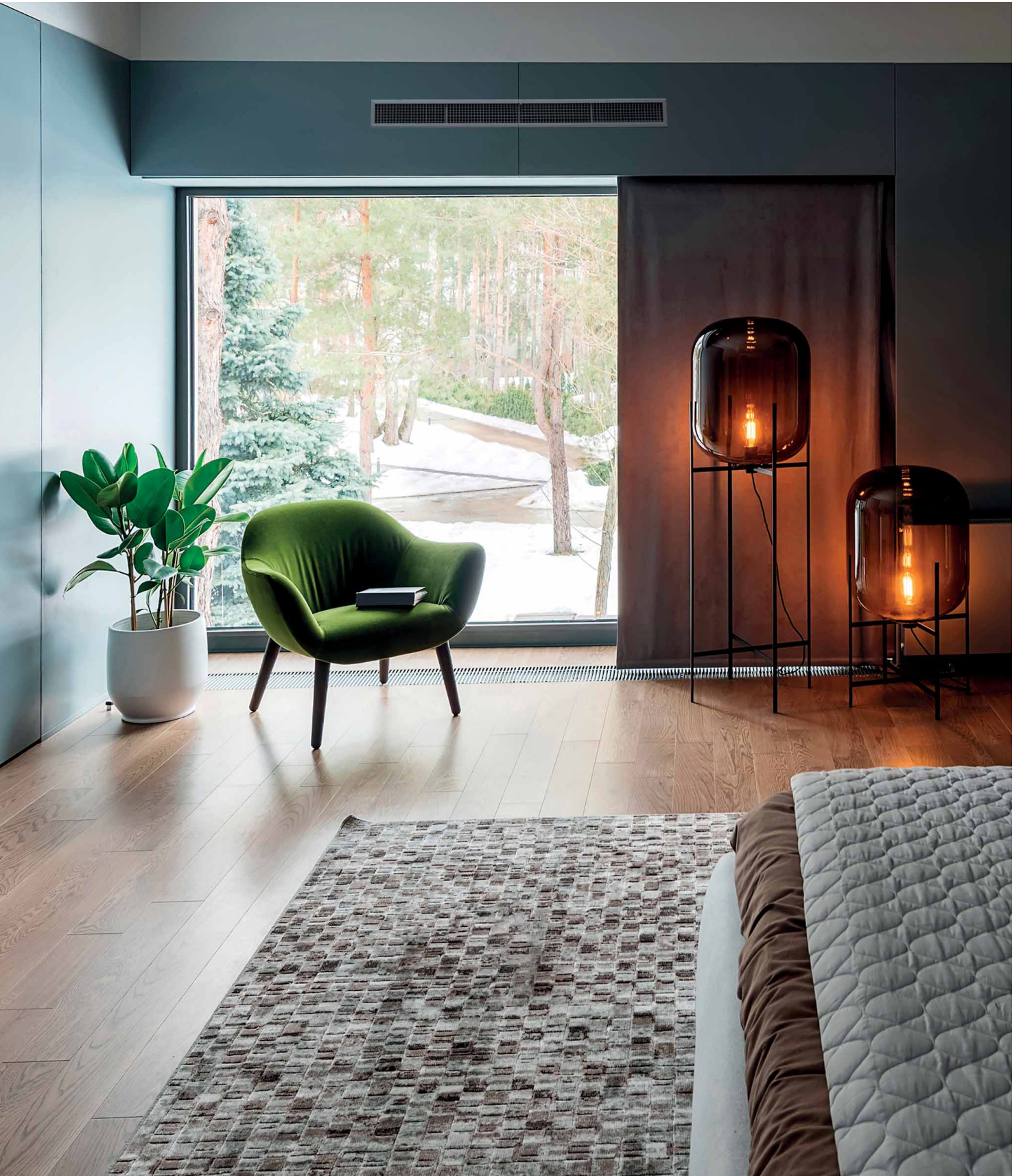

Fan coils: Designed with user in mind, perfectly designed to adapt to any installation. Providing comfort to hotels, shops, restaurants, offices or residential applications.



## 1 Innovation for an optimum comfort

Range of fan coil for heating and cooling with capacities from 0,5 to 21,9 kW in cooling and from 0,6 to 21,5 kW in heating. Bring full year comfort with water based systems.

## 3 Quality and efficient coil

Constructed from staggered copper tubes, mechanically expanded into aluminium fins, providing maximum heat transfer efficiency, durability and hygiene.

## 2 Energy efficient and low noise fan

Dynamically balanced and specially designed fans, reinforced acoustic insulation and optimized fan speed staging for lower noise levels. Improved efficiency with optional EC fan motor.

## 4 Flexible installation

Various types of unit to fit your needs with flexible installation options. A choice of service side for hydraulic connections, piping configuration and horizontal or vertical installation for ducted units.

Offering a great range of capacities and performance, presented in a wide range of designs, the fan coils are perfectly adapted to fit within almost any location. Whether the requirements are for cooling only, or for both heating and cooling, there is a fan coil to suit. With a variety of piping and fan configuration, the range is capable of meeting the most stringent of requirement. Consisting of both AC and EC fans, it is possible to achieve both powerful performance, but with sustainability in mind.

Wide range of controllers with sophisticated designs, provide a user friendly interface while enabling an easy and low cost integration to building management systems.



**PAW-FC-RC1**  
Optional wired remote controller for AC fan, 2-pipe and 4-pipe application.



**PAW-FC-TC903**  
Optional wired remote controller for AC fan 2-pipe application.



**PAW-FC-907TC**  
Optional wired remote controller for EC fan, 2-pipe and 4-pipe application.

# Range of fan coils

Page	Fan Type	Operation	Capacity range	0 kW	1 kW	2 kW	3 kW	4 kW
<b>P. 232</b> 	AC	Cooling	0,7 to 8,1 kW		[Blue bar from 1 to 4 kW]			
		Heating	0,7 to 10,3 kW		[Red bar from 1 to 4 kW]			
	EC	Cooling	0,5 to 9,6 kW		[Blue bar from 1 to 4 kW]			
		Heating	0,6 to 13,6 kW		[Red bar from 1 to 4 kW]			
<b>P. 234</b> 	AC	Cooling	4,1 to 21,9 kW					[Blue bar from 4 to 4 kW]
		Heating	4,7 to 21,5 kW					[Red bar from 4 to 4 kW]
	EC	Cooling	6,6 to 21,4 kW					
		Heating	5,9 to 21,4 kW					
<b>P. 236</b> 	AC	Cooling	1.4 to 8,6 kW		[Blue bar from 1 to 4 kW]			
		Heating	1,1 to 12,8 kW		[Red bar from 1 to 4 kW]			
	EC	Cooling	1,4 to 9,4 kW		[Blue bar from 1 to 4 kW]			
		Heating	1,1 to 14,0 kW		[Red bar from 1 to 4 kW]			
<b>P. 238</b> 	AC	Cooling	0,7 to 8,1 kW		[Blue bar from 1 to 4 kW]			
		Heating	0,7 to 10,3 kW		[Red bar from 1 to 4 kW]			
	EC	Cooling	0,5 to 9,6 kW		[Blue bar from 1 to 4 kW]			
		Heating	0,6 to 13,6 kW		[Red bar from 1 to 4 kW]			
<b>P. 240</b> 	AC	Cooling	0,7 to 8,1 kW		[Blue bar from 1 to 4 kW]			
		Heating	0,7 to 10,3 kW		[Red bar from 1 to 4 kW]			
	EC	Cooling	0,5 to 9,6 kW		[Blue bar from 1 to 4 kW]			
		Heating	0,6 to 13,6 kW		[Red bar from 1 to 4 kW]			
<b>P. 242</b> 	AC	Cooling	1.0 to 3,9 kW		[Blue bar from 1 to 3 kW]			
		Heating	1,4 to 4,1 kW		[Red bar from 1 to 3 kW]			

Values indicated are for the full operating range. The data shown within the tables following are indicative of specific installation conditions. For full details relating to performance and operating conditions, please refer to the technical data manual.

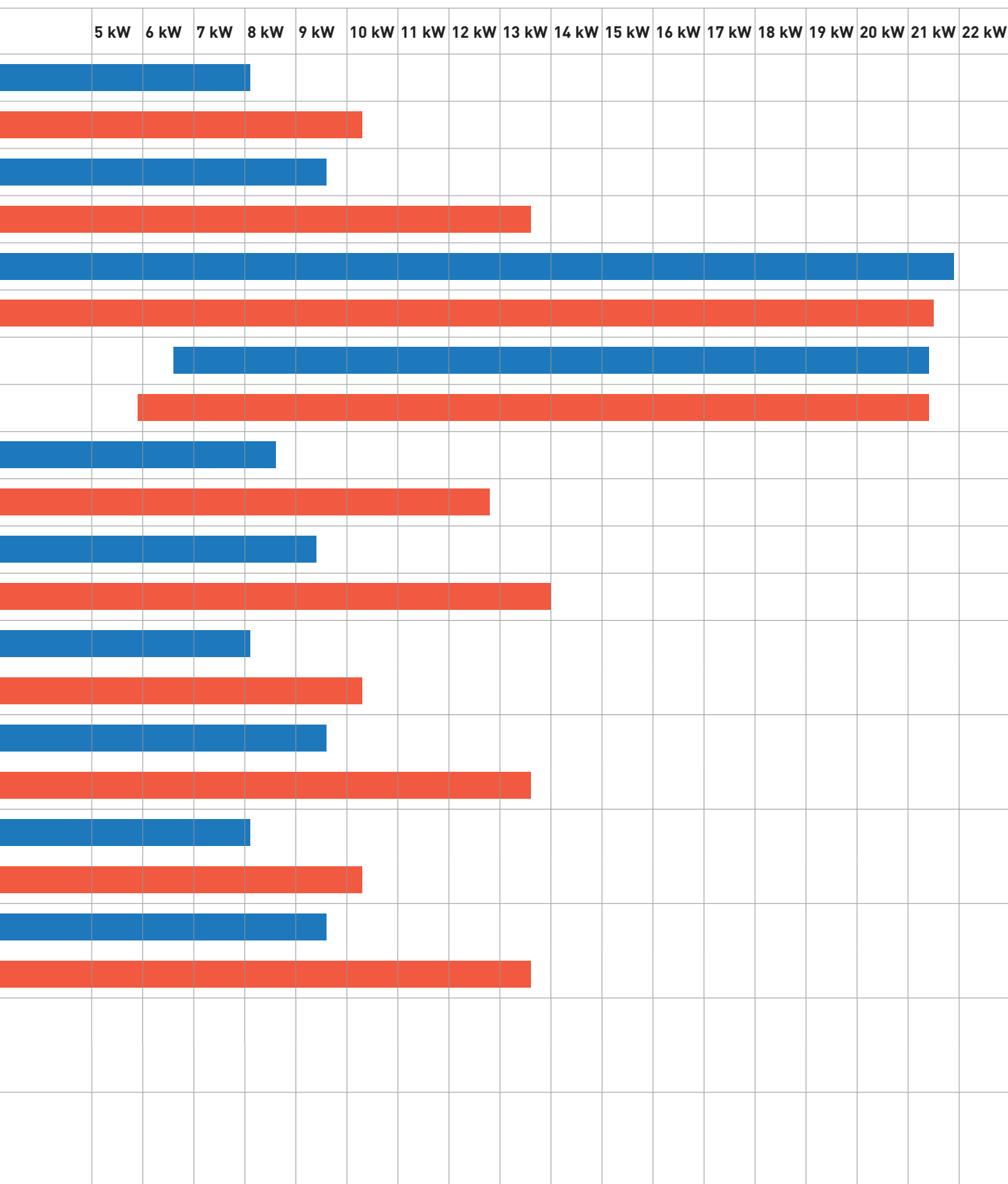



**PAW-FC-903TC**  
Optional Controller.  
Wired remote controller.



**PAW-FC-RC1**  
Optional Controller.  
Advanced wired remote controller.

**Fan coils - Ducted (AC)**

PAW-			FC-D11-1(-R)	FC-D15-1(-R)	FC-D24-1(-R)	FC-D28-1(-R)	FC-D40-1(-R)	FC-D55-1(-R)	FC-D65-1(-R)	FC-D90-1(-R)
<b>2-pipe</b>	Left connection (PAW-)*		FC2A-D010L	FC2A-D020L	FC2A-D030L	FC2A-D040L	FC2A-D050L	FC2A-D060L	FC2A-D070L	FC2A-D080L
	Right connection (PAW-)*		FC2A-D010R	FC2A-D020R	FC2A-D030R	FC2A-D040R	FC2A-D050R	FC2A-D060R	FC2A-D070R	FC2A-D080R
Total cooling capacity <sup>1)</sup>	Med / S-Hi	kW	1,0/1,5	1,2/1,7	2,0/2,5	2,4/3,2	3,2/4,6	4,6/5,8	6,1/7,3	6,1/8,1
Sensible capacity <sup>1)</sup>	Med / S-Hi	kW	0,8/1,1	0,9/1,3	1,5/1,9	1,8/2,3	2,2/3,3	3,3/4,5	4,3/5,1	4,6/6,3
Water flow	Med / S-Hi	l/h	172/250	213/289	341/430	413/547	544/798	784/1003	1058/1252	1048/1400
Water pressure drop	Med / S-Hi	kPa	19,5/39,2	3,9/6,3	19,3/28,8	17,1/28,0	22,8/46,9	37,4/60,2	15,4/21,5	19,3/32,5
Heating capacity <sup>2)</sup>	Med / S-Hi	kW	1,4/2,0	1,5/2,2	2,4/3,1	2,9/4,0	4,1/5,7	5,3/7,1	7,9/9,3	8,1/11,6
<b>4-pipe</b>	Left connection (PAW-)		FC4A-D010L	FC4A-D020L	FC4A-D030L	FC4A-D040L	FC4A-D050L	FC4A-D060L	FC4A-D070L	FC4A-D080L
	Right connection (PAW-)		FC4A-D010R	FC4A-D020R	FC4A-D030R	FC4A-D040R	FC4A-D050R	FC4A-D060R	FC4A-D070R	FC4A-D080R
Total cooling capacity <sup>1)</sup>	Med / S-Hi	kW	0,9/1,3	1,1/1,6	1,9/2,4	2,3/3,0	3,0/4,3	4,4/5,6	5,9/6,9	5,9/8,0
Sensible capacity <sup>1)</sup>	Med / S-Hi	kW	0,7/1,0	0,8/1,2	1,5/1,8	1,7/2,2	2,2/3,1	3,2/4,3	4,2/4,9	4,4/6,2
Water flow	Med / S-Hi	l/h	159/225	192/268	327/414	388/517	522/748	756/967	1019/1193	1020/1380
Water pressure drop	Med / S-Hi	kPa	15,2/29,0	3,4/5,6	9,5/14,4	22,3/36,8	12,8/25,1	27,7/44,5	17,9/24,4	31,1/53,6
Heating capacity <sup>2)</sup>	Med / S-Hi	kW	0,7/1,0	0,9/1,1	1,4/1,6	1,6/2,1	2,3/2,6	2,9/3,3	3,6/4,0	5,6/6,1
Water flow	Med / S-Hi	l/h	127/178	146/190	232/274	273/354	401/443	505/560	626/682	963/1052
Water pressure drop	Med / S-Hi	kPa	3,5/5,6	3,2/5,3	9,0/11,9	26,5/42,7	24,6/29,5	43,9/52,9	117,9/137,8	63,7/75
<b>Sound levels</b>										
Global sound power level	S-Lo / Med / S-Hi	dB(A)	33/40/49	31/43/50	30/45/52	30/44/51	34/46/56	38/51/58	43/56/61	50/55/64
Global sound pressure level <sup>3)</sup>	S-Lo / Med / S-Hi	dB(A)	24/31/40	22/34/41	21/36/43	21/35/42	25/37/47	29/42/49	34/47/52	41/46/55
<b>Fan</b>										
Number			1	1	1	2	2	2	2	3
Air flow 2-pipe	Med / S-Hi	m <sup>3</sup> /h	190/283	179/265	274/390	357/499	486/716	640/933	893/1064	936/1397
Air flow 4-pipe	Med / S-Hi	m <sup>3</sup> /h	168/253	161/241	263/369	335/467	466/542	614/723	859/944	905/1042
Maximum external pressure		Pa	55	55	65	85	85	115	125	70
Filter			G2	G2	G2	G2	G2	G2	G2	G2
<b>Electrical data</b>										
Power supply	Voltage	V	230	230	230	230	230	230	230	230
	Phase		Single Phase	Single Phase	Single Phase	Single Phase	Single Phase	Single Phase	Single Phase	Single Phase
	Frequency	Hz	50/60	50/60	50/60	50/60	50/60	50/60	50/60	50/60
Power consumption 2-pipe	Med / S-Hi	W	24/36	18/29	37/45	37/56	55/72	75/105	100/147	112/188
Power consumption 4-pipe	Med / S-Hi	W	24/36	18/28	37/44	37/55	54/70	74/104	99/145	112/188
<b>Water connections</b>										
Type			Female gas threaded	Female gas threaded	Female gas threaded	Female gas threaded	Female gas threaded	Female gas threaded	Female gas threaded	Female gas threaded
2-pipe		Inch	1/2	1/2	1/2	1/2	1/2	1/2	3/4	3/4
	Cooling	Inch	1/2	1/2	1/2	1/2	1/2	1/2	3/4	3/4
4-pipe	Heating	Inch	1/2	1/2	1/2	1/2	1/2	1/2	1/2	1/2
<b>Dimensions and weight</b>										
Dimensions	H x W x D	mm	430 x 220 x 570	430 x 220 x 570	430x 220 x 730	430 x 220 x 938	430 x 220 x 1122	430 x 220 x 1307	530 x 220 x 1121	530 x 220 x 1316
Weight	2 / 4-pipes	kg	13/14	13/14	15/16	20/22	22/24	26/28	27/29	38/40

1) According to Eurovent standard. Air: 27 °C DB / 19 °C WB. Water in/ out: 7 °C / 12 °C. 2) Air: 20 °C. Water in/out: 50 °C / 45 °C. 3) The sound pressure levels are based on (NR) characteristics of a room having volume of 100 m<sup>3</sup> with reverberation of 0,5 seconds.  
Values indicated are for 0 Pa external static pressure, for additional pressure characteristics, please refer the technical data manual.  
\* Fan coil references valid from October 2020.

**Technical focus**

- Cooling capacity from 0,7 to 8,1 kW
- Heating capacity from 0,7 to 10,3 kW
- 5-speed AC fan motor(s)

**Main features and accessories**

- 2 and 4-pipe configurations
- Left or right hand arrangements
- Ease of installation
- Very low acoustic levels
- 2 way or 3 way ON/OFF valves
- Auxiliary drain pan
- Air intake with removable grid
- G2 filter

<b>Operating limits</b>	
Entering water temperature	From 5 to 90 °C
Indoor air temperature	From 5 to 32 °C



ERP 2018: compliant following COMMISSION REGULATION (EU) No2016/2281.





PAW-FC-907TC  
Optional Controller.  
Wired remote  
controller for EC fans.

### Fan coils - Ducted (EC)

2-pipe	Left connection (PAW-)		FC2E-D010L	FC2E-D020L	FC2E-D030L	FC2E-D040L	FC2E-D050L	FC2E-D060L	FC2E-D070L	FC2E-D080L	FC2E-F040L
	Right connection (PAW-)		FC2E-D010R	FC2E-D020R	FC2E-D030R	FC2E-D040R	FC2E-D050R	FC2E-D060R	FC2E-D070R	FC2E-D080R	FC2E-F040R
Total cooling capacity <sup>1)</sup>	Med / S-Hi	kW	1,2/2,1	1,4/2,4	2,1/3,1	2,9/4,2	4,0/5,0	4,5/5,2	5,9/6,9	6,5/8,8	6,6/9,2
Sensible capacity <sup>1)</sup>	Med / S-Hi	kW	1,1/1,9	1,1/1,9	1,6/2,4	2,1/3,0	3,0/3,7	3,5/4,0	4,3/5,2	4,8/6,6	6,1/9,1
Water flow	Med / S-Hi	l/h	210/356	237/406	354/532	506/722	685/743	767/800	1008/1098	1111/1254	1284/1935
Water pressure drop	Med / S-Hi	kPa	28,2/76,9	4,6/11,0	20,5/42,1	24,4/46,3	35,1/41,0	35,8/38,8	14,0/16,6	21,4/26,6	51,2/93,8
Heating capacity <sup>2)</sup>	Med / S-Hi	kW	1,6/2,9	1,9/3,3	2,2/3,4	3,0/5,3	5,2/5,5	5,9/6,1	7,3/8,2	8,0/9,3	8,3/11,8
4-pipe	Left connection (PAW-)		FC4E-D010L	FC4E-D020L	FC4E-D030L	FC4E-D040L	FC4E-D050L	FC4E-D060L	FC4E-D070L	FC4E-D080L	FC4E-F040L
	Right connection (PAW-)		FC4E-D010R	FC4E-D020R	FC4E-D030R	FC4E-D040R	FC4E-D050R	FC4E-D060R	FC4E-D070R	FC4E-D080R	FC4E-F040R
Total cooling capacity <sup>1)</sup>	Med / S-Hi	kW	1,1/1,9	1,2/2,2	1,9/2,9	2,7/4,0	3,6/4,6	4,1/4,9	5,1/6,4	6,2/9,6	6,4/8,8
Sensible capacity <sup>1)</sup>	Med / S-Hi	kW	0,9/1,7	1,0/1,8	1,5/2,2	1,9/2,8	2,8/3,5	3,2/3,8	3,8/4,8	4,6/7,2	5,6/8,0
Water flow	Med / S-Hi	l/h	185/327	206/375	321/493	457/681	625/686	707/749	886/977	1070/1242	1093/1511
Water pressure drop	Med / S-Hi	kPa	20,1/59,2	3,7/9,7	9,2/19,7	29,6/60,1	17,9/21,3	24,3/27,2	13,6/16,5	33,9/44,3	47,2/86,7
Heating capacity <sup>2)</sup>	Med / S-Hi	kW	0,8/1,4	0,9/1,5	1,4/1,8	2,0/2,8	2,4/2,5	2,9/3,1	3,4/3,6	5,9/6,9	4,5/6,2
Water flow	Med / S-Hi	l/h	140/235	161/255	243/304	350/483	416/438	503/531	583/614	1011/1194	783/1065
Water pressure drop	Med / S-Hi	kPa	4,0/8,4	3,8/9,4	9,7/14,1	41,8/76,3	26,3/28,9	43,6/48,1	103,8/113,9	69,7/95,1	107,6/214,8
Sound levels											
Global sound power level	S-Lo / Med / S-Hi	dB(A)	34/47/60	34/47/60	31/50/59	29/44/52	30/51/57	32/54/58	40/54/59	51/56/64	42/58/68 <sup>3)</sup>
Global sound pressure level <sup>4)</sup>	S-Lo / Med / S-Hi	dB(A)	25/38/51	25/38/51	22/41/50	20/35/43	21/42/48	23/45/49	31/45/50	42/47/55	23/39/52
Fan											
Number			1	1	1	2	2	2	2	3	1
Air flow 2-pipe	Med / S-Hi	m <sup>3</sup> /h	228/417	234/413	380/585	412/678	645/702	737/779	850/950	927/1093	1284/1935
Air flow 4-pipe	Med / S-Hi	m <sup>3</sup> /h	199/379	200/380	342/540	369/627	587/646	668/716	798/894	884/1079	1222/1864
Maximum external pressure		Pa	75	75	75	105	70	105	115	115	190
Filter			G2	G2	G2	G2	G2	G2	G2	G2	G2
Electrical data											
Power supply	Voltage	V	230	230	230	230	230	230	230	230	230
	Phase		Single Phase	Single Phase	Single Phase	Single Phase	Single Phase	Single Phase	Single Phase	Single Phase	Single Phase
	Frequency	Hz	50/60	50/60	50/60	50/60	50/60	50/60	50/60	50/60	50/60
Power consumption 2-pipe	Med / S-Hi	W	11/41	13/41	16/42	13/43	24/46	30/54	44/77	42/108	62/197
Power consumption 4-pipe	Med / S-Hi	W	11/39	13/40	15/40	12/42	23/44	28/52	43/75	41/116	60/188
Water connections											
Type			Female gas threaded	Female gas threaded	Female gas threaded	Female gas threaded	Female gas threaded	Female gas threaded	Female gas threaded	Female gas threaded	Female gas threaded
2-pipe		Inch	1/2	1/2	1/2	1/2	1/2	1/2	3/4	3/4	3/4
	Cooling	Inch	1/2	1/2	1/2	1/2	1/2	1/2	3/4	3/4	3/4
4-pipe		Inch	1/2	1/2	1/2	1/2	1/2	1/2	1/2	1/2	1/2
	Heating	Inch	1/2	1/2	1/2	1/2	1/2	1/2	1/2	1/2	1/2
Dimensions and weight											
Dimensions	H x W x D	mm	430 x 220 x 570	430 x 220 x 570	430 x 220 x 730	430 x 220 x 938	430 x 220 x 1122	430 x 220 x 1307	530 x 220 x 1121	530 x 220 x 1316	223 x 653 x 1233
Weight	2 / 4-pipes	kg	13/14	13/14	15/16	20/22	22/24	26/28	27/29	38/40	19/19

1) According to Eurovent standard. Air: 27 °C DB / 19 °C WB. Water in/ out: 7 °C / 12 °C. 2) Air: 20 °C. Water in/out: 50 °C / 45 °C. 3) The sound power levels indicated are from return and radiated measurements. 4) The sound pressure levels are based on [NR] characteristics of a room having volume of 100 m<sup>3</sup> with reverberation of 0,5 seconds. Values indicated are for 0 Pa external static pressure, for additional pressure characteristics, please refer the technical data manual.

### Technical focus

- Cooling capacity from 0,5 to 9,6 kW
- Heating capacity from 0,6 to 13,6 kW
- Low energy consumption EC fan(s)

### Main features and accessories

- 2 and 4-pipe configurations
- Left or right hand arrangements
- Can be installed both horizontally and vertically\*
- Ease of installation
- Very low acoustic levels
- 2 way or 3 way ON/OFF valves
- Auxiliary drain pan
- Air intake with removable grid
- G2 filter



ERP 2018: compliant following COMMISSION REGULATION (EU) No2016/2281.

### Operating limits

Entering water temperature	From 5 to 90 °C
Indoor air temperature	From 5 to 32 °C

\* PAW-FC2E-F040 and PAW-FC4E-F040 may only be installed horizontally.



**PAW-FC-903TC**  
Optional Controller.  
Wired remote controller.



**PAW-FC-RC1**  
Optional Controller.  
Advanced wired remote controller.

**Fan coils - High Static Pressure Ducted (AC)**

2-pipe	Left connection		PAW-FC2A-E070L	PAW-FC2A-E150L	PAW-FC2A-E180L	PAW-FC2A-E210L	PAW-FC2A-E240L*	PAW-FC2A-E270L*
	Right connection		PAW-FC2A-E070R	PAW-FC2A-E150R	PAW-FC2A-E180R	PAW-FC2A-E210R	PAW-FC2A-E240R*	PAW-FC2A-E270R*
Total cooling capacity <sup>1)</sup>	Med / S-Hi	kW	5,5/6,4	11,5/14,2	11,5/15,0	13,7/18,6	19,8/23,3	23,0/27,5
Sensible capacity <sup>1)</sup>	Med / S-Hi	kW	4,2/5,1	9,2/12,2	9,5/13,1	9,9/13,7	14,9/17,8	16,3/19,7
Water flow	Med / S-Hi	l/h	951/1095	1979/2437	1979/2589	2357/3201	3410/4015	3951/4740
Water pressure drop	Med / S-Hi	kPa	42,5/56,2	19,9/29,3	19,6/32,0	28,8/51,5	25,2/34,2	25,2/35,3
Heating capacity <sup>2)</sup>	Med / S-Hi	kW	8,6/12,7	14,2/20,0	16,3/23,2	16,5/23,4	26,3/32,6	27,5/33,7
4-pipe	Left connection		PAW-FC4A-E070L	PAW-FC4A-E150L	PAW-FC4A-E180L	PAW-FC4A-E210L	PAW-FC4A-E240L*	PAW-FC4A-E270L*
	Right connection		PAW-FC4A-E070R	PAW-FC4A-E150R	PAW-FC4A-E180R	PAW-FC4A-E210R	PAW-FC4A-E240R*	PAW-FC4A-E270R*
Total cooling capacity <sup>1)</sup>	Med / S-Hi	kW	5,4/6,0	10,1/11,9	11,2/13,6	14,4/18,8	17,7/20,5	19,9/23,4
Sensible capacity <sup>1)</sup>	Med / S-Hi	kW	4,1/4,7	8,4/10,9	9,1/12,0	10,6/14,5	13,9/16,3	14,9/17,8
Water flow	Med / S-Hi	l/h	924/1035	1739/2044	1928/2335	2478/3241	3053/3526	3427/4032
Water pressure drop	Med / S-Hi	kPa	52,1/64,4	13,5/18,4	17,4/25,0	35,2/59,1	25,0/33,0	23,3/31,5
Heating capacity <sup>2)</sup>	Med / S-Hi	kW	6,0/7,4	11,8/15,9	11,9/15,9	11,9/16,0	11,1/13,5	11,1/13,5
Water flow	Med / S-Hi	l/h	1029/1266	2038/2746	2045/2745	2051/2747	1910/2329	1910/2329
Water pressure drop	Med / S-Hi	kPa	30,7/43,6	167,6/293,0	100,8/174,3	101,4/174,6	87,8/120,3	53,3/72,5
<b>Sound levels</b>								
Sound power return + radiated	S-Lo / Med / S-Hi	dB(A)	54/60/63	52/66/72	54/66/74	52/66/72	65/73/75	65/73/75
Sound power discharge	S-Lo / Med / S-Hi	dB(A)	53/59/62	52/64/71	52/64/71	52/64/71	64/72/75	64/72/75
Sound pressure <sup>3)</sup>	S-Lo / Med / S-Hi	dB(A)	33/39/42	31/45/51	31/45/51	31/45/51	44/52/54	44/52/54
<b>Fan</b>								
Number	1							
Air flow 2-pipe	Med / S-Hi	m <sup>3</sup> /h	1091/1562	2110/3197	2110/3197	2110/3197	3130/3923	3130/3923
Air flow 4-pipe	Med / S-Hi	m <sup>3</sup> /h	1132/1496	2110/3197	2110/3197	2110/3197	3130/3923	3130/3923
Maximum external pressure		Pa	110	200	200	200	220	220
Filter			G3	G3	G3	G3	G3	G3
<b>Electrical data</b>								
Power supply	Voltage	V	230	230	230	230	230	230
	Phase		Single Phase	Single Phase	Single Phase	Single Phase	Single Phase	Single Phase
	Frequency	Hz	50/60	50/60	50/60	50/60	50/60	50/60
Power consumption	Med / S-Hi	W	182/222	421/675	421/675	421/675	530/673	530/673
<b>Water connections</b>								
Type			Female gas threaded	Gas Male threaded	Gas Male threaded	Gas Male threaded	Gas Male threaded	Gas Male threaded
2-pipe		Inch	1/2	1	1 1/4	1 1/4	1 1/4	1 1/4
4-pipe	Cooling	Inch	1/2	1	1	1	1 1/4	1 1/4
	Heating	Inch	1/2	3/4	3/4	3/4	3/4	3/4
<b>Dimensions and weight</b>								
Dimensions	H x W x D	mm	250 x 698 x 1200	375 x 798 x 1380	375 x 798 x 1380	375 x 798 x 1380	450 x 798 x 1500	450 x 798 x 1500
Weight		kg	42	63	65	67	76	80

1) According to Eurovent standard. Air: 27 °C DB / 19 °C WB. Water in/ out: 7 °C / 12 °C. 2) Air: 20 °C. Water in/out: 50 °C / 45 °C. 3) Informative data: Considering an hypothetical sound attenuation of the room and installation of 21 dB.

Values indicated are for 50 Pa external static pressure, for additional pressure characteristics, please refer the technical data manual.

\* High fan speed used for capacity, water flow, sound and airflow values.

**Technical focus**

- 6 sizes
- Cooling capacity from 4,1 to 21,9 kW
- Heating capacity from 4,7 to 21,5 kW
- 5-speed AC fan motor

**Main features and accessories**

- 2 and 4-pipe, left & right hand configurations
- Static pressure up to 220Pa
- Double skin insulation
- 2 way or 3 way ON/OFF valves
- Auxiliary drain pan
- Air intake with removable grid
- G3 filter

**Operating limits**

Entering water temperature	From 5 to 90 °C
Indoor air temperature	From 5 to 32 °C





**PAW-FC-907TC**  
Optional Controller.  
Wired remote  
controller for EC fans.

## Fan coils - High Static Pressure Ducted (EC)

2-pipe	Left connection		PAW-FC2E-E150L	PAW-FC2E-E180L	PAW-FC2E-E210L	PAW-FC2E-E240L	PAW-FC2E-E270L
	Right connection		PAW-FC2E-E150R	PAW-FC2E-E180R	PAW-FC2E-E210R	PAW-FC2E-E240R	PAW-FC2E-E270R
Total cooling capacity <sup>1)</sup>	Med / S-Hi	kW	11,3/14,5	13,1/17,3	14,2/19,0	16,1/20,3	18,1/23,1
Sensible capacity <sup>1)</sup>	Med / S-Hi	kW	9,1/12,1	10,3/14,1	10,9/15,0	12,4/16,2	13,6/17,8
Water flow	Med / S-Hi	l/h	1945/2498	2259/2979	2451/3275	2766/3498	3120/3972
Water pressure drop	Med / S-Hi	kPa	19,3/30,7	24,9/41,5	31,0/53,8	17,1/26,4	16,4/25,4
Heating capacity <sup>2)</sup>	Med / S-Hi	kW	15,8/20,7	17,9/24,3	19,4/26,8	20,8/27,5	22,8/30,4
4-pipe	Left connection		PAW-FC4E-E150L	PAW-FC4E-E180L	PAW-FC4E-E210L	PAW-FC4E-E240L	PAW-FC4E-E270L
	Right connection		PAW-FC4E-E150R	PAW-FC4E-E180R	PAW-FC4E-E210R	PAW-FC4E-E240R	PAW-FC4E-E270R
Total cooling capacity <sup>1)</sup>	Med / S-Hi	kW	9,1/11,6	10,2/13,0	12,6/16,4	14,0/17,5	15,3/19,5
Sensible capacity <sup>1)</sup>	Med / S-Hi	kW	7,6/10,1	8,4/11,2	9,9/13,4	11,0/14,2	11,8/15,5
Water flow	Med / S-Hi	l/h	1567/2005	1764/2243	2175/2826	2409/3020	2641/3359
Water pressure drop	Med / S-Hi	kPa	11,1/17,7	14,7/23,2	27,5/45,4	15,9/24,5	14,5/22,4
Heating capacity <sup>2)</sup>	Med / S-Hi	kW	5,8/7,3	10,0/12,8	10,1/12,9	8,3/10,3	8,2/10,5
Water flow	Med / S-Hi	l/h	991/1264	1729/2211	1734/2227	1421/1780	1407/1804
Water pressure drop	Med / S-Hi	kPa	45,6/70,1	74,1/116,4	74,5/118,0	55,9/78,7	33,9/48,9
<b>Sound levels</b>							
Sound power return + radiated	S-Lo / Med / S-Hi	dB(A)	56/67/74	56/67/74	56/67/74	58/69/76	58/69/76
Sound power discharge	S-Lo / Med / S-Hi	dB(A)	56/65/74	56/65/74	56/65/74	58/67/76	58/67/76
Sound pressure <sup>3)</sup>	S-Lo / Med / S-Hi	dB(A)	35/46/52	35/46/52	35/46/52	37/48/54	37/48/54
<b>Fan</b>							
Number	1						
Air flow 2-pipe	Med / S-Hi	m <sup>3</sup> /h	2418/3583	2418/3583	2418/3583	2700/3829	2700/3829
Air flow 4-pipe	Med / S-Hi	m <sup>3</sup> /h	2418/3583	2418/3583	2418/3583	2700/3829	2700/3829
Maximum external pressure		Pa	300	300	300	300	300
<b>Electrical data</b>							
	Voltage	V					
Power supply	Phase		Single Phase	Single Phase	Single Phase	Single Phase	Single Phase
	Frequency	Hz	50/60	50/60	50/60	50/60	50/60
Power consumption	Med / S-Hi	W	172/246	172/246	172/246	237/364	237/364
<b>Water connections</b>							
Type			Gas Male threaded	Gas Male threaded	Gas Male threaded	Gas Male threaded	Gas Male threaded
2-pipe		Inch	1	1 1/4	1 1/4	1 1/4	1 1/4
4-pipe	Cooling	Inch	1	1	1	1 1/4	1 1/4
	Heating	Inch	3/4	3/4	3/4	3/4	3/4
<b>Dimensions and weight</b>							
Dimensions	H x W x D	mm	375 x 798 x 1380	375 x 798 x 1380	375 x 798 x 1380	450 x 798 x 1500	450 x 798 x 1500
Weight		kg	63	65	67	76	80

1) According to Eurovent standard. Air: 27 °C DB / 19 °C WB. Water in/ out: 7 °C / 12 °C. 2) Air: 20 °C. Water in/out: 50 °C / 45 °C. 3) Informative data: Considering an hypothetical sound attenuation of the room and installation of 21 dB.

Values indicated are for 50 Pa external static pressure, for additional pressure characteristics, please refer the technical data manual.

### Technical focus

- 5 sizes
- Cooling capacity from 6,6 to 19,9 kW
- Heating capacity from 5,9 to 21,4 kW
- Low energy consumption EC fan

### Main features and accessories

- 2 and 4-pipe, left & right hand configurations
- Static pressure up to 300Pa
- Double skin insulation
- 2 way or 3 way ON/OFF valves
- Auxiliary drain pan
- Air intake with removable grid
- G3 filter

### Operating limits

Entering water temperature	From 5 to 90 °C
Indoor air temperature	From 5 to 32 °C



ERP 2018: compliant following COMMISSION REGULATION (EU) No2016/2281.



**PAW-FC-903TC**  
Optional Controller.  
Wired remote controller.



**PAW-FC-RC1**  
Optional Controller.  
Advanced wired remote controller.

## Fan coils - 4 Way Cassette (AC)

2-pipe			PAW-FC2A-U020	PAW-FC2A-U030	PAW-FC2A-U040	PAW-FC2A-U050	PAW-FC2A-U060	PAW-FC2A-U070
Total cooling capacity <sup>1)</sup>	Med / Hi	kW	1,8/2,4	2,7/4,0	3,5/4,7	4,4/6,1	5,4/7,2	6,5/8,6
Sensible capacity <sup>1)</sup>	Med / Hi	kW	1,5/2,0	2,2/3,0	2,6/3,6	3,4/4,8	4,0/5,4	4,8/6,4
Water flow	Med / Hi	l/h	303/404	493/683	597/801	762/1042	937/1233	1111/1476
Water pressure drop	Med / Hi	kPa	6,8/10,9	8,5/14,4	11,2/18,3	13/21,9	7,5/11,5	13/20,5
Heating capacity <sup>2)</sup>	Med / Hi	kW	2,5/3,25	3,7/4,5	4,6/6,2	6,0/8,1	7,4/10,0	9,2/12,0
4-pipe			PAW-FC4A-U020	PAW-FC4A-U030	PAW-FC4A-U040	—	PAW-FC4A-U060	PAW-FC4A-U070
Total cooling capacity <sup>1)</sup>	Med / Hi	kW	1,5/2,0	2,7/3,4	3,3/4,0	—	4,9/6,6	6,0/7,5
Sensible capacity <sup>1)</sup>	Med / Hi	kW	1,4/1,8	2,1/2,6	2,6/3,2	—	3,8/5,1	4,6/5,9
Water flow	Med / Hi	l/h	258/359	465/576	563/683	—	851/1137	1030/1294
Water pressure drop	Med / Hi	kPa	8,9/13,6	8,3/11,6	11,2/15,3	—	13,9/22,2	18,9/27,5
Heating capacity <sup>2)</sup>	Med / Hi	kW	0,9/1,2	3,1/3,8	3,5/4,1	—	5,5/7,0	7,1/8,9
Water flow	Med / Hi	l/h	153/201	530/658	603/699	—	939/1210	1214/1540
Water pressure drop	Med / Hi	kPa	33,4/53,6	24,2/35	30,9/39,8	—	13,8/20,7	20,8/30,9
Sound levels								
Global sound power level 2-pipe	Lo / Med / Hi	dB(A)	36/40/49	35/47/53	42/48/57	35/40/49	38/46/54	40/52/59
Global sound power level 4-pipe	Lo / Med / Hi	dB(A)	36/40/49	35/47/53	42/48/57	—	38/46/54	40/52/59
Global sound pressure level 2-pipe <sup>3)</sup>	Lo / Med / Hi	dB(A)	27/31/40	26/35/44	33/39/48	26/31/40	29/37/45	31/43/50
Global sound pressure level 4-pipe <sup>3)</sup>	Lo / Med / Hi	dB(A)	27/31/40	26/35/44	33/39/48	—	29/37/45	31/43/50
Fan								
Number			1	1	1	1	1	1
Air flow	Med / Hi	m <sup>3</sup> /h	450/659	504/734	626/900	720/979	824/1159	1080/1447
Filter			G1	G1	G1	G1	G1	G1
Electrical data								
Power supply	Voltage	V	230	230	230	230	230	230
	Phase		Single Phase	Single Phase	Single Phase	Single Phase	Single Phase	Single Phase
	Frequency	Hz	50	50	50	50	50	50
Power consumption 2-pipe	Med / Hi	W	35/58	34/58	58/99	41/66	61/88	92/125
Power consumption 4-pipe	Med / Hi	W	35/58	34/58	58/99	—	61/88	92/125
Water connections								
Type			Female gas threaded	Female gas threaded	Female gas threaded	Female gas threaded	Female gas threaded	Female gas threaded
2-pipe		Inch	3/4	3/4	3/4	1	1	1
4-pipe	Cooling	Inch	3/4	3/4	3/4	—	1	1
	Heating	Inch	1/2	1/2	1/2	—	3/4	3/4
Dimensions and weight								
Dimensions including panel	H x W x D	mm	334 x 720 x 720	334 x 720 x 720	334 x 720 x 720	339 x 960 x 960	339 x 960 x 960	339 x 960 x 960
Weight		kg	14,8	16,5	16,5	37,1	37,1	39,6

1) According to Eurovent standard. Air: 27 °C DB / 19 °C WB. Water in/out: 7 °C/12 °C. 2) According to Eurovent standard. Air: 20 °C. Water in/out: 45 °C / 40 °C. 3) Information data considering an hypothetical sound attenuation of the room and installation of -9 dB(A).

### Technical focus

- 6 sizes\*
- Cooling capacity from 1,4 to 8,6 kW
- Heating capacity from 1,1 to 12,8 kW
- 3-speed AC fan motor

### Main features and accessories

- 2 and 4-pipe configurations
- Very low acoustic levels
- Quick access, by simply removing the front grille
- All connections: located at the same side
- Galvanized steel sheet with thermal and acoustical insulation, avoiding condensation on the casing and providing good sound attenuation
- Cleanable synthetic-type air filter

#### Operating limits

Entering water temperature	From 5 to 90 °C
Indoor air temperature	From 5 to 32 °C

\* 5 sizes available for 4-pipe configuration.



ERP 2018: compliant following COMMISSION REGULATION (EU) No2016/2281.



**PAW-FC-907TC**  
Optional Controller.  
Wired remote  
controller for EC fans.

## Fan coils - 4 Way Cassette (EC)

2-pipe			PAW-FC2E-U020	PAW-FC2E-U030	PAW-FC2E-U040	PAW-FC2E-U050	PAW-FC2E-U060	PAW-FC2E-U070
Total cooling capacity <sup>1)</sup>	Med / Hi	kW	1,8/2,4	2,9/4,0	3,5/4,7	4,4/6,1	5,5/7,2	6,5/9,6
Sensible capacity <sup>1)</sup>	Med / Hi	kW	1,5/2,0	2,2/3,1	2,7/3,6	3,5/4,7	4,1/5,4	4,9/7,2
Water flow	Med / Hi	l/h	306/409	497/688	604/808	765/1050	944/1243	1119/1649
Water pressure drop	Med / Hi	kPa	6,9/11,2	8,6/14,6	11,4/18,6	13,1/22,2	7,6/11,7	13,1/24,6
Heating capacity <sup>2)</sup>	Med / Hi	kW	2,5/3,2	3,7/4,5	4,6/6,2	6,0/8,1	7,4/10,0	9,2/13,0
4-pipe			PAW-FC4E-U020	PAW-FC4E-U030	PAW-FC4E-U040	—	PAW-FC4E-U060	PAW-FC4E-U070
Total cooling capacity <sup>1)</sup>	Med / Hi	kW	1,5/2,0	2,7/3,4	3,2/4,0	—	5,0/6,6	6,1/7,9
Sensible capacity <sup>1)</sup>	Med / Hi	kW	1,4/1,9	2,1/2,6	2,6/3,3	—	3,8/5,1	4,7/6,3
Water flow	Med / Hi	l/h	262/344	464/581	556/690	—	858/1144	1041/1366
Water pressure drop	Med / Hi	kPa	9,1/14,0	8,2/11,7	10,9/15,5	—	14,1/22,4	19,2/30,1
Heating capacity <sup>2)</sup>	Med / Hi	kW	0,9/1,2	3,1/3,8	3,5/4,1	—	5,5/7,0	7,1/9,8
Water flow	Med / Hi	l/h	153/201	530/658	603/699	—	939/1210	1214/1686
Water pressure drop	Med / Hi	kPa	33,4/53,6	24,2/35	30,9/39,8	—	13,8/20,7	20,8/36
Sound levels								
Global sound power level 2-pipe	Lo / Med / Hi	dB(A)	36/40/49	35/47/53	42/48/57	35/40/49	38/46/54	40/52/59
Global sound power level 4-pipe	Lo / Med / Hi	dB(A)	36/40/49	35/44/53	42/48/57	—	38/46/54	40/52/59
Global sound pressure level 2-pipe <sup>3)</sup>	Lo / Med / Hi	dB(A)	27/31/40	26/35/44	33/39/48	26/31/40	29/37/45	31/43/50
Global sound pressure level 4-pipe <sup>3)</sup>	Lo / Med / Hi	dB(A)	27/31/40	26/35/44	33/39/48	—	29/37/45	31/43/50
Fan								
Number	1							
Air flow	Med / Hi	m <sup>3</sup> /h	450/659	504/734	626/900	720/979	824/1159	1080/1598
Filter	G1							
Electrical data								
Power supply	Voltage	V	230	230	230	230	230	230
	Phase		Single Phase	Single Phase	Single Phase	Single Phase	Single Phase	Single Phase
	Frequency	Hz	50	50	50	50	50	50
Power consumption 2-pipe	Med / Hi	W	13/29	14/32	22/57	12/25	23/25	40/115
Power consumption 4-pipe	Med / Hi	W	13/29	14/32	22/57	—	23/46	40/115
Water connections								
Type			Female gas threaded	Female gas threaded	Female gas threaded	Female gas threaded	Female gas threaded	Female gas threaded
2-pipe		Inch	3/4	3/4	3/4	1	1	1
4-pipe	Cooling	Inch	3/4	3/4	3/4	—	1	1
	Heating	Inch	1/2	1/2	1/2	—	3/4	3/4
Dimensions and weight								
Dimensions including panel	H x W x D	mm	334 x 720 x 720	334 x 720 x 720	334 x 720 x 720	339 x 960 x 960	339 x 960 x 960	339 x 960 x 960
Weight		kg	14,8	16,5	16,5	37,1	37,1	39,6

1) According to Eurovent standard. Air: 27 °C DB / 19 °C WB. Water in/out: 7 °C/12 °C. 2) According to Eurovent standard. Air: 20 °C. Water in/out: 45 °C / 40 °C. 3) Information data considering a hypothetical sound attenuation of the room and installation of -9 dB(A).

### Technical focus

- 6 sizes\*
- Cooling capacity from 1,4 to 9,4 kW
- Heating capacity from 1,1 to 14,0 kW
- Low energy consumption EC fan

### Main features and accessories

- 2 and 4-pipe configurations
- Very low acoustic levels
- Quick access, by simply removing the front grille
- All connections: located at the same side
- Galvanized steel sheet with thermal and acoustical insulation, avoiding condensation on the casing and providing good sound attenuation
- Cleanable synthetic-type air filter

#### Operating limits

Entering water temperature	From 5 to 90 °C
Indoor air temperature	From 5 to 32 °C

\* 5 sizes available for 4-pipe configuration.





**PAW-FC-903TC**  
Optional Controller.  
Wired remote controller.



**PAW-FC-RC1**  
Optional Controller.  
Advanced wired remote controller.

**Fan coils - Ceiling chassis (AC)**

2-pipe	Left connection (PAW-)		FC2A-T010L	FC2A-T020L	FC2A-T030L	FC2A-T040L	FC2A-T050L	FC2A-T060L	FC2A-T070L	FC2A-T080L
	Right connection (PAW-)		FC2A-T010R	FC2A-T020R	FC2A-T030R	FC2A-T040R	FC2A-T050R	FC2A-T060R	FC2A-T070R	FC2A-T080R
Total cooling capacity <sup>1)</sup>	Med / S-Hi	kW	1,0/1,5	1,2/1,7	2,0/2,5	2,4/3,2	3,2/4,6	4,6/5,8	6,1/7,3	6,1/8,1
Sensible capacity <sup>1)</sup>	Med / S-Hi	kW	0,8/1,1	0,9/1,3	1,5/1,9	1,8/2,3	2,2/3,3	3,3/4,5	4,3/5,1	4,6/6,3
Water flow	Med / S-Hi	l/h	172/250	213/289	341/430	413/547	544/798	784/1003	1058/1252	1048/1400
Water pressure drop	Med / S-Hi	kPa	19,5/39,2	3,9/6,3	19,3/28,8	17,1/28,0	22,8/46,9	37,4/60,2	15,4/21,5	19,3/32,5
Heating capacity <sup>2)</sup>	Med / S-Hi	kW	1,4/2,0	1,5/2,2	2,4/3,1	2,9/4,0	4,1/5,7	5,3/7,1	7,9/9,3	8,1/11,6
4-pipe	Left connection (PAW-)		FC4A-T010L	FC4A-T020L	FC4A-T030L	FC4A-T040L	FC4A-T050L	FC4A-T060L	FC4A-T070L	FC4A-T080L
	Right connection (PAW-)		FC4A-T010R	FC4A-T020R	FC4A-T030R	FC4A-T040R	FC4A-T050R	FC4A-T060R	FC4A-T070R	FC4A-T080R
Total cooling capacity <sup>1)</sup>	Med / S-Hi	kW	0,9/1,3	1,1/1,6	1,9/2,4	2,3/3,0	3,0/4,3	4,4/5,6	5,9/6,9	5,9/8,0
Sensible capacity <sup>1)</sup>	Med / S-Hi	kW	0,7/1,0	0,8/1,2	1,5/1,8	1,7/2,2	2,2/3,1	3,2/4,3	4,2/4,9	4,4/6,2
Water flow	Med / S-Hi	l/h	159/225	192/268	327/414	388/517	522/748	756/967	1019/1193	1020/1380
Water pressure drop	Med / S-Hi	kPa	15,2/29,0	3,4/5,6	9,5/14,4	22,3/36,8	12,8/25,1	27,7/44,5	17,9/24,4	31,1/53,6
Heating capacity <sup>2)</sup>	Med / S-Hi	kW	0,7/1,0	0,9/1,1	1,4/1,6	1,6/2,1	2,3/2,6	2,9/3,3	3,6/4,0	5,6/6,1
Water flow	Med / S-Hi	l/h	127/178	146/190	232/274	273/354	401/443	505/560	626/682	963/1052
Water pressure drop	Med / S-Hi	kPa	3,5/5,6	3,2/5,3	9,0/11,9	26,5/42,7	24,6/29,5	43,9/52,9	117,9/137,8	63,7/75
Sound levels										
Global sound power level	S-Lo / Med / S-Hi	dB(A)	33/40/49	31/43/50	30/45/52	30/44/51	34/46/56	38/51/58	43/56/61	50/55/64
Global sound pressure level <sup>3)</sup>	S-Lo / Med / S-Hi	dB(A)	24/31/40	22/34/41	21/36/43	21/35/42	25/37/47	29/42/49	34/47/52	41/46/55
Fan										
Number			1	1	1	2	2	2	2	3
Air flow 2-pipe	Med / S-Hi	m <sup>3</sup> /h	190/283	179/265	274/390	357/499	486/716	640/933	893/1064	936/1397
Air flow 4-pipe	Med / S-Hi	m <sup>3</sup> /h	168/253	161/241	263/369	335/467	466/542	614/723	859/944	905/1042
Filter			G2	G2	G2	G2	G2	G2	G2	G2
Electrical data										
Power supply	Voltage	V	230	230	230	230	230	230	230	230
	Phase		Single Phase	Single Phase	Single Phase	Single Phase	Single Phase	Single Phase	Single Phase	Single Phase
	Frequency	Hz	50/60	50/60	50/60	50/60	50/60	50/60	50/60	50/60
Power consumption 2-pipe	Med / S-Hi	W	24/36	18/29	37/45	37/56	55/72	75/105	100/147	112/188
Power consumption 4-pipe	Med / S-Hi	W	24/36	18/28	37/44	37/55	54/70	74/104	99/145	112/188
Water connections										
Type			Female gas threaded	Female gas threaded	Female gas threaded	Female gas threaded	Female gas threaded	Female gas threaded	Female gas threaded	Female gas threaded
2-pipe		Inch	1/2	1/2	1/2	1/2	1/2	1/2	3/4	3/4
	Cooling	Inch	1/2	1/2	1/2	1/2	1/2	1/2	3/4	3/4
4-pipe		Inch	1/2	1/2	1/2	1/2	1/2	1/2	1/2	1/2
	Heating	Inch	1/2	1/2	1/2	1/2	1/2	1/2	1/2	1/2
Dimensions and weight										
Dimensions	H x W x D	mm	477 x 225 x 766	766 x 225 x 477	477 x 225 x 951	477 x 225 x 1136	477 x 225 x 1321	477 x 225 x 1506	575 x 225 x 1319	575 x 225 x 1506
Weight	2 / 4-pipes	kg	19/20	19/20	22/23	27/29	30/32	35/37	35/37	47/49

1) According to Eurovent standard. Air: 27 °C DB / 19 °C WB. Water in/ out: 7 °C / 12 °C. 2) Air: 20 °C. Water in/out: 50 °C / 45 °C. 3) The sound pressure levels are based on (NR) characteristics of a room having volume of 100 m<sup>3</sup> with reverberation of 0,5 seconds.

**Technical focus**

- Cooling capacity from 0,7 to 8,1 kW
- Heating capacity from 0,7 to 10,3 kW
- 5-speed AC fan motor(s)

**Main features and accessories**

- 2 and 4-pipe configurations
- Left or right hand arrangements
- Ease of installation
- Very low acoustic levels
- 2 way or 3 way ON/OFF valves
- Auxiliary drain pan
- Air intake with removable grid
- G2 filter

**Operating limits**

Entering water temperature	From 5 to 90 °C
Indoor air temperature	From 5 to 32 °C



ERP 2018: compliant following COMMISSION REGULATION (EU) No2016/2281.



PAW-FC-907TC  
Optional Controller.  
Wired remote  
controller for EC fans.

## Fan coils - Ceiling chassis (EC)

2-pipe	Left connection (PAW-)		FC2E-T010L	FC2E-T020L	FC2E-T030L	FC2E-T040L	FC2E-T050L	FC2E-T060L	FC2E-T070L	FC2E-T080L
	Right connection (PAW-)		FC2E-T010R	FC2E-T020R	FC2E-T030R	FC2E-T040R	FC2E-T050R	FC2E-T060R	FC2E-T070R	FC2E-T080R
Total cooling capacity <sup>1)</sup>	Med / S-Hi	kW	1,2/2,1	1,4/2,4	2,1/3,1	2,9/4,2	4,0/5,0	4,5/5,2	5,9/6,9	6,5/8,8
Sensible capacity <sup>1)</sup>	Med / S-Hi	kW	1,1/1,9	1,1/1,9	1,6/2,4	2,1/3,0	3,0/3,7	3,5/4,0	4,3/5,2	4,8/6,6
Water flow	Med / S-Hi	l/h	210/356	237/406	354/532	506/722	685/743	767/800	1008/1098	1111/1254
Water pressure drop	Med / S-Hi	kPa	28,2/76,9	4,6/11,0	20,5/42,1	24,4/46,3	35,1/41,0	35,8/38,8	14,0/16,6	21,4/26,6
Heating capacity <sup>2)</sup>	Med / S-Hi	kW	1,6/2,9	1,9/3,3	2,2/3,4	3,0/5,3	5,2/5,5	5,9/6,1	7,3/8,2	8,0/9,3
4-pipe	Left connection (PAW-)		FC4E-T010L	FC4E-T020L	FC4E-T030L	FC4E-T040L	FC4E-T050L	FC4E-T060L	FC4E-T070L	FC4E-T080L
	Right connection (PAW-)		FC4E-T010R	FC4E-T020R	FC4E-T030R	FC4E-T040R	FC4E-T050R	FC4E-T060R	FC4E-T070R	FC4E-T080R
Total cooling capacity <sup>1)</sup>	Med / S-Hi	kW	1,1/1,9	1,2/2,2	1,9/2,9	2,7/4,0	3,6/4,6	4,1/4,9	5,1/6,4	6,2/9,6
Sensible capacity <sup>1)</sup>	Med / S-Hi	kW	0,9/1,7	1,0/1,8	1,5/2,2	1,9/2,8	2,8/3,5	3,2/3,8	3,8/4,8	4,6/7,2
Water flow	Med / S-Hi	l/h	185/327	206/375	321/493	457/681	625/686	707/749	886/977	1070/1242
Water pressure drop	Med / S-Hi	kPa	20,1/59,2	3,7/9,7	9,2/19,7	29,6/60,1	17,9/21,3	24,3/27,2	13,6/16,5	33,9/44,3
Heating capacity <sup>2)</sup>	Med / S-Hi	kW	0,8/1,4	0,9/1,5	1,4/1,8	2,0/2,8	2,4/2,5	2,9/3,1	3,4/3,6	5,9/6,9
Water flow	Med / S-Hi	l/h	140/235	161/255	243/304	350/483	416/438	503/531	583/614	1011/1194
Water pressure drop	Med / S-Hi	kPa	4,0/8,4	3,8/9,4	9,7/14,1	41,8/76,3	26,3/28,9	43,6/48,1	103,8/113,9	69,7/95,1
<b>Sound levels</b>										
Global sound power level	S-Lo / Med / S-Hi	dB(A)	34/47/60	34/47/60	31/50/59	29/44/52	30/51/57	32/54/58	40/54/59	51/56/64
Global sound pressure level <sup>3)</sup>	S-Lo / Med / S-Hi	dB(A)	25/38/51	25/38/51	22/41/50	20/35/43	21/42/48	23/45/49	31/45/50	42/47/55
<b>Fan</b>										
Number			1	1	1	2	2	2	2	3
Air flow 2-pipe	Med / S-Hi	m <sup>3</sup> /h	228/417	234/413	380/585	412/678	645/702	737/779	850/950	927/1093
Air flow 4-pipe	Med / S-Hi	m <sup>3</sup> /h	199/379	200/380	342/540	369/627	587/646	668/716	798/894	884/1079
Filter			G2	G2	G2	G2	G2	G2	G2	G2
<b>Electrical data</b>										
Power supply	Voltage	V	230	230	230	230	230	230	230	230
	Phase		Single Phase	Single Phase	Single Phase	Single Phase	Single Phase	Single Phase	Single Phase	Single Phase
	Frequency	Hz	50/60	50/60	50/60	50/60	50/60	50/60	50/60	50/60
Power consumption 2-pipe	Med / S-Hi	W	11/41	13/41	16/42	13/43	24/46	30/54	44/77	42/108
Power consumption 4-pipe	Med / S-Hi	W	11/39	13/40	15/40	12/42	23/44	28/52	43/75	41/116
<b>Water connections</b>										
Type			Female gas threaded	Female gas threaded	Female gas threaded	Female gas threaded	Female gas threaded	Female gas threaded	Female gas threaded	Female gas threaded
2-pipe		Inch	1/2	1/2	1/2	1/2	1/2	1/2	3/4	3/4
4-pipe	Cooling	Inch	1/2	1/2	1/2	1/2	1/2	1/2	3/4	3/4
	Heating	Inch	1/2	1/2	1/2	1/2	1/2	1/2	1/2	1/2
<b>Dimensions and weight</b>										
Dimensions	H x W x D	mm	477 x 225 x 766	766 x 225 x 477	477 x 225 x 951	477 x 225 x 1136	477 x 225 x 1321	477 x 225 x 1506	575 x 225 x 1319	575 x 225 x 1506
Weight	2 / 4-pipes	kg	19/20	19/20	22/23	27/29	30/32	35/37	35/37	47/49

1) According to Eurovent standard. Air: 27 °C DB / 19 °C WB. Water in/ out: 7 °C / 12 °C. 2) Air: 20 °C. Water in/out: 50 °C / 45 °C. 3) The sound pressure levels are based on (NR) characteristics of a room having volume of 100 m<sup>3</sup> with reverberation of 0,5 seconds.

### Technical focus

- Cooling capacity from 0,5 to 9,6 kW
- Heating capacity from 0,6 to 13,6 kW
- Low energy consumption EC fan(s)

### Main features and accessories

- 2 and 4-pipe configurations
- Left or right hand arrangements
- Ease of installation
- Very low acoustic levels
- 2 way or 3 way ON/OFF valves
- Auxiliary drain pan
- Air intake with removable grid
- G2 filter

### Operating limits

Entering water temperature	From 5 to 90 °C
Indoor air temperature	From 5 to 32 °C



ERP 2018: compliant following COMMISSION REGULATION (EU) No2016/2281.



**PAW-FC-903TC**  
Optional Controller.  
Wired remote controller.



**PAW-FC-RC1**  
Optional Controller.  
Advanced wired remote controller.



**PAW-FC-RCFS**  
Optional Controller.  
Integrated controller for Floor Standing fan coil (AC).

**Fan coils - Floor Standing chassis (AC)**

2-pipe	Left connection (PAW-)		FC2A-P010L	FC2A-P020L	FC2A-P030L	FC2A-P040L	FC2A-P050L	FC2A-P060L	FC2A-P070L	FC2A-P080L
	Right connection (PAW-)		FC2A-P010R	FC2A-P020R	FC2A-P030R	FC2A-P040R	FC2A-P050R	FC2A-P060R	FC2A-P070R	FC2A-P080R
Total cooling capacity <sup>1)</sup>	Med / S-Hi	kW	1,0/1,5	1,2/1,7	2,0/2,5	2,4/3,2	3,2/4,6	4,6/5,8	6,1/7,3	6,1/8,1
Sensible capacity <sup>1)</sup>	Med / S-Hi	kW	0,8/1,1	0,9/1,3	1,5/1,9	1,8/2,3	2,2/3,3	3,3/4,5	4,3/5,1	4,6/6,3
Water flow	Med / S-Hi	l/h	172/250	213/289	341/430	413/547	544/798	784/1003	1058/1252	1048/1400
Water pressure drop	Med / S-Hi	kPa	19,5/39,2	3,9/6,3	19,3/28,8	17,1/28,0	22,8/46,9	37,4/60,2	15,4/21,5	19,3/32,5
Heating capacity <sup>2)</sup>	Med / S-Hi	kW	1,4/2,0	1,5/2,2	2,4/3,1	2,9/4,0	4,1/5,7	5,3/7,1	7,9/9,3	8,1/11,6
4-pipe	Left connection (PAW-)		FC4A-P010L	FC4A-P020L	FC4A-P030L	FC4A-P040L	FC4A-P050L	FC4A-P060L	FC4A-P070L	FC4A-P080L
	Right connection (PAW-)		FC4A-P010R	FC4A-P020R	FC4A-P030R	FC4A-P040R	FC4A-P050R	FC4A-P060R	FC4A-P070R	FC4A-P080R
Total cooling capacity <sup>1)</sup>	Med / S-Hi	kW	0,9/1,3	1,1/1,6	1,9/2,4	2,3/3,0	3,0/4,3	4,4/5,6	5,9/6,9	5,9/8,0
Sensible capacity <sup>1)</sup>	Med / S-Hi	kW	0,7/1,0	0,8/1,2	1,5/1,8	1,7/2,2	2,2/3,1	3,2/4,3	4,2/4,9	4,4/6,2
Water flow	Med / S-Hi	l/h	159/225	192/268	327/414	388/517	522/748	756/967	1019/1193	1020/1380
Water pressure drop	Med / S-Hi	kPa	15,2/29,0	3,4/5,6	9,5/14,4	22,3/36,8	12,8/25,1	27,7/44,5	17,9/24,4	31,1/53,6
Heating capacity <sup>2)</sup>	Med / S-Hi	kW	0,7/1,0	0,9/1,1	1,4/1,6	1,6/2,1	2,3/2,6	2,9/3,3	3,6/4,0	5,6/6,1
Water flow	Med / S-Hi	l/h	127/178	146/190	232/274	273/354	401/443	505/560	626/682	963/1052
Water pressure drop	Med / S-Hi	kPa	3,5/5,6	3,2/5,3	9,0/11,9	26,5/42,7	24,6/29,5	43,9/52,9	117,9/137,8	63,7/75
Sound levels										
Global sound power level	S-Lo / Med / S-Hi	dB(A)	33/40/49	31/43/50	30/45/52	30/44/51	34/46/56	38/51/58	43/56/61	50/55/64
Global sound pressure level <sup>3)</sup>	S-Lo / Med / S-Hi	dB(A)	24/31/40	22/34/41	21/36/43	21/35/42	25/37/47	29/42/49	34/47/52	41/46/55
Fan										
Number			1	1	1	2	2	2	2	3
Air flow 2-pipe	Med / S-Hi	m <sup>3</sup> /h	190/283	179/265	274/390	357/499	486/716	640/933	893/1064	936/1397
Air flow 4-pipe	Med / S-Hi	m <sup>3</sup> /h	168/253	161/241	263/369	335/467	466/542	614/723	859/944	905/1042
Filter			G2	G2	G2	G2	G2	G2	G2	G2
Electrical data										
Power supply	Voltage	V	230	230	230	230	230	230	230	230
	Phase		Single Phase	Single Phase	Single Phase	Single Phase	Single Phase	Single Phase	Single Phase	Single Phase
	Frequency	Hz	50/60	50/60	50/60	50/60	50/60	50/60	50/60	50/60
Power consumption 2-pipe	Med / S-Hi	W	24/36	18/29	37/45	37/56	55/72	75/105	100/147	112/188
Power consumption 4-pipe	Med / S-Hi	W	24/36	18/28	37/44	37/55	54/70	74/104	99/145	112/188
Water connections										
Type			Female gas threaded	Female gas threaded	Female gas threaded	Female gas threaded	Female gas threaded	Female gas threaded	Female gas threaded	Female gas threaded
2-pipe		Inch	1/2	1/2	1/2	1/2	1/2	1/2	3/4	3/4
	Cooling	Inch	1/2	1/2	1/2	1/2	1/2	1/2	3/4	3/4
4-pipe		Inch	1/2	1/2	1/2	1/2	1/2	1/2	1/2	1/2
	Heating	Inch	1/2	1/2	1/2	1/2	1/2	1/2	1/2	1/2
Dimensions and weight										
Dimensions	H x W x D	mm	477 x 225 x 766	766 x 225 x 477	477 x 225 x 951	477 x 225 x 1136	477 x 225 x 1321	477 x 225 x 1506	575 x 225 x 1319	575 x 225 x 1506
Weight	2 / 4-pipes	kg	19/20	19/20	22/23	27/29	30/32	35/37	35/37	47/49

1) According to Eurovent standard. Air: 27 °C DB / 19 °C WB. Water in/ out: 7 °C / 12 °C. 2) Air: 20 °C. Water in/out: 50 °C / 45 °C. 3) The sound pressure levels are based on (NR) characteristics of a room having volume of 100 m<sup>3</sup> with reverberation of 0,5 seconds.

**Technical focus**

- Cooling capacity from 0,7 to 8,1 kW
- Heating capacity from 0,7 to 10,3 kW
- 5-speed AC fan motor(s)

**Main features and accessories**

- 2 and 4-pipe configurations
- Left or right hand arrangements
- Ease of installation
- Very low acoustic levels
- 2 way or 3 way ON/OFF valves
- Auxiliary drain pan
- Air intake with removable grid
- G2 filter
- PAW-FSF feet for floor standing units



ERP 2018: compliant following COMMISSION REGULATION (EU) No2016/2281.

Operating limits	
Entering water temperature	From 5 to 90 °C
Indoor air temperature	From 5 to 32 °C





**PAW-FC-907TC**  
Optional Controller.  
Wired remote  
controller for EC fans.

## Fan coils - Floor Standing chassis (EC)

2-pipe	Left connection (PAW-)		FC2E-P010L	FC2E-P020L	FC2E-P030L	FC2E-P040L	FC2E-P050L	FC2E-P060L	FC2E-P070L	FC2E-P080L
	Right connection (PAW-)		FC2E-P010R	FC2E-P020R	FC2E-P030R	FC2E-P040R	FC2E-P050R	FC2E-P060R	FC2E-P070R	FC2E-P080R
Total cooling capacity <sup>1)</sup>	Med / S-Hi	kW	1,2/2,1	1,4/2,4	2,1/3,1	2,9/4,2	4,0/5,0	4,5/5,2	5,9/6,9	6,5/8,8
Sensible capacity <sup>1)</sup>	Med / S-Hi	kW	1,1/1,9	1,1/1,9	1,6/2,4	2,1/3,0	3,0/3,7	3,5/4,0	4,3/5,2	4,8/6,6
Water flow	Med / S-Hi	l/h	210/356	237/406	354/532	506/722	685/743	767/800	1008/1098	1111/1254
Water pressure drop	Med / S-Hi	kPa	28,2/76,9	4,6/11,0	20,5/42,1	24,4/46,3	35,1/41,0	35,8/38,8	14,0/16,6	21,4/26,6
Heating capacity <sup>2)</sup>	Med / S-Hi	kW	1,6/2,9	1,9/3,3	2,2/3,4	3,0/5,3	5,2/5,5	5,9/6,1	7,3/8,2	8,0/9,3
4-pipe	Left connection (PAW-)		FC4E-P010L	FC4E-P020L	FC4E-P030L	FC4E-P040L	FC4E-P050L	FC4E-P060L	FC4E-P070L	FC4E-P080L
	Right connection (PAW-)		FC4E-P010R	FC4E-P020R	FC4E-P030R	FC4E-P040R	FC4E-P050R	FC4E-P060R	FC4E-P070R	FC4E-P080R
Total cooling capacity <sup>1)</sup>	Med / S-Hi	kW	1,1/1,9	1,2/2,2	1,9/2,9	2,7/4,0	3,6/4,6	4,1/4,9	5,1/6,4	6,2/9,6
Sensible capacity <sup>1)</sup>	Med / S-Hi	kW	0,9/1,7	1,0/1,8	1,5/2,2	1,9/2,8	2,8/3,5	3,2/3,8	3,8/4,8	4,6/7,2
Water flow	Med / S-Hi	l/h	185/327	206/375	321/493	457/681	625/686	707/749	886/977	1070/1242
Water pressure drop	Med / S-Hi	kPa	20,1/59,2	3,7/9,7	9,2/19,7	29,6/60,1	17,9/21,3	24,3/27,2	13,6/16,5	33,9/44,3
Heating capacity <sup>2)</sup>	Med / S-Hi	kW	0,8/1,4	0,9/1,5	1,4/1,8	2,0/2,8	2,4/2,5	2,9/3,1	3,4/3,6	5,9/6,9
Water flow	Med / S-Hi	l/h	140/235	161/255	243/304	350/483	416/438	503/531	583/614	1011/1194
Water pressure drop	Med / S-Hi	kPa	4,0/8,4	3,8/9,4	9,7/14,1	41,8/76,3	26,3/28,9	43,6/48,1	103,8/113,9	69,7/95,1
<b>Sound levels</b>										
Global sound power level	S-Lo / Med / S-Hi	dB(A)	34/47/60	34/47/60	31/50/59	29/44/52	30/51/57	32/54/58	40/54/59	51/56/64
Global sound pressure level <sup>3)</sup>	S-Lo / Med / S-Hi	dB(A)	25/38/51	25/38/51	22/41/50	20/35/43	21/42/48	23/45/49	31/45/50	42/47/55
<b>Fan</b>										
Number			1	1	1	2	2	2	2	3
Air flow 2-pipe	Med / S-Hi	m <sup>3</sup> /h	228/417	234/413	380/585	412/678	645/702	737/779	850/950	927/1093
Air flow 4-pipe	Med / S-Hi	m <sup>3</sup> /h	199/379	200/380	342/540	369/627	587/646	668/716	798/894	884/1079
Filter			G2	G2	G2	G2	G2	G2	G2	G2
<b>Electrical data</b>										
Power supply	Voltage	V	230	230	230	230	230	230	230	230
	Phase		Single Phase	Single Phase	Single Phase	Single Phase	Single Phase	Single Phase	Single Phase	Single Phase
	Frequency	Hz	50/60	50/60	50/60	50/60	50/60	50/60	50/60	50/60
Power consumption 2-pipe	Med / S-Hi	W	11/41	13/41	16/42	13/43	24/46	30/54	44/77	42/108
Power consumption 4-pipe	Med / S-Hi	W	11/39	13/40	15/40	12/42	23/44	28/52	43/75	41/116
<b>Water connections</b>										
Type			Female gas threaded	Female gas threaded	Female gas threaded	Female gas threaded	Female gas threaded	Female gas threaded	Female gas threaded	Female gas threaded
2-pipe		Inch	1/2	1/2	1/2	1/2	1/2	1/2	3/4	3/4
	Cooling	Inch	1/2	1/2	1/2	1/2	1/2	1/2	3/4	3/4
4-pipe		Inch	1/2	1/2	1/2	1/2	1/2	1/2	1/2	1/2
	Heating	Inch	1/2	1/2	1/2	1/2	1/2	1/2	1/2	1/2
<b>Dimensions and weight</b>										
Dimensions	H x W x D	mm	477 x 225 x 766	766 x 225 x 477	477 x 225 x 951	477 x 225 x 1136	477 x 225 x 1321	477 x 225 x 1506	575 x 225 x 1319	575 x 225 x 1506
Weight	2 / 4-pipes	kg	19/20	19/20	22/23	27/29	30/32	35/37	35/37	47/49

1) According to Eurovent standard. Air: 27 °C DB / 19 °C WB. Water in/ out: 7 °C / 12 °C. 2) Air: 20 °C. Water in/out: 50 °C / 45 °C. 3) The sound pressure levels are based on (NR) characteristics of a room having volume of 100 m<sup>3</sup> with reverberation of 0,5 seconds.

### Technical focus

- Cooling capacity from 0,5 to 9,6 kW
- Heating capacity from 0,6 to 13,6 kW
- Low energy consumption EC fan(s)

### Main features and accessories

- 2 and 4-pipe configurations
- Left or right hand arrangements
- Ease of installation
- Very low acoustic levels
- 2 way or 3 way ON/OFF valves
- Auxiliary drain pan
- Air intake with removable grid
- G2 filter
- PAW-FSF feet for floor standing units

### Operating limits

Entering water temperature	From 5 to 90 °C
Indoor air temperature	From 5 to 32 °C



ERP 2018: compliant following COMMISSION REGULATION (EU) No2016/2281.



PAW-FC-903TC  
Optional Controller.  
Wired remote  
controller.



PAW-FC-RC1  
Optional Controller.  
Advanced wired  
remote controller.



IR Controller  
Infrared remote  
supplied with IR  
versions.

## Fan coils - Wall Mounted (AC)

2-pipe			PAW-FC2A-K007	PAW-FC2A-K009	PAW-FC2A-K018	PAW-FC2A-K022
			PAW-FC2A-K007IR	PAW-FC2A-K009IR	PAW-FC2A-K018IR	PAW-FC2A-K022IR
Total cooling capacity <sup>1)</sup>	Med / Hi	kW	1,3/1,7	1,7/2,4	3,0/3,5	3,1/3,9
Sensible capacity <sup>1)</sup>	Med / Hi	kW	1,0/1,2	1,3/1,9	2,3/2,7	2,5/3,1
Water flow	Med / Hi	l/h	231/287	291/418	508/609	535/669
Water pressure drop	Med / Hi	kPa	24,9/30,9	27,0/40,0	41,3/55,6	33,7/45,2
Heating capacity <sup>2)</sup>	Med / Hi	kW	1,7/2,0	2,0/2,7	3,2/4,0	3,7/4,4
<b>Sound levels</b>						
Sound power level	Lo / Med / Hi	dB(A)	45/49/51	47/52/57	49/53/56	53/57/63
Sound pressure level <sup>3)</sup>	Lo / Med / Hi	dB(A)	30/33/35	32/36/40	39/41/43	39/43/48
<b>Fan</b>						
Number			1	1	1	1
Air flow	Med / Hi	m <sup>3</sup> /h	321/360	413/551	592/680	709/850
Filter			G1	G1	G1	G1
<b>Electrical data</b>						
Power supply	Voltage	V	230	230	230	230
	Phase		Single Phase	Single Phase	Single Phase	Single Phase
	Frequency	Hz	50	50	50	50
Fuse Rating		A	3	3	3	3
Power consumption	Med / Hi	W	42/62	47/59	50/55	55/70
<b>Water connections</b>						
Type			Female gas threaded	Female gas threaded	Female gas threaded	Female gas threaded
Connections		Inch	1/2	1/2	1/2	1/2
<b>Dimensions and weight</b>						
Dimensions	H x W x D	mm	275 x 180 x 845	275 x 180 x 845	298 x 200 x 940	298 x 200 x 940
Weight		kg	11	11	13	13

1) According to Eurovent standard. Air: 27 °C DB / 19 °C WB. Water in/out: 7 °C / 12 °C. 2) According to Eurovent standard. Air: 20 °C. Water in/out: 45 °C / 40 °C. 3) Sound pressure considering a local of 100 m<sup>3</sup> a reverberation time of 0,5 seconds and a distance of 1 m.

### Technical focus

- 4 sizes
- Cooling capacity from 1,0 to 3,9 kW
- Heating capacity from 1,4 to 4,1 kW
- Version: 2-pipes, AC fan

### Main features and accessories

- 2 way or 3 way valve ON/OFF
- 3-speed AC fan motor
- Silent unit for optimum customer comfort
- Aesthetic design suitable for residential and hotel applications
- Compatible with IR controller (supplied with IR versions)
- Coil with hydrophilic fins to improve the condensate flow

### Operating limits

Entering water temperature	From 5 to 60 °C
Indoor air temperature	From 6 to 40 °C



ERP 2018: compliant following COMMISSION REGULATION (EU) No2016/2281.

# Fan coil valve accessories

## General information

- Variety of optional valve configuration
- Suitable for 2-pipe and 4-pipe fan coil units
- 2-way and 3-way valve arrangements

Fan coil type	Fan coil pipe configuration	Model Reference	Description	Model compatibility
Ceiling, Floor Standing and Ducted	2-pipe	PAW-FC-2WY-11/55-1	2 way valve + drain pan	2-pipe Ceiling, Floor Standing and Ducted models D11-D55 and 010-060
		PAW-FC-2WY-65/90-1		2-pipe Ceiling, Floor Standing and Ducted models D65-D90 and 070-080
		PAW-FC-2WY-F040		2-pipe Ducted model F040
		PAW-FC-3WY-11/55-1	3 way valve + drain pan	2-pipe Ceiling, Floor Standing and Ducted models D11-D55 and 010-060
		PAW-FC-3WY-65/90-1		2-pipe Ceiling, Floor Standing and Ducted models D65-D90 and 070-080
		PAW-FC-3WY-F040		2-pipe Ducted model F040
	4-pipe	PAW-FC4-2WY-010	2 way valve + drain pan	4-pipe Ceiling, Floor Standing and Ducted models 010-060
		PAW-FC4-2WY-070		4-pipe Ceiling, Floor Standing and Ducted models 070-080
		PAW-FC4-2WY-F040		4-pipe Ducted model F040
		PAW-FC4-3WY-010	3 way valve + drain pan	4-pipe Ducted, Ceiling and floor standing model 010
		PAW-FC4-3WY-020		4-pipe Ceiling, Floor Standing and Ducted models 020-060
		PAW-FC4-3WY-070		4-pipe Ceiling, Floor Standing and Ducted models 070-080
PAW-FC4-3WY-F040	4-pipe Ducted model F040			
High Static Ducted	2-pipe	PAW-FC2-2WY-E070	2 way valve + drain pan	2-pipe High Static Ducted models E070
		PAW-FC-2WY-150		2-pipe High Static Ducted models E150-E180
		PAW-FC2-2WY-E210		2-pipe High Static Ducted models E210-E240
		PAW-FC2-3WY-E070	3 way valve + drain pan	2-pipe High Static Ducted models E070
		PAW-FC-3WY-150		2-pipe High Static Ducted models E150-E180
		PAW-FC2-3WY-E210		2-pipe High Static Ducted models E210-E240
	4-pipe	PAW-FC4-2WY-E070	2 way valve + drain pan	4-pipe High Static Ducted model E070
		PAW-FC4-2WY-E150		4-pipe High Static Ducted models E150-E180
		PAW-FC4-3WY-E210		4-pipe High Static Ducted models E210-E240
		PAW-FC4-3WY-E070	3 way valve + drain pan	4-pipe High Static Ducted model E070
		PAW-FC4-3WY-E150		4-pipe High Static Ducted models E150-E180
		PAW-FC4-3WY-E210		4-pipe High Static Ducted models E210-E240
Cassette	2-pipe	PAW-FC2-2WY-U020	2 way valve + drain pan	2-pipe Cassette models U020-U040
		PAW-FC2-2WY-U050		2-pipe Cassette models U050-U070
		PAW-FC2-3WY-U020	3 way valve + drain pan	2-pipe Cassette models U020-040
		PAW-FC2-3WY-U050		2-pipe Cassette models U050-070
	4-pipe	PAW-FC4-2WY-U020	2 way valve + drain pan	3-pipe Cassette models U020-U040
		PAW-FC4-2WY-U050		3-pipe Cassette models U050-U070
		PAW-FC4-3WY-U020	3 way valve + drain pan	3-pipe Cassette models U020-U040
		PAW-FC4-3WY-U050		3-pipe Cassette models U050-U070
Wall Mounted	2-pipe	PAW-FC2-2WY-K007	2 way valve + drain pan	2-pipe Wall Mounted K007-K022
		PAW-FC2-3WY-K007	3 way valve + drain pan	2-pipe Wall Mounted K007-K022



## Panasonic condensing units with natural refrigerant

Panasonic's CR Series of CO<sub>2</sub> condensing units provide the ideal solution for supermarkets, convenience stores and gas stations.

Keeping food always fresh at right temperature in showcases or cold rooms is a very critical point. And one of the biggest challenges for those retailers has been the expensive effects of refrigeration breakdowns which can result in costly product wastage.

## Natural refrigerant CO<sub>2</sub>.

CO<sub>2</sub> is a very attractive refrigerant from an environmental perspective.

Zero ODP and "GWP" (Global Warming Potential)=1 means natural substance in the atmosphere.

Panasonic is now able to provide a solution in Europe with CO<sub>2</sub> refrigeration systems to prevent global warming and to support environment-friendly retail operations.



## CO<sub>2</sub> Condensing units CR Series by trusted technology.

CR Series are made in Japan with an excellent quality control established by skilled factory team. CO<sub>2</sub> 2-stage compression rotary compressor by Panasonic is designed to compress refrigerants twice, it reduces load in operation by half compared with 1-stage refrigerant compression and delivers better durability and reliability.

## New line-up 7,5 kW MT Type.

Medium temperature operation (evaporation temperature set point range -20 ~ -5 °C). Maximum cooling capacity: 7,4 kW\* (ET -10 °C AT 32°). Slim & light unit with 1 fan. Heat Recovery port available.

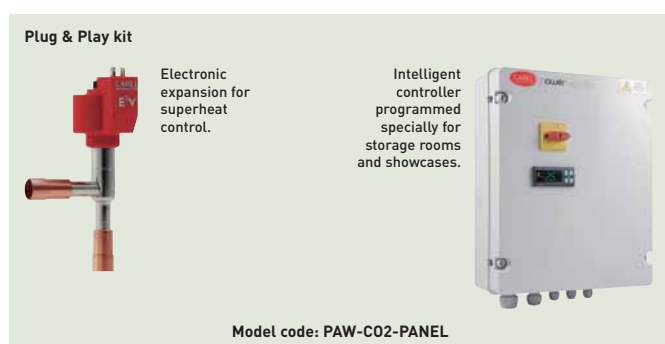

## Save installation time with Plug & Play kit.

To ensure a quick and easy install of the product, Panasonic has designed a one box solution that includes the condensing unit, a panel pre-programmed controller, electronic expansion and all required sensors in addition to providing easy to understand instructions.

## Modbus compatibility with monitoring system.

Panasonic CO<sub>2</sub> condensing units can be supervised by major monitoring system such as CAREL, Eliwell and Danfoss. Monitoring system ensures the recording, monitoring and reporting of temperature conditions etc. of entire CO<sub>2</sub> condensing units system at shops.

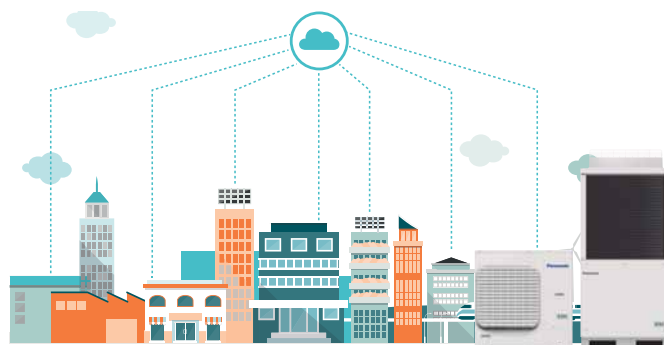

# Choose the green solution by Panasonic

## Why CO<sub>2</sub>?: Natural refrigerant

EU F-Gas Regulation is a key priority for European countries. It ensures compliance with the Kigali Amendment supporting international climate commitments on greenhouse gases and leading the global transition to climate-friendly HFC-free technologies. Carbon dioxide (R-744) is regaining its place in the refrigeration world. Driven by environmental concerns, legislation is requiring increased adoption of 'alternative' refrigerants, of which CO<sub>2</sub> is one.

The following table shows how well R744 (CO<sub>2</sub>) performs regarding environmental impact and safety.

ODP (Ozone Depletion Potential) = 0 - GWP (Global Warming Potential) = 1					
	Next generation refrigerant			Current refrigerant	
	CO <sub>2</sub>	Ammonia	Isobutane	R410A	R404A
ODP	0	0	0	0	0
GWP	1	0	4	2090	3920
Flammability	Non flammable	Light flammable	Flammable	Non flammable	Non flammable
Toxicity	No	Yes	No	No	No

## CO<sub>2</sub> transcritical condensing units CR Series

- Set-points at medium or low temperature available depending on applications
- High COP at high ambient temperature thanks to Panasonic's 2-stage compression CO<sub>2</sub> rotary compressor
- Compact and extremely quiet
- Transfer pressure control for stable expansion valve control in showcases (1000VF8 and 1000VF8A models only)

\* SEPR values has been tested at 3-part laboratory.

CR Series	Low temperature	Medium temperature	ET (Evaporation Temperature) Set points range
OCU-CR200VF5	✓	✓	-45 ~ -5 °C
OCU-CR400VF8	—	✓	-20 ~ -5 °C
OCU-CR1000VF8	—	✓	-20 ~ -5 °C
OCU-CR1000VF8A	✓	✓	-45 ~ -5 °C

MT/LT TYPE  
200VF5  
4 kW / 2 kW

MT TYPE  
400VF8  
7,5 kW



MT TYPE  
1000VF8 - 15 kW

MT/LT TYPE  
1000VF8A  
16 kW / 8 kW

**3,83**  
SEPR COOLING\*

**1,92**  
SEPR FREEZING\*

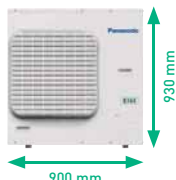
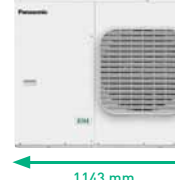
NEW  
2020

## 16 kW MT/LT Type (1000VF8A)

### Both MT and LT options.

Maximum cooling capacity.

MT: Up to 16 kW.

LT: Up to 8 kW.

### Flexible installation.

- Maximum piping length: 100 m
  - High external static pressure: 58Pa
  - Up scales tank 12L
- This 12L tank keeps inside extra amount of refrigerant when the system stops.
- Also helping installers by making wider tolerance from optimum charge.

## Saving installation time with Plug & Play kit

To ensure a quick and easy install of the product, Panasonic has designed a one box solution that includes the condensing unit, a panel pre-programmed controller, electronic expansion and all required sensors in addition to providing easy to understand instructions.

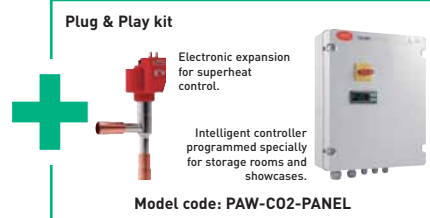
**Plug & Play kit**

- Electronic expansion for superheat control.
- Intelligent controller programmed specially for storage rooms and showcases.

**Model code: PAW-CO2-PANEL**

## Modbus compatible with monitoring system

Panasonic CO<sub>2</sub> condensing unit CR Series can be supervised by major monitoring system such as CAREL, Eliwell and Danfoss. Monitoring system ensures the recording, monitoring and reporting of temperature conditions etc... of entire CO<sub>2</sub> condensing units system at shops.

### Monitoring system

 Standard boss & boss-mini	 AK-SM Series	 TelevisGo
--	---	--



Type (MT: medium temp. LT: low temp.)		MT (4 kW) / LT (2 kW)		NEW MT (7,5 kW)		MT (15 kW)		MT(16 kW) / LT (8 kW)						
Standard model		OCU-CR200VF5		OCU-CR400VF8		OCU-CR1000VF8		OCU-CR1000VF8A						
Anti corrosion coating model		OCU-CR200VF5SL		OCU-CR400VF8SL		OCU-CR1000VF8SL		OCU-CR1000VF8ASL						
Power supply	Voltage	V	220/230/240		380/400/415		380/400/415		380/400/415					
	Phase		Single Phase		Three Phase		Three Phase		Three Phase					
	Frequency	Hz	50		50		50		50					
Cooling capacity at ET -10 °C AT 32 °C		kW	3,70		6,90		14,00		15,10					
Cooling capacity at ET -35 °C AT 32 °C		kW	1,80		—		—		8,00					
Evaporator connection			Multiple <sup>1)</sup>		Multiple <sup>1)</sup>		Multiple		Multiple					
Evaporation temperature	Min ~ Max	°C	-45 ~ -5		-20 ~ -5		-20 ~ -5		-45 ~ -5					
	Ambient temperature	Min ~ Max	-15 ~ +43		-15 ~ +43		-15 ~ +43		-15 ~ +43					
Refrigerant			R744		R744		R744		R744					
Design pressure liquid line		Mpa	12		8		8		8					
Design pressure suction line		Mpa	8		8		8		8					
User system external alarm. Digital input. Non-voltage contact			Yes		Yes		Yes		Yes					
Liquid tube electromagnetic valve		Vac	220/230/240		380/400/415		220/230/240		220/230/240					
Showcase operation ON/OFF signal. Digital input. Non-voltage contact			Yes		Yes		Yes		Yes					
Modbus communication line (RS485)		Ports	2		2		2		2					
Compressor type			2- stage rotary		2- stage rotary		2- stage rotary		2- stage rotary					
Dimension		H x W x D	930x900x437		948x1143x609		1941x890x890		1941x890x890					
Net weight		Kg	70		TBC		293		320					
Piping connections	Suction pipe	Inch (mm)	3/8(9,52)		1/2(12,70)		3/4(19,05)		3/4(19,05)					
	Liquid pipe	Inch (mm)	1/4(6,35)		3/8(9,52)		5/8(15,88)		5/8(15,88)					
Length of connection piping		m	25		TBC		100 <sup>2)</sup>		100 <sup>2)</sup>					
Ambient temperature		°C	32		32		32		32					
Evaporating temperature		°C	-10	-35	-10	-35	-10	-10	-10	-35	-10	-35		
Standard performance	Cooling capacity	kW	3,70	1,80	3,70	1,80	6,90	6,90	14,00	14,00	15,10	8,00	15,10	8,00
	Power consumption	kW	1,79	1,65	1,79	1,65	TBC	TBC	8,20	8,20	8,20	7,57	8,20	7,57
	Nominal load ampere	A	7,94	7,26	7,94	7,26	TBC	TBC	12,60	12,60	12,60	11,60	12,60	11,60
	Sound pressure level	dB(A)	35,5 <sup>3)</sup>	35,5 <sup>3)</sup>	35,5 <sup>3)</sup>	35,5 <sup>3)</sup>	TBC	TBC	36,0 <sup>4)</sup>	36,0 <sup>4)</sup>	36,0 <sup>4)</sup>	36,0 <sup>4)</sup>	36,0 <sup>4)</sup>	36,0 <sup>4)</sup>
PED			I		II		II		II					
Air volume		m <sup>3</sup> /min	54		TBC		220		220					
External static pressure		Pa	17		TBC		58		58					
Heat recovery port			—		Yes		—		Yes					
Drier filter liquid line, diameter 6,35 mm			Included		TBC		—		—					
Drier filter liquid line, diameter 15,88 mm			—		TBC		Included		Included					
<b>Necessary accessories</b>														
Tube connector adaptor for vacuum and service		SPK-TU125	Yes (must be ordered)			TBC		Yes (must be ordered)		Yes (must be ordered)				
Suction filter, diameter 19,05 mm (outer diameter welding)		S-008T	—			TBC		Yes (must be ordered)		Yes (included: delivered with the unit)				

Accessories	
PAW-C02-PANEL	Room and superheat control including both panel + expansion valve
SPK-TU125	Tube connector adaptor for vacuum and service

Accessories	
S-008T	Suction filter
PZ-68S (Spare part) <sup>5)</sup>	Refrigeration oil

1) Ask salesperson if you make multiple connection. 2) PZ-68S (refrigeration oil) must be added if >50 m. 3) ET-10 °C, 65 S-1, 10 m from product. 4) ET -10 °C, 60 S-1, 10 m from product. 5) Please consult with authorized Panasonic dealers.

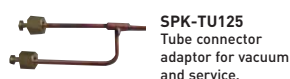

## Energy saving



Refrigerant gas R32 Our heat pumps containing the refrigerant R32 show a drastic reduction in the value of Global Warming Potential (GWP).



Better efficiency and Value for medium temperature applications. Energy efficiency class up to A++ in a scale from A+++ to D.



Better efficiency and Value for low temperature applications. Energy efficiency class up to A+++ in a scale from A+++ to D.



Better efficiency and Value for domestic hot water. Energy efficiency class up to A+ in a scale from A+ to F.



Aquarea are built-in with A class energy efficiency water pump. High efficiency circulating the water in the heating installation.



Exceptional Seasonal Cooling Efficiency based on the new ErP regulation. Higher SEER ratings mean greater efficiency - year-round cooling savings!



Exceptional Seasonal Heating Efficiency based on the new ErP regulation. Higher SCOP ratings mean greater efficiency - year-round heating savings!



Domestic Econavi. Sunlight Sensor technology can detect and reduce the waste of energy by optimising air conditioner operation according to room conditions. With just one touch of a button, you can save energy.



Commercial Econavi. Intelligent Human Activity Sensor and new Sunlight Sensor technologies that can detect and reduces the waste of energy by optimising air conditioner operation according to room conditions. With just one touch of a button, you can save energy.



Inverter Plus System classification highlights Panasonic's highest performing systems.



Inverter. The Inverter range provides greater efficiency and comfort. Provides more precise temperature control, without highs and lows, and keeps the ambient temperature constant with lower energy consumption and a significant reduction in noise and vibration levels.



Panasonic R2 Rotary Compressor. Designed to withstand extreme conditions, it delivers high performance and efficiency.



High efficiency compressor. Compressors that operate with a wider Hz range realize a more efficient operation throughout the year. For Big PACi Series.



All inverter compressors. Multiple large-capacity all inverter compressors (more than 14 HP). Two independently controlled inverter compressors achieve high efficiency. Redesigned components in the body provide performance improvement especially in the rated cooling condition and EER performance.



High efficiency models performs higher COP than standard units and standard combinations.



High seasonal efficiency in cooling mode. SEER follows COMMISSION REGULATION (EU) No 2016/2281.



High seasonal efficiency in heating mode. SCOP follows COMMISSION REGULATION (EU) No 813/2013.



ECOi-W Series are compliant with ErP regulation. SEER follows COMMISSION REGULATION (EU) No 2016/2281. SCOP follows COMMISSION REGULATION (EU) No 813/2013.



EC motor green ventilation. Range of fan coil with improved efficiency with optional EC fan motor.

## High performance and air



Aquarea High Performance for low consumption houses. From 3 to 16 kW. For a house with low temperature radiators or under-floor heating, our high performance Aquarea HP is a good solution. \*COP of 5,33 for J Generation 3 kW.



Aquarea T-CAP for extremely low temperatures. From 9 to 16 kW. If the most important aspect is to maintain nominal heating capacities even at temperatures as low as -7 °C or -20 °C, select the Aquarea T-CAP.



Aquarea HT ideal for retrofit. From 9 to 12 kW. For a house with traditional high-temperature radiators, the Aquarea HT solution is the most appropriate, can work in output water temperatures of 65 °C even at outdoor temperatures as low as -20 °C.



DHW. With Aquarea you can also heat your domestic hot water at a very low cost with the optional hot water cylinder.



Water filter with magnet. Easy access & fast clip technology for J Generation. Water filter only for H Generation.



60 °C output water. Reaches water outlet temperature up to 60 °C.



45 °C Output water. Maximum water outlet temperature up to 45 °C.



Water Flow Sensor. Included on J and H Generation.



nanoe™ X. Quality air for life. Panasonic's latest innovation nanoe™ X promotes well-being by inhibiting growth of certain harmful viruses and bacteria, as well as deodorising your home.



PM2,5 filter. Particulate matter (PM2,5) can be found suspended in the air, including dust, dirt, smoke and liquid droplets. This filter can catch PM2,5 particles including hazardous pollutants as well as house dust and pollen.



Dust Collection Filter. This filter collects and retains particles suspended in the air, resulting in cleaner air in the room.



Super Quiet. With Super Quiet technology our devices are quieter than a library (30 dB(A)).



Super quiet. Extra quiet operation is available as standard (with sizes 20 - 40, 140 - 210).



Fine control helps prevent a rapid decrease in room humidity while maintaining the set temperature. Maintains an RH\* up to 10 % higher than cooling operation (\*RH: Relative Humidity). Ideal when sleeping with the air conditioner on.



Mild Dry. By intermittent control of compressor and indoor unit's fan, "Mild Dry" gives you comfort. It realizes efficient dehumidification according to room temperature.



More comfort with Aerowings. Direct air flow to the ceiling, creating a shower cooling effect with built-in twin flap.



Static pressure up to 7 mmAq. Low static pressure Hide Away RAC with selectable static pressure up to 7 mmAq.



Filter included. Hide Away with filter included.





**Summer House.** This innovative function keeps the house at 8/10 or 8/15 °C to avoid freezing pipes during the winter. This function is beneficial for summer or weekend homes.



**Bluefin.** Panasonic has extended the life of its condensers with an original anti-rust coating.



**Large fan** provides larger air flow rate and very quiet operation at low speed.



**DC fan:** Safe and precise.



**Automatic fan operation.** Convenient microprocessor control automatically adjusts fan speed to High, Medium or Low, corresponding to room sensor and maintains comfortable air flow throughout the room.



**Self-diagnosing function.** By using electronic control valves past warnings are stored. This makes it easier to diagnose malfunctions, reducing service labour and therefore costs.



**Comfortable auto-flap control.** When the unit is first turned on, flap position is automatically adjusted in accordance with the cooling or heating operation.



**Automatic restart.** Automatic restart function for power failure. Even when power failure occurs, preset programmed operation can be reactivated once power is resumed.



**Air Sweep.** The air sweep function moves the flap up and down in the air outlet, directing air in a "sweeping" motion around the room and providing comfort in every corner.



**Built-in drain pump.** Maximum head 50cm (or 75cm for U type) from the bottom of the unit.



**Ultimate customisation.** Various pump, hydraulic, ambient options offered, plus many more. Ultimate customization for your needs and environment.



**Defrost limiting cycle** (140 – 210). Each pair of coils can be defrosted wisely while the other pair of coils are running in heating mode. This alternated defrost cycle ensures stable hot water even at low ambient conditions.



**Down to -10 °C** in cooling mode. The air conditioner works in cooling mode when the outdoor temperature of -10 °C.



**Down to -15 °C** in heating mode. The air conditioner works in heat pump mode when the outdoor temperature is as low as -15 °C.



**-20 °C operation range.** The PRO-HT Tanks work with an outdoor temperature is as low as -20 °C.



**Cooling with outdoor temperature up to 52 °C.** The ECOi EX system works in cooling mode with performance data at outdoor temperature up to 52 °C.



**R410A/R22 renewal.** The Panasonic renewal system allows good quality existing R410A or R22 pipe work to be re-used whilst installing new high efficiency R32 systems.



**R22 renewal.** The Panasonic renewal system allows good quality existing R22 pipe work to be re-used whilst installing new high efficiency R410A systems.

### High connectivity



**Renovation.** Our Aquarea Heat Pumps can be connected to an existing or new boiler for optimum comfort even at very low outdoor temperatures.



**Solar kit.** For even greater efficiency, our Aquarea Heat Pumps can be connected to photovoltaic solar panels with an optional kit.



**Advanced control.** Remote controller with full dotted 3,5" wide back light screen. Menu with 17 available languages easy to use for installer and user. Included on J and H Generation.



**Domestic integration to P-Link - CZ-CAPRA1.** Can connect RAC range to P-Link. Full control is now possible.



**Internet control.** A next generation system providing user-friendly remote control of air conditioning or heat pump units from everywhere, using a simple Android™ or iOS smartphone, tablet or PC via the internet.



**Connectivity.** The communication port can be integrated into the indoor unit and provides easy connection to, and control of, your Panasonic heat pump to your home or building management system.



**Panasonic AC Smart Cloud.** The AC Smart Cloud from Panasonic allows you to have complete control of all your installations. In a simple click, receive status updates from all your units in real-time, preventing breakdowns and optimizing costs.



**5 Years compressor warranty.** We guarantee the outdoor unit compressors in the entire range for five years.



**SG Ready:** Thanks to Aquarea HPM, Aquarea HT range is holding the SG Ready Label (Smart Grid Ready Label), given by Bundesverband Wärmepumpe (German Heat Pump Association). This Label shows the real capacity of Aquarea to be connected in an intelligent grid control. MCS Certificate number: MCS HP0086\*. Keymark: Check all our certified heat pumps on: [www.heatpumpkeymark.com](http://www.heatpumpkeymark.com).

\* Not all products certified. As the certification process is on-going and the list of certified products constantly changing, please check for latest details on the official websites.



### Quality Management System Certificate



**Certified to ISO 9001: 2008**  
Panasonic Appliances Air-Conditioning Malaysia. Sdn.Bhd.  
Cert. No.: MY-AR 1010



**Certified to ISO 9001: 2008**  
Panasonic Appliances Air-Conditioning (GuangZhou) Co., Ltd.  
Registration Number: 01209Q20645R5L

### Environmental Management System Certificate



**Certified to ISO 14001: 2004**  
Panasonic Appliances Air-Conditioning Malaysia Sdn.Bhd.  
Cert. No.: MY-ER0112



**Certified to ISO 14001: 2004**  
Panasonic Appliances Air-Conditioning (GuangZhou) Co., Ltd.  
Registration Number: 02110E10562R4L





[www.aircon.panasonic.eu](http://www.aircon.panasonic.eu)

heating & cooling solutions

Due to the ongoing innovation of our products, the specifications of this catalogue are valid barring typographic errors, and may be subject to minor modifications by the manufacturer without prior warning in order to improve the product. The total or partial reproduction of this catalogue is prohibited without the express authorisation of Panasonic Marketing Europe GmbH.

www.aircon.panasonic.eu



**Service support for installers**  
**+46 8 566 426 88**  
**aircon\_support\_se@eu.**  
**panasonic.com**



Do not add or replace refrigerant other than the specified type. Manufacturer is not responsible for the damage and deterioration in safety due to usage of the other refrigerant.  
The outdoor units in this catalogue contains fluorinated greenhouse gases with a GWP higher than 150.

# Panasonic®

To find out how Panasonic cares for you,  
log on to: [www.aircon.panasonic.eu](http://www.aircon.panasonic.eu)

Panasonic Nordic  
Branch of Panasonic Marketing Europe GmbH, Germany  
Sundbybergsvägen 1, SE-171 73 Solna, SWEDEN

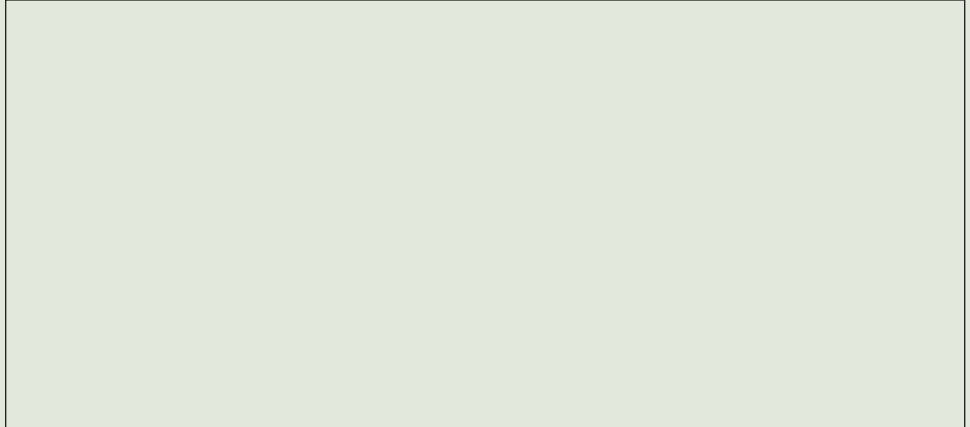

NE-EN-GCAT0820/01